



WINCOM TECH
盈达顺科技

Wincom Tech CO., LTD.

The LCD(M) Specialist

CONTACT ADDRESS : 3F, Block 13, WangJingKeng Industrial Park,
DaKan XiLi, NanShan, Shenzhen City,China.

Tel: 0086-755-83308729

Fax: 0086-755-83308659

E-mail: craig.jiang@wincomlcd.com



PART NO. : WIN159A

FOR MESSRS. : _____

CONTENTS

<i>NO.</i>	<i>ITEM</i>	<i>PAGE</i>
1.	COVER	1
2.	RECORD OF REVISION	2
3.	GENERAL SPECIFICATION	3
4.	MECHANICAL DATA	3
5.	ABSOLUTE MAXIMUM RATINGS	4
6.	ELECTRICAL CHARACTERISTICS	5
7.	OPTICAL CHARACTERISTICS	5
8.	OUTLINE DIMENSION	6~9
9.	SPECIFICATION OF QUALITY ASSURANCE	10~13

ACCEPTED BY: _____

PROPOSED BY: _____

RECORD OF REVISION

DATE	PAGE	SUMMARY

3. General specifications

3.1 General specifications

PLEASE REFER TO:

“CUSTOMER ACCEPTANCE STANDARD SPECIFICATIONS (MS-10-10000)”.

3.2 Quality Assurance and Warranty

PLEASE REFER TO:

“QUALITY ASSURANCE MANUL (MS-10-10001)”.

3.3 This individual specification is prior to general specifications

4. Mechanical data

- Display format: Segment
- LCD type: TN Positive, Transmissive
- Viewing angle: 6:00
- LCD size: 51.8 x 29.67 x 2.85mm(Max)
- View area: 45.72 x 17.78 mm
- Driving method: STATIC

5. Absolute maximum ratings

<i>I T E M</i>	<i>SYMBOL</i>	<i>MIN.</i>	<i>MAX.</i>	<i>UNIT</i>	<i>COMMENT</i>
POWER SUPPLY FOR LOGIC	V _{DD} -V _{SS}	/	10	V	Within an hour
DC COMPONENT	V _{dc}	/	0.05	V	/
OPERATING TEMP.	T _{ot}	-20	70	°C	/
STORAGE TEMP.	T _{st}	-30	80	°C	/

6. Electrical characteristics

T_a = 25°C V_{DD} = 5.0 V

<i>I T E M</i>	<i>SYMBOL</i>	<i>MIN.</i>	<i>TYP.</i>	<i>MAX.</i>	<i>UNIT</i>	<i>COMMENT</i>	
Power supply voltage for circuit	V _{OP} (-20°C)	4.0	4.2	4.4		Figure 1	
	V _{OP} (25°C)	3.8	4.0	4.2			
	V _{OP} (50°C)	3.6	3.8	4.0			
Driving frequency	FF	32	64	128	Hz	Figure 1	
Current consumption	I _s	/	/	2.3	uA/cm ²	Figure 1	
Response time	Rise	T _{ON} (25°C)	/	132	200	ms	Figure 1
		T _{ON} (70°C)	/	98	/		
	Fall	T _{OFF} (25°C)	/	148	250		
		T _{OFF} (70°C)	/	115	/		
Viewing angle	Upper and lower	∅1- ∅2	/	/	45	Deg.	Figure 2
	About	θ 1, θ2	/	/	60	Deg.	
Contrast	Cr	2	/	/		Figure 1	

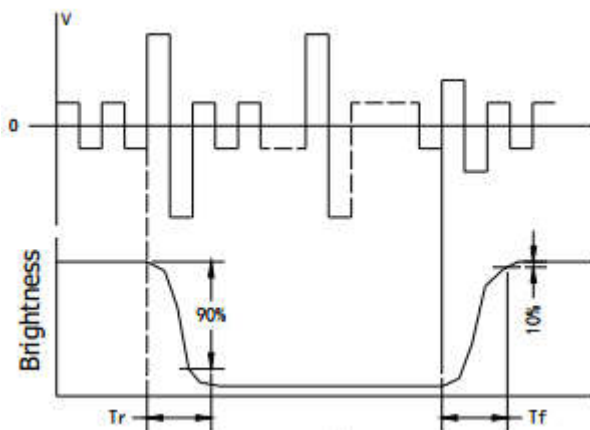

Figure 1

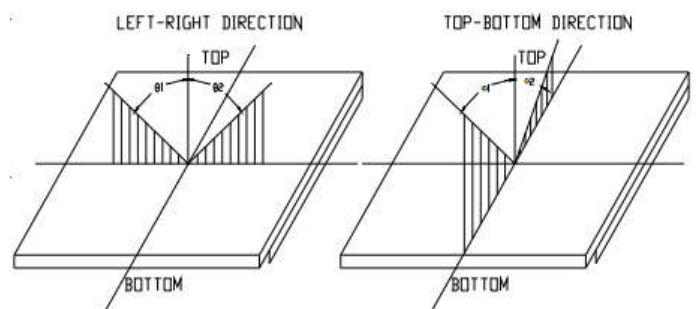
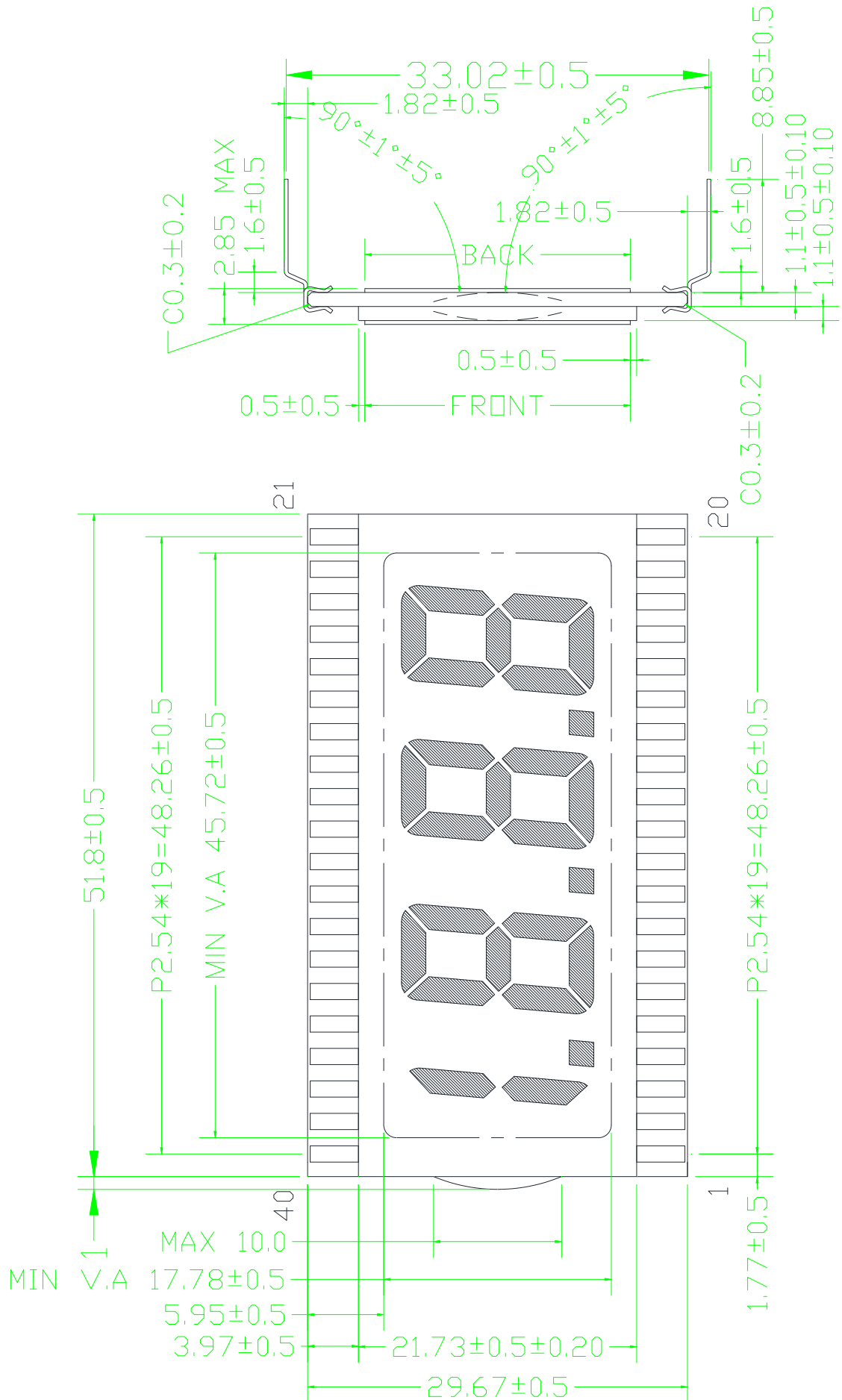
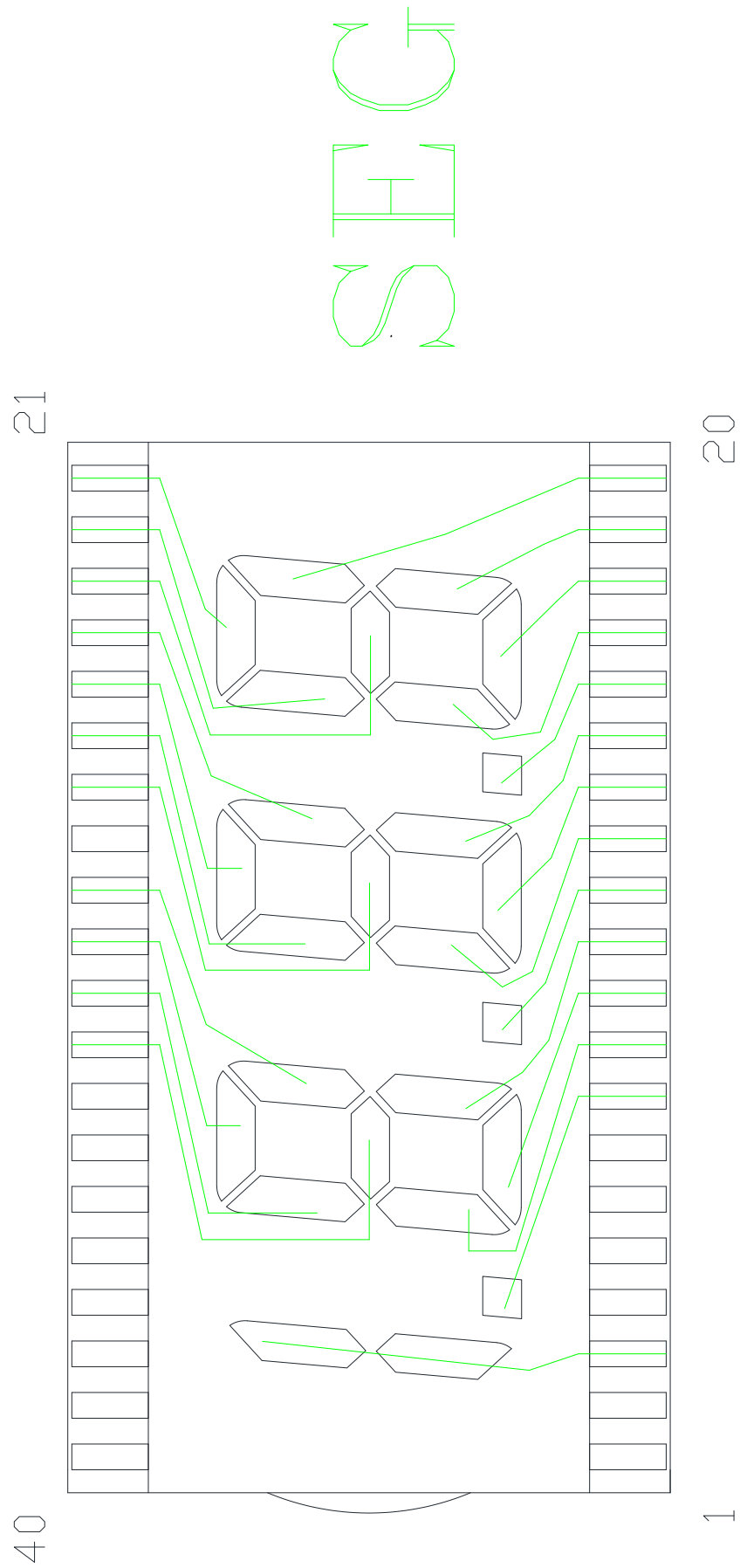

Figure 2

8. Outline dimension



8.1 Logic



COMMON

21

20

40

1

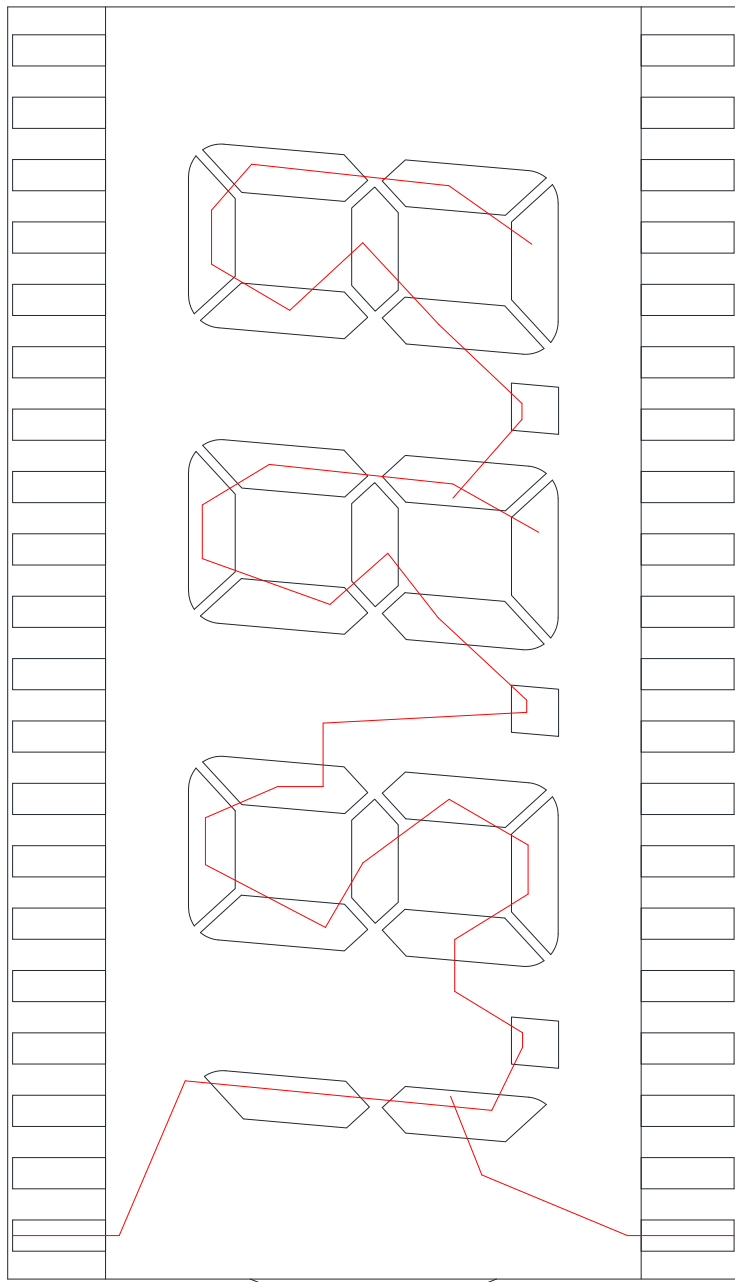

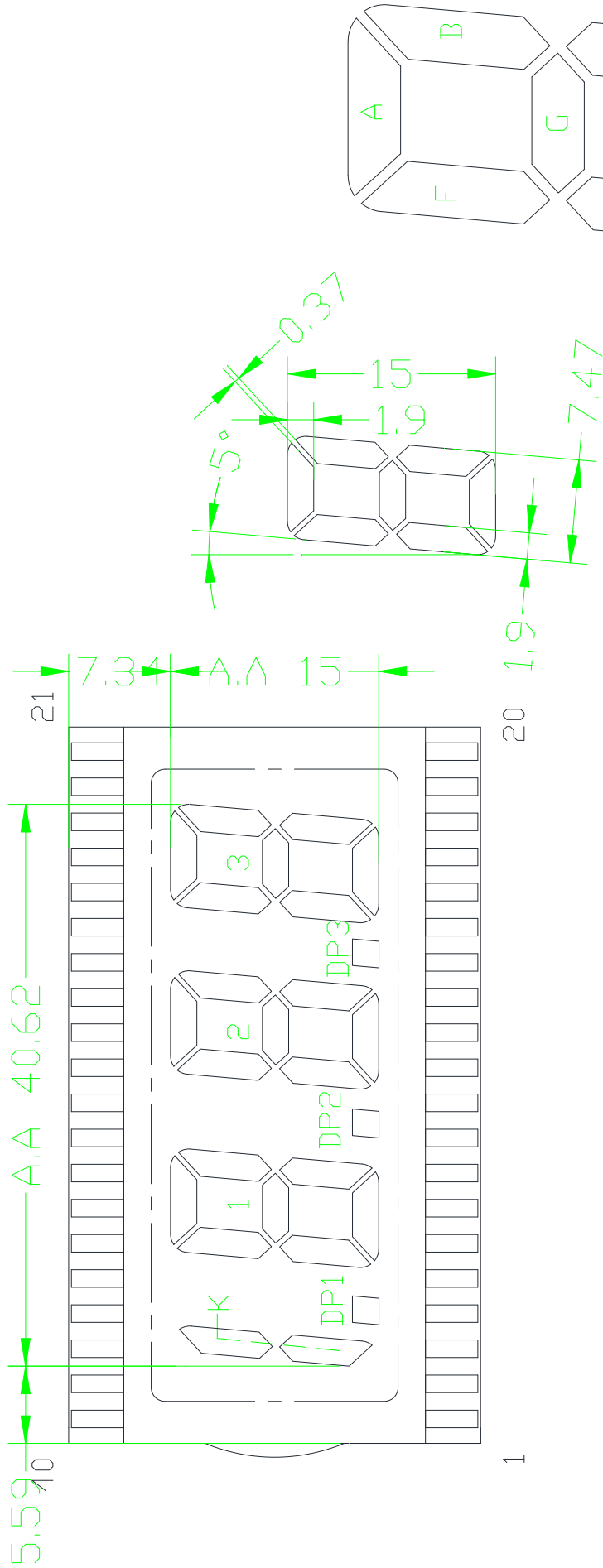

PIN	1	2	3	4	5	6	7	8	9	10	11	12	13	14	15
SEGMENT	COM	/	K	/	/	/	DP1	1E	1D	1C	DP2	2E	2D	2C	2C
PIN	16	17	18	19	20	21	22	23	24	25	26	27	28	29	30
SEGMENT	DP3	3E	3D	3C	3B	3A	3F	3G	2B	2A	2F	2G	/	1B	1A
PIN	31	32	33	34	35	36	37	38	39	40	/	/	/	/	/
SEGMENT	1F	1G	/	/	/	/	/	/	COM	40	/	/	/	/	/

9. Specification of quality assurance

AQL inspection standard

Sampling method: MIL-STD-105E, Level II, single sampling

Defect classification (**Note: * is not including**)

Classify	Item	Note	AQL	
Major	Display state	Short or open circuit	1	0.65
		LC leakage		
		Flickering		
		No display		
		Wrong viewing direction		
		Contrast defect (dim, ghost)		
	Back-light	1,8		
	Non-display	Flat cable or pin reverse	10	
		Wrong or missing component	11	
Minor	Display state	Background color deviation	2	1.0
		Black spot and dust	3	
		Line defect, Scratch	4	
		Rainbow	5	
		Chip	6	
		Pin hole	7	
	Polarizer	Protruded	12	
		Bubble and foreign material	3	
	Soldering	Poor connection	9	
	Wire	Poor connection	10	
	TAB	Position, Bonding strength	13	

Note on defect classification

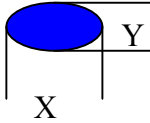
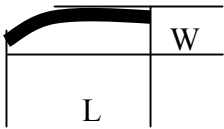
No.	Item	Criterion			
1	Short or open circuit	Not allow			
	LC leakage				
	Flickering				
	No display				
	Wrong viewing direction				
	Wrong Back-light				
2	Contrast defect	Refer to approval sample			
	Background color deviation				
3	Point defect, Black spot, dust (including Polarizer) $\phi = (X+Y)/2$		Point Size	Acceptable Qty.	
			$\phi < 0.10$	Disregard	
			$0.10 < \phi \leq 0.20$	3	
			$0.20 < \phi \leq 0.25$	2	
			$0.25 < \phi \leq 0.30$	1	
			$\phi > 0.30$	0	
Unit:mm					
4	Line defect, Scratch		Line		Acceptable Qty.
			L	W	
			---	$0.015 \geq W$	2
			$3.0 \geq L$	$0.03 \geq W$	
			$2.0 \geq L$	$.05 \geq W$	1
			$1.0 \geq L$	$0.1 > W$	
---	$0.05 < W$	Applied as point defect			
5	Rainbow	Not more than two color changes across the viewing area.			

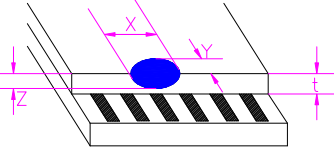
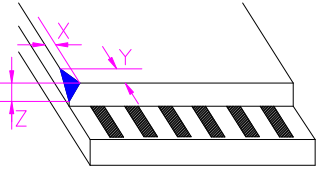
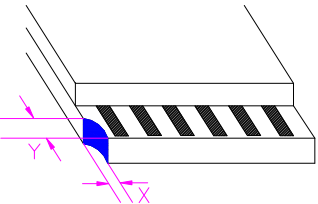
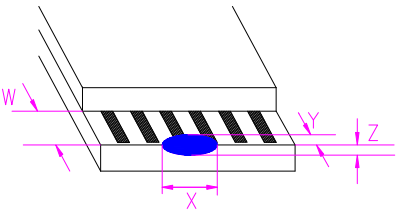
NO.	Item	Criterion																																							
6	<p>Chip</p> <p>Remark:</p> <p>X: Length direction</p> <p>Y: Short direction</p> <p>Z: Thickness direction</p> <p>t: Glass thickness</p> <p>W: Terminal Width</p>	 <table border="1" data-bbox="1029 380 1492 526"> <thead> <tr> <th colspan="3">Acceptable criterion</th> </tr> <tr> <th>X</th> <th>Y</th> <th>Z</th> </tr> </thead> <tbody> <tr> <td>≤ 2</td> <td>0.5mm</td> <td>$\leq t/2$</td> </tr> </tbody> </table>  <table border="1" data-bbox="1029 728 1492 884"> <thead> <tr> <th colspan="3">Acceptable criterion</th> </tr> <tr> <th>X</th> <th>Y</th> <th>Z</th> </tr> </thead> <tbody> <tr> <td>≤ 2</td> <td>0.5mm</td> <td>$\leq t$</td> </tr> </tbody> </table>  <table border="1" data-bbox="1029 1019 1492 1254"> <thead> <tr> <th colspan="3">Acceptable criterion</th> </tr> <tr> <th>X</th> <th>Y</th> <th>Z</th> </tr> </thead> <tbody> <tr> <td>≤ 3</td> <td>≤ 2</td> <td>$\leq t$</td> </tr> <tr> <td colspan="2">shall not reach to ITO</td> <td></td> </tr> </tbody> </table>  <table border="1" data-bbox="1029 1680 1492 1825"> <thead> <tr> <th colspan="3">Acceptable criterion</th> </tr> <tr> <th>X</th> <th>Y</th> <th>Z</th> </tr> </thead> <tbody> <tr> <td>Disregard</td> <td>≤ 0.2</td> <td>$\leq t$</td> </tr> </tbody> </table>	Acceptable criterion			X	Y	Z	≤ 2	0.5mm	$\leq t/2$	Acceptable criterion			X	Y	Z	≤ 2	0.5mm	$\leq t$	Acceptable criterion			X	Y	Z	≤ 3	≤ 2	$\leq t$	shall not reach to ITO			Acceptable criterion			X	Y	Z	Disregard	≤ 0.2	$\leq t$
Acceptable criterion																																									
X	Y	Z																																							
≤ 2	0.5mm	$\leq t/2$																																							
Acceptable criterion																																									
X	Y	Z																																							
≤ 2	0.5mm	$\leq t$																																							
Acceptable criterion																																									
X	Y	Z																																							
≤ 3	≤ 2	$\leq t$																																							
shall not reach to ITO																																									
Acceptable criterion																																									
X	Y	Z																																							
Disregard	≤ 0.2	$\leq t$																																							

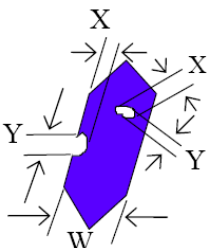
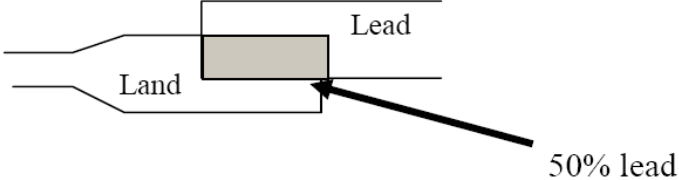
No.	Item	Criterion								
7	Segment pattern $W = \text{Segment width}$ $\phi = (X+Y)/2$	(1) Pin hole $\phi < 0.10\text{mm}$ is acceptable.  <table border="1" data-bbox="1029 309 1468 481"> <thead> <tr> <th>Point Size</th> <th>Acceptable Qty</th> </tr> </thead> <tbody> <tr> <td>$\phi \leq 1/4W$</td> <td>Disregard</td> </tr> <tr> <td>$1/4W < \phi \leq 1/2W$</td> <td>1</td> </tr> <tr> <td>$\phi > 1/2W$</td> <td>0</td> </tr> </tbody> </table> <p style="text-align: right;">Unit: mm</p>	Point Size	Acceptable Qty	$\phi \leq 1/4W$	Disregard	$1/4W < \phi \leq 1/2W$	1	$\phi > 1/2W$	0
Point Size	Acceptable Qty									
$\phi \leq 1/4W$	Disregard									
$1/4W < \phi \leq 1/2W$	1									
$\phi > 1/2W$	0									
8	Back-light	(1) The color of backlight should correspond its specification. (2) Not allow flickering								
9	Soldering	(1) Not allow heavy dirty and solder ball on PCB. (The size of dirty refer to point and dust defect) (2) Over 50% of lead should be soldered on Land. 								
10	Wire	(1) Copper wire should not be rusted (2) Not allow crack on copper wire connection. (3) Not allow reversing the position of the flat cable. (4) Not allow exposed copper wire inside the flat cable.								
11*	PCB	(1) Not allow screw rust or damage. (2) Not allow missing or wrong putting of component.								

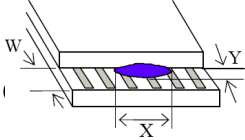
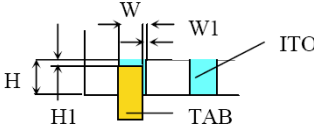
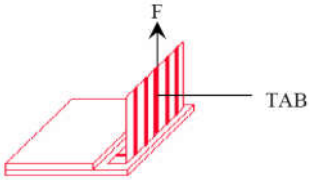
NO.	Item	Criterion
12	Protruded W: Terminal Width	 <p style="text-align: right;">Acceptable</p> <p style="text-align: right;">$Y \leq 0.4$</p>
13	TAB	<p>1. Position</p>  <p style="text-align: right;">$W1 \leq 1/3W$ $H1 \leq 1/3H$</p> <p>2 TAB bonding strength test</p>  <p>$P (=F/TAB \text{ bonding width}) \geq 650\text{gf/cm}$, (speed rate: 1mm/min) 5pcs per SOA (shipment)</p>
14	Total no. of acceptable Defect	<p>A. Zone Maximum 2 minor non-conformities per one unit. Defect distance: each point to be separated over 10mm</p> <p>B. Zone It is acceptable when it is no trouble for quality and assembly in customer's end product.</p>