

## 1. QUARTZ CRYSTAL UNIT SPECIFICATION

Parameter	Specification
1.1 Frequency:	32.768KHz
1.2 Holder type:	DT38
1.3 Frequency tolerance:	±10ppm at 25°C
1.4 Equivalent resistance:	30Kohms Max
1.5 Operating temperature range:	-40°C To +85°C
1.6 Storage temperature range:	-40°C To +85°C
1.7 Temperature Coefficient:	-0.04×10 <sup>-6</sup> / °C <sup>2</sup> max
1.8 Turn-over temperature::	+25°C±5°C
1.9 Loading capacitance (CL):	12.5pF
1.10 Drive level:	1.0uW max
1.11 Shunt Capacitance:	2.0pF max
1.12 Motional Capacitance:	
1.13 Insulation resistance:	More than 500M ohms
1.14 Aging:	±3 ppm/Year Max (+25°C First Year)
1.15 Dimensions and marking:	Refer to page.3
1.16 RoHS Compliant:	Yes

### Standard atmospheric conditions

Unless otherwise specified, the standard range of atmospheric conditions for making measurement and tests are as follow:

Ambient temperature : 25±3 °C

Relative humidity : 40%~70%

## 2. DIMENSIONS (Unit: mm)

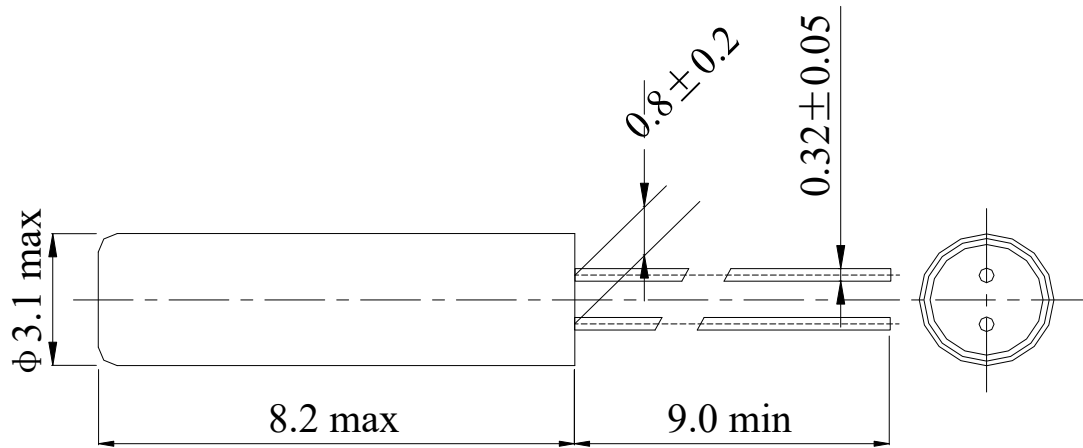

### Note:

焊接部位仅局限于引脚离开玻璃纤部位 1.0mm 以上的部位，并且请不要对外壳进行焊接。

如果利用高温或长时间对引脚部位进行加热，会导致晶振特性的恶化以及晶振的破损。因此，请注意对引脚部位的加热温度要控制在  $300^{\circ}\text{C}$  以下，且加热时间要控制在 5 秒以内。

The soldering position has to be at the lead wire more than 1.0mm away from the glass seal.

When mounting or removing a quartz crystal unit, heat the lead part at  $300^{\circ}\text{C}$  or lower for 5 seconds or less .  
A long period of time of heating may result in deterioration of the characteristics and may break the crystal unit. Be sure not to heat the case by flow soldering and so on.

**3. Mechanical Endurance: Provided that measurement shall be carried out after letting it alone in the room temperature for 1 hour.**

Item	Conditions	Specifications
Shock (Destructive)	Resonator shall be tested after 3 times random drops from the height of 30 cm onto hard wooden board of thickness more than 30 mm.	No visible damage, measured Values shall meet Table 1.
Vibration (Destructive)	Subject resonator to following vibration Frequency: 10-55Hz Amplitude: 1.5mm Cycle time: 1~2min(10-55-10Hz) Duration: 3 mutually perpendicular Planes in each 3 minutes Direction: X, Y, Z	No visible damage, and measured Values shall meet Table 1.
Terminal Strength (Destructive)	Pulling: body of resonator shall be fixed, and 0.5kg of tension weight shall be supplied gradually to axial direction of lead terminals for 30 seconds	The lead shall not be broken, measured Values shall meet Table 1.
	Bending: body of resonator shall be fixed, And 90° bending at a distance of 2.5±0.5 mm from crystal main body shall be given being supplied 250g tension weight. after that, lead terminals shall be straightened gradually. Then, the same bending and straightening shall be supplied to the opposite direction in the same axial.	
Solder Heating (Destructive)	Each lead terminals shall be dipped into the solder melted tank at 300±10°C for 3±0.5 resonator, and at 260±10°C for 10 ± 1 seconds by the same way.	No visible damage, and measured Values shall meet Table 1.
Solder ability (Destructive)	Dip the lead in liquid solder for 2± 0.5 seconds, at 230±5°C and 2.0mm from the root, after this dipping, 90% min. of dipped parts shall be covered with solder.	No visible damage, and measured Values shall meet Table 1.
Leakage (non-destructive)	The resonator is to be soaked in the alcohol and enforced with the pressure of 25N/cm <sup>2</sup> for 5 minutes Next, the resonator shall be tested after being taken out and dried with a dryer.	The Ir between the wire and the shell must be more than 500MΩ.

**4. Environmental Endurance: Provided that measurement shall be carried out after letting it alone in the room temperature for 2 hours.**

	Item	Conditions	Specifications
4.1	Humidity	Should be satisfied after letting it alone at $+60^{\circ}\text{C}\pm 2^{\circ}\text{C}$ in humidity of $93\% \pm 2\%$ for 24 hours.	No visible damage, measured Values shall meet Table1.
4.2	Storage in Low Temperature	Should be satisfied after letting it alone at $-30^{\circ}\text{C}\pm 2^{\circ}\text{C}$ for 72 hours.	No visible damage, measured Values shall meet Table1
4.3	Storage in High Temperature	Should be satisfied after letting it alone at $+70^{\circ}\text{C}\pm 2^{\circ}\text{C}$ for 72 hours.	No visible damage, measured Values shall meet Table1
4.4	Temperature Cycle	Should be satisfied after supplying the following temperature cycle ( 5 cycles). (Refer to Fig-4). Temperature shift from low to high, high to low shall be done in $1^{\circ}\text{C} /\text{min}$ .	No visible damage, measured Values shall meet Table1

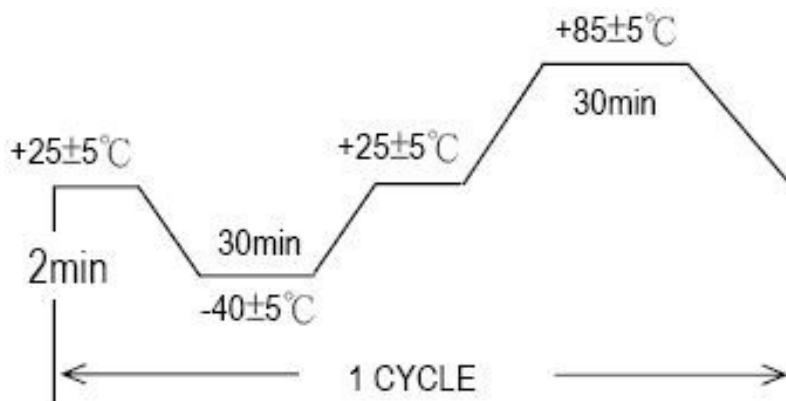

Fig-4

Table 1

Test Item	Specification	Note
Frequency change ( $\Delta f/f_0$ )	$\pm 5\text{ppm}$	Reference to the initial value
C.I. ( $\Delta R$ )	15%	Reference to the initial value