

深圳市炬烜科技有限公司
CHIP SUN TECHNOLOGY CO., LTD

**APPROVAL
SHEET**



(Seam Type)

CUSTOMER: _____
DESCRIPTION: SMD3225 12.288MHz Quartz Crystal Resonator
MANUFACTURER PART NO.: FTX12.288M18SM3S-20/30BEW
CUSTOMER PART NO: _____
USED IN MODEL: _____
REVISION A1

承 认 APPROVAL		
工程部 TECHNOLOGY DEPT.	品质部 QUALITY DEPT.	采购部 PURCHASING DEPT.

Date: March 22, 2023



深圳市炬烜科技有限公司

CHIP SUN TECHNOLOGY CO., LTD

地址 ADD: 深圳市龙华新区大浪腾龙路淘金地电子商务孵化基地 B 座 206
Rm. Rm 206, Tower B, Taojindi Building, Tenglong Road, Dalang Street,
Longhua New District, Shenzhen, China

电话 TEL: 86-755-83458796 传真 FAX: 86-755-83459818

网址 WEB ADD: <http://www.chinachipsun.com>

E-MAIL: sales01@chinachipsun.com

<u>Rev</u>	<u>Revise page</u>	<u>Revise contents</u>	<u>Date</u>	<u>Ref.No.</u>	<u>Reviser</u>
A1	ALL	Initial released		N/A	DavidJiang

CHIP SUN TECHNOLOGY CO., LTD		
DESCRIPTION	SMD3225 12.288MHz ±20ppm 18pF	Page:
DATE	2023-03-22	2 / 12

1. QUARTZ CRYSTAL UNIT SPECIFICATION

Parameter	Sign	Specification
1.1 Nominal Frequency :	F0	12.288MHz
1.2 Holder type :	-	FTX321S (SMD3225 SEAM TYPE)
1.3 Mode of oscillation :	-	Fundamental
1.4 Frequency tolerance :	FL	±20ppm at 25°C±3°C
1.5 Equivalent resistance :	RR	80ohms max.
1.6 Operating temperature range :	T _{OPR}	-20°C To +70°C
1.7 Storage temperature range :	T _{STG}	-55°C To +125°C
1.8 Frequency Stability :	TC	±20ppm at -20°C To +70°C
1.9 Loading capacitance :	CL	18pF
1.10 Drive level :	DL	10 uW Typical, 100uW max.
1.11 Shunt Capacitance :	C0	2.0pF max.
1.12 Insulation resistance :	IR	More than 500MΩ at DC 100V
1.13 Circuit:	-	Measured in HP/E5100A,S&A 250B
1.14 Aging :	Fa	±2ppm max. (+25°C 1 st Year)
1.15 Dimensions and marking :		Refer to page.3
1.16 Emboss carrier tape & reel :		Refer to page.5 and page.6
1.17 Note :		

Standard atmospheric conditions

Unless otherwise specified, the standard range of atmospheric conditions for making measurement and tests are as follow:

Ambient temperature : 25±3°C

Relative humidity : 40%~70%

CHIP SUN TECHNOLOGY CO., LTD		
DESCRIPTION	SMD3225 12.288MHz ±20ppm 18pF	Page:
DATE	2023-03-22	3 / 12

2. FTX321S MARKING & DIMENSIONS

(UNIT: mm)

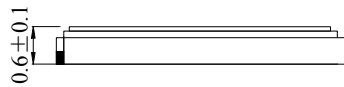
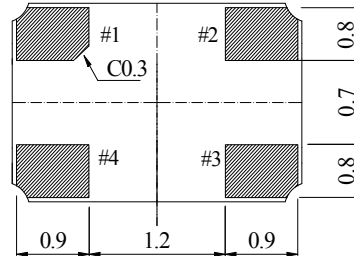
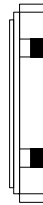
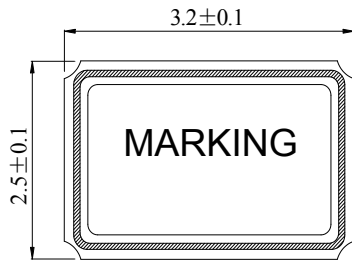

Marking #2, #4 is connected with metal cap of top.

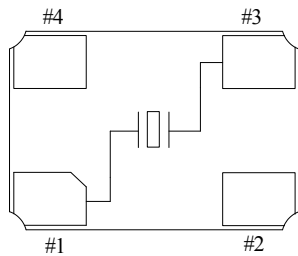

<TOP VIEW>

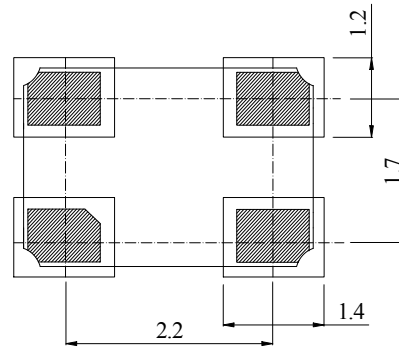

Recommended Solder Pad Layout:

*Marking should be printed as following:

Logo, Nominal Frequency

*Manufacturing Logo: FT

*Nominal frequency = 3 number after decimal point MAX.

(ex. 12.000 MHz → 12.000)

Marking: Laser marking

CHIP SUN TECHNOLOGY CO., LTD

DESCRIPTION	SMD3225 12.288MHz ±20ppm 18pF	Page:
DATE	2023-03-22	4 / 12

3. INSIDE STRUCTURE

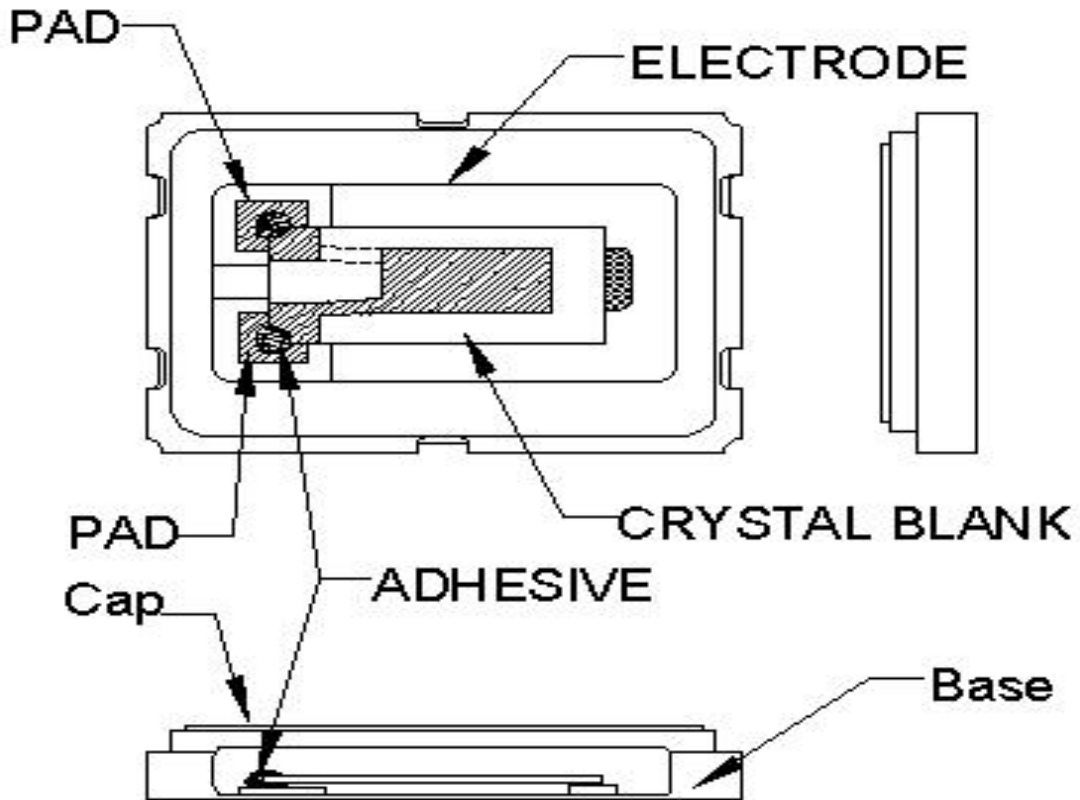

Reference drawing

Base:	Alumina Ceramic (Al_2O_3) Metallized Pad: W Ni Plating Au Plating
Cap:	Fe-Ni
(3) Crystal Enclosure Seal:	Seal Seam
(4) Crystal Blank	Rectangular At-Cut Quartz Crystal Blank
(5) Adhesive	Silver Conductive Polyimide Resin
(6) Electrode	Ag
(7) PAD	Alumina Ceramic (W. Ni. Au)

CHIP SUN TECHNOLOGY CO., LTD

DESCRIPTION	SMD3225 12.288MHz ± 20 ppm 18pF	Page:
DATE	2023-03-22	5 / 12

4. FTX321S EMBOSS CARRIER TAPE & REEL

a.) Dimensions of Carrier Tape

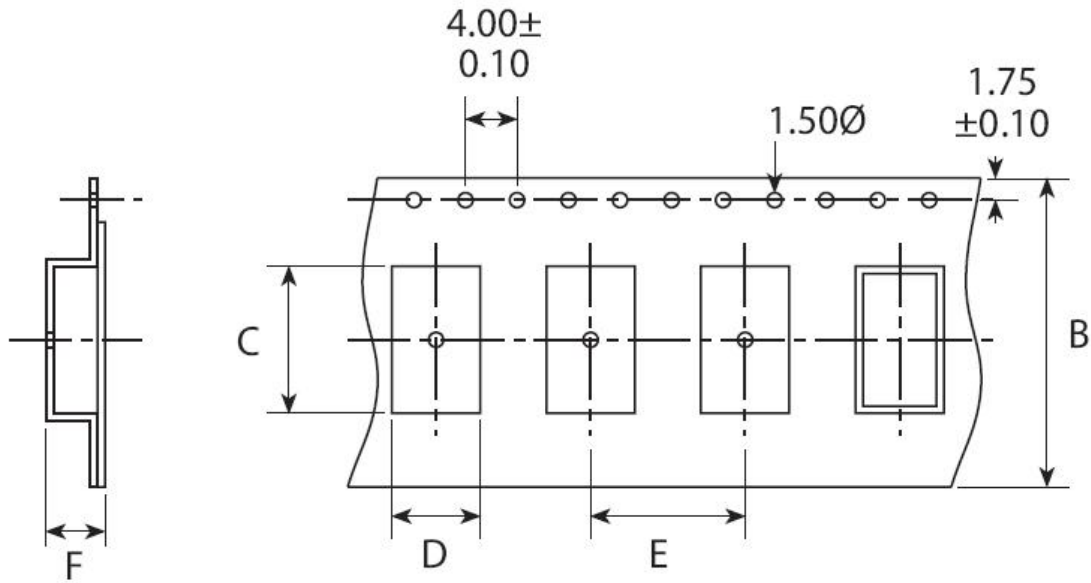

	A	B	C	D	E	F	G
SMD3225	178 ± 2.0	8.0 ± 0.3	3.5 ± 0.1	2.8 ± 0.1	4.0 ± 0.1	1.4 ± 0.1	60.5 ± 1.0

(UNIT: mm)

b.) Dimensions of Reel

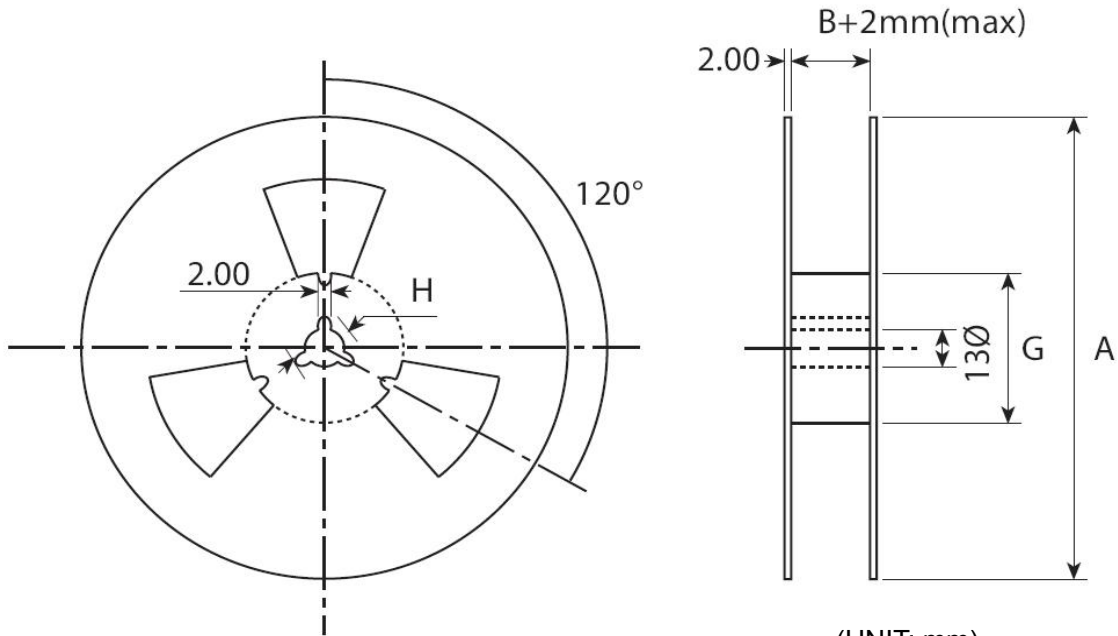

(UNIT: mm)

CHIP SUN TECHNOLOGY CO., LTD

DESCRIPTION	SMD3225 12.288MHz $\pm 20\text{ppm}$ 18pF	Page:
DATE	2023-03-22	6 / 12

c.) Storage condition

Temperature: +40deg.C Max.

Relative Humidity: 80% Max.

d.) Standard packing quantity

3,000PCS / REEL

e.) Material of the tape

Tape	Material
Carrier tape	A – PET
Top tape	Polyester

f.) Label contents

.The type of product

.Our specification No.

.Your Part No.

.Lot No.

.Nominal Frequency

.Quantity

.Our Company Name

Sticks label for every reel.

PART NUMBER	
PO NO	
PR. NO:	
HOLDER TYPE	
FREQUENCY	
REMAKS	
QUANTITY	
CHIP SUN TECHNOLOGY CO., LTD	

CHIP SUN TECHNOLOGY CO., LTD

DESCRIPTION	SMD3225 12.288MHz \pm 20ppm 18pF	Page:
DATE	2023-03-22	7 / 12

g.) Taping dimension

Leader	Cover-tape	The length of cover-tape in the leader is more than 400 mm including empty embossed area.
	Carrier-tape	After all products were packaged, must remain more than twenty pieces or 400 mm empty area, which should be sealed by cover-tape.
Terminal	Cover-tape	The tip of cover-tape shall be fixed temporary by paper tape and roll around the core of reel one round.
	Carrier-tape	The empty embossed area which are sealed by top cover-tape must remain more the 40 mm.

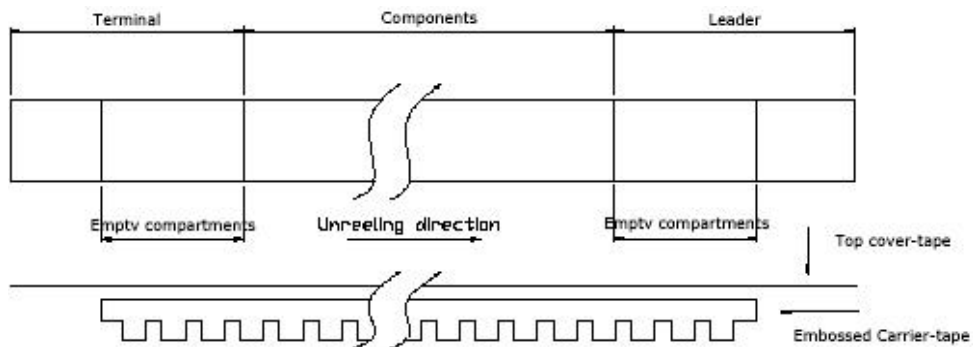

h.) Joint of tape

The carrier-tape and top cover-tape should not be jointed.

i.) Release strength of cover tape

It has to between 0.1N to 0.7N under following condition.

Pulling direction 165° to 180°

Speed 300mm/min.

Otherwise unless specified.

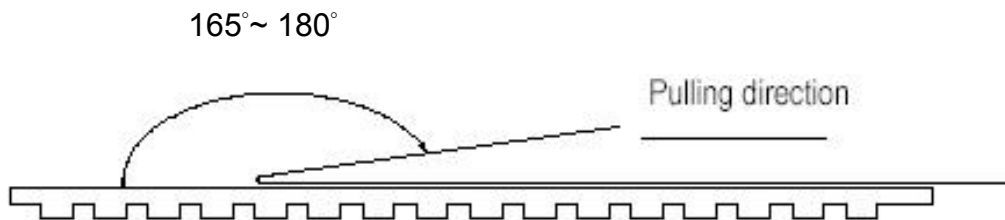

Other standards shall be based on JIS C 0806-1990.

CHIP SUN TECHNOLOGY CO., LTD		
DESCRIPTION	SMD3225 12.288MHz ±20ppm 18pF	Page:
DATE	2023-03-22	8 / 12

5. Mechanical Endurance: Provided that measurement shall be carried out after letting it alone in the room temperature for 1 hour.

	Item	Conditions	Specifications
5.1	Drop	Fall freely from 100 cm of height 3 times on a firm wood	MIL-STD-202F-203B
5.2	Mechanical Shock	Device are shocked to half sine wave (1000 G) three mutually perpendicular axes each 3 times.	MIL-STD-202F
5.3	Vibration	(1)Vibration Frequency: 10~55Hz (2)Cycle: 1 to 2 Min. (3)Full Cycle: 1.5mm P-P. (4)Direction: X.Y.Z (5)Time: 2 Hours / Each Direction	MIL-STD-883E
5.4	Substrate Bending	Mount the specimen on substrate. Apply the following pressure Direction: see Fig -1 Speed: 0.5 mm/sec Hours: 5 ± 1 sec Amount of substrate: 3 mm Max.	Without mechanical damage such as breaks. Without electrode peeling. Electrical characteristics shall be satisfied.
5.5	Adhesion	Mount the specimen on substrate. Apply the following pressure Direction: see Fig -2 Weight: 10N Hours: 10 ± 1 sec	
5.6	Body strength	Mount the specimen on substrate. Apply the following pressure Direction: see Fig -3 Weight: 10N Hours: 10 ± 1 sec	
5.7	Seal	Fine Leak: 4.5kgf/cm ² 2hours 1×10 ⁻⁹ Pa.m ³ /sec Gross Leak: 4.5kgf/cm ² 2hours 1.5×10 ⁻⁵ Pa.m ³ /sec	

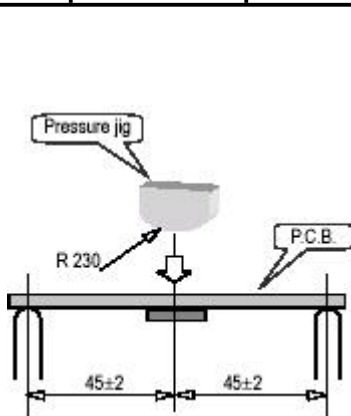

Fig-1

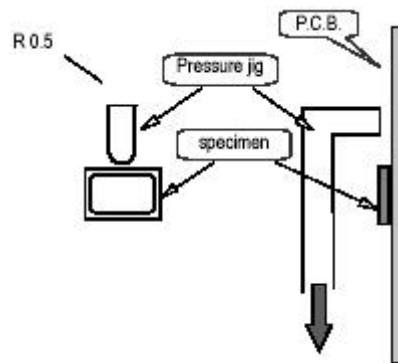

Fig-2

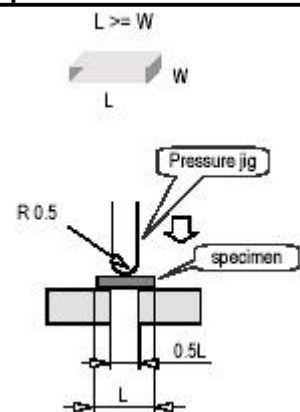
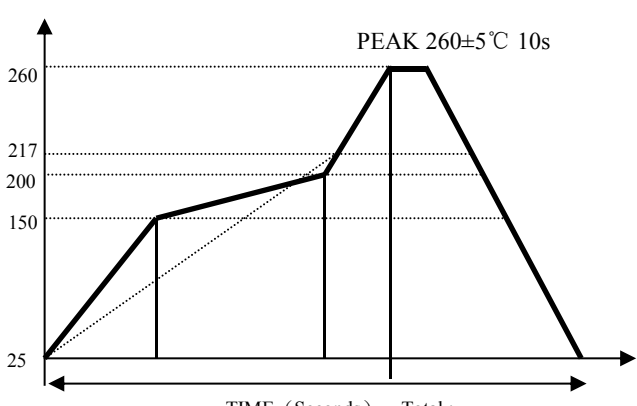

Fig-3

CHIP SUN TECHNOLOGY CO., LTD

DESCRIPTION	SMD3225 12.288MHz ±20ppm 18pF	Page:
DATE	2023-03-22	9 / 12

5.8	Solder ability	Pre-heat temperature : $+150\pm 10^{\circ}\text{C}$ Pre-heat time : 60~120s When the temperature of the specimen is reached at $+215\pm 3^{\circ}\text{C}$, it shall be left for $30\pm 1\text{sec}$. Peak temperature $240\pm 5^{\circ}\text{C}$ Material: Pb-free (Sn-3.0Ag-0.5Cu) Flux : Rosin resin methyl alcohol solvent (1:4) The electrodes should be covered by a new solder at least 90% of immersed area.	MIL-STD-883E 2003
-----	----------------	--	-------------------

5.9	Resistance to Soldering Heat	<p>Run in Reflow Reflow soldering shall be allowed Only two(2) time.</p> <p style="text-align: center;">Available for Lead Free Soldering</p>  <p style="text-align: center;">TIME (Seconds) Total :</p> <table border="1" data-bbox="446 1299 1037 1456"> <tr> <td>(1)</td> <td>Preheat</td> <td>160~180 deg.C</td> <td>120sec.</td> </tr> <tr> <td>(2)</td> <td>Primary heat</td> <td>220 deg.C</td> <td>60sec.</td> </tr> <tr> <td>(3)</td> <td>Peak</td> <td>260 deg.C</td> <td>10sec. Max.</td> </tr> </table>	(1)	Preheat	160~180 deg.C	120sec.	(2)	Primary heat	220 deg.C	60sec.	(3)	Peak	260 deg.C	10sec. Max.	MIL-STD-202F
(1)	Preheat	160~180 deg.C	120sec.												
(2)	Primary heat	220 deg.C	60sec.												
(3)	Peak	260 deg.C	10sec. Max.												

CHIP SUN TECHNOLOGY CO., LTD		
DESCRIPTION	SMD3225 12.288MHz $\pm 20\text{ppm}$ 18pF	Page:
DATE	2023-03-22	10 / 12

6. Environmental Endurance: Provided that measurement shall be carried out after letting it alone in the room temperature for 1 hour.

	Item	Conditions	Specifications
6.1	Humidity	+60°C±2°C, RH 80~85%, Duration of 500 hours. The units are then allowed to stand for approx 2 hours in room temperature before checking	MIL-STD-202F
6.2	Storage in Low Temperature	Temperature: -40±2°C , Duration of 500 hours. The units are then allowed to stand at room temperature for approx 2 hours before checking.	MIL-STD-883E
6.3	Storage in High Temperature	Temperature: +85°C±2°C , Duration of 500 hours. The units are then allowed to stand at room temperature for approx 2 hours before checking.	MIL-STD-883E
6.4	Thermal Shock	Temperature 1: -55°C±5°C Temperature 2: 125°C±5°C Temperature change between T1 and T2 at soonest Run 100 cycles, maintain T1 and T2 30minutes each in one cycle (Refer to Fig-4)	MIL-STD-883E

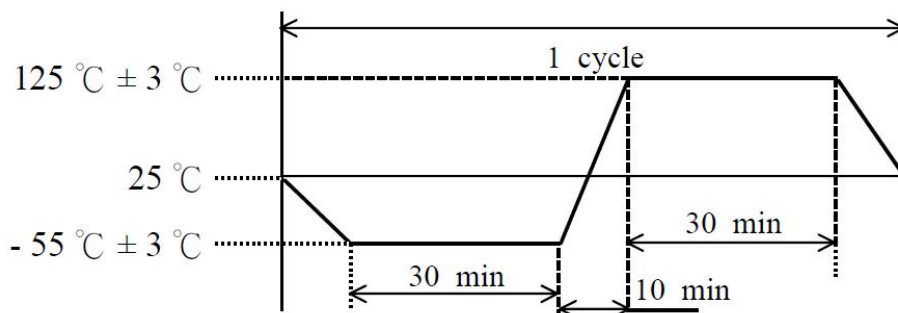

CHIP SUN TECHNOLOGY CO., LTD		
DESCRIPTION	SMD3225 12.288MHz ±20ppm 18pF	Page:
DATE	2023-03-22	11 / 12

7. Recommended Solder Reflow Profile

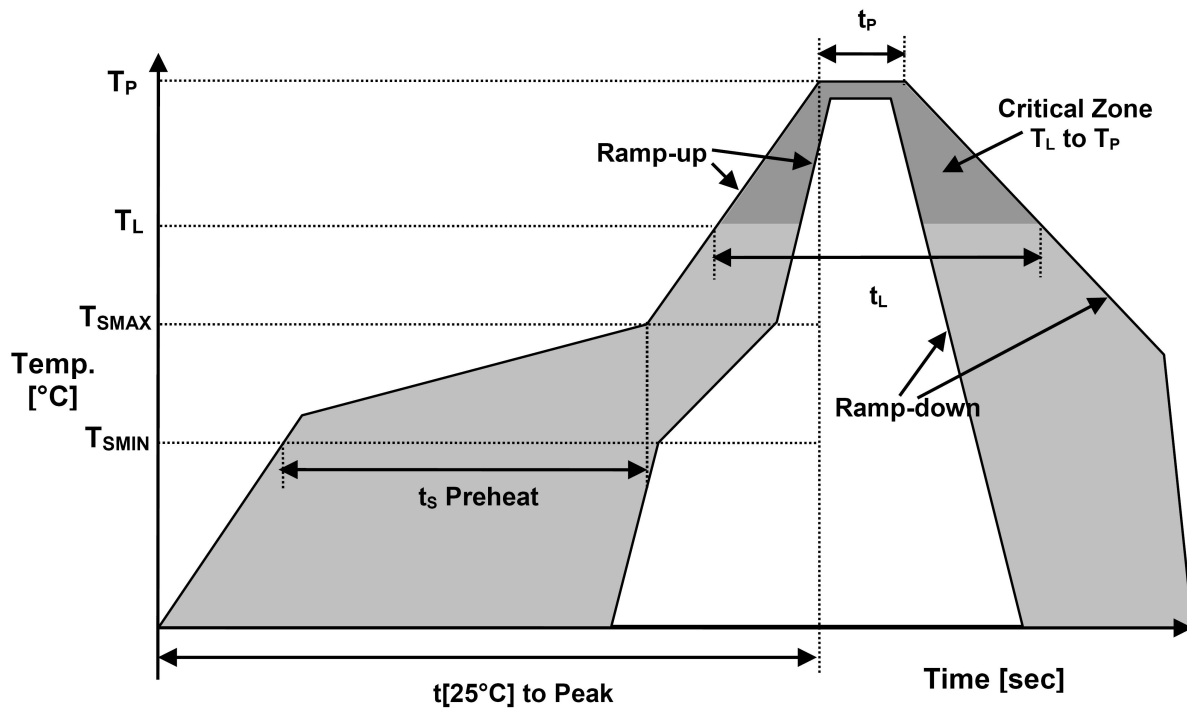

Temperature Min Preheat	T_{SMIN}	150°C
Temperature Max Preheat	T_{SMAX}	175°C
Time (T_{SMIN} to T_{SMAX})	t_s	60-180 sec.
Temperature	T_L	217°C
Peak Temperature	T_P	260°C
Ramp-up rate	R_{UP}	3°C/sec max.
Ramp-down rate	R_{DOWN}	6°C/sec max.
Time within 5°C of Peak Temperature	t_p	10 sec max.
Time $t_{[25^\circ\text{C}]}$ to Peak Temperature	$t_{[25^\circ\text{C}]}$ to Peak	480 sec max.
Time	t_L	60-150 sec.

CHIP SUN TECHNOLOGY CO., LTD

DESCRIPTION	SMD3225 12.288MHz ± 20 ppm 18pF	Page:
DATE	2023-03-22	12 / 12