

500mA Adjustable High-Speed Low Power LDO

Features

- Programmable Output: Minimum can go to 0.8V
- Low Power Consumption: 50μA (Typ.)
- Low Voltage Drops: 0.15V@50mA
- Standby Mode: 0.1uA
- Low Temperature Coefficient
- Active Discharge Function
- High Ripple Rejection: 70dB@100Hz (Typ.)
- High Input Voltage (up to 8V)
- Output Voltage Accuracy: Tolerance ±2%
- Build-in Enable / Output Current Limit
- SOT23-5/DFN1×1-4/DFN2×2-6 Package

Applications

- Cellular Handsets
- Battery-Powered Equipment
- Wi-Fi Router
- Hand-Held Instruments
- Portable Information Application
- Adjustable power supply

General Description

The RY6050-ADJ series are highly precise, low noise, positive voltage LDO regulators manufactured using CMOS processes. The series achieves high ripple rejection and low dropout and consists of a standard voltage source, an error correction, current limiter and a phase compensation circuit plus a driver transistor. External output feedback, customers can easily get the required voltage. In order to make the load current does not exceed the current capacity of the output transistor, built-in over-current protection, over temperature protection and short circuit protection. The internal op amp with advanced structure, the output capacitor can be omitted. The RY6050-ADJ series are available in SOT23-5, DFN4-1×1, DFN6-2×2 package.

Typical Application Circuit

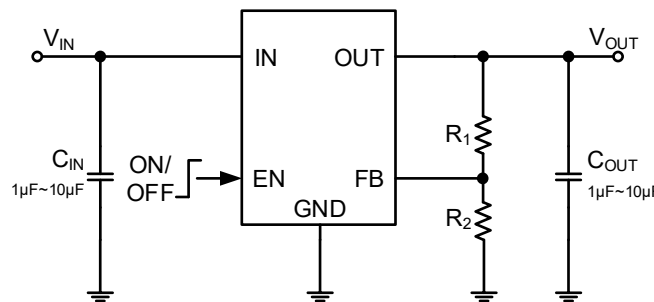

Typical Application Circuit with FB

$$V_{OUT} = 0.8 \times (1 + R1/R2)$$

500mA Adjustable High-Speed Low Power LDO

Pin Description

Pin Configuration

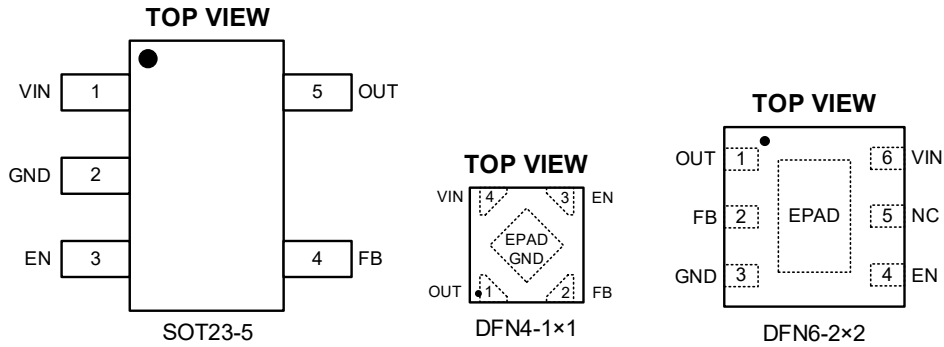

Pin Description

SOT23-5 Pin No.	DFN1×1 Pin No.	DFN2×2 Pin No.	Pin Name	Function
1	4	6	VIN	Input voltage pin for the regulator.
2	-	3	GND	Ground pin.
3	3	4	EN	Enable Control (Active high), Driving EN over 0.9 V turns on the regulator. Driving EN below 0.4 V puts the regulator into shutdown mode.
-	-	5	NC	Not Connected.
4	2	2	FB	FB pin for adjustable output option
5	1	1	OUT	Output voltage pin for the regulator.
-	EPAD	EPAD	EPAD	Exposed pad should be connected directly to the GND pin.

Mark Rule

Model	Marking	Device Code	<u>Y</u>	<u>LL</u>
RY6050-ADJM5R	NBYLL	NB	Year Code	Lot Number Code
RY6050-ADJD4R	NEYLL	NE	Year Code	Lot Number Code
RY6050-ADJD6R	NHYLL	NH	Year Code	Lot Number Code

500mA Adjustable High-Speed Low Power LDO

Order Information ⁽¹⁾
RY6050-ADJ^{①②③④}

Designator	Symbol	Description		
①②	Integer	Output Voltage		
③	M5	SOT23-5		
	D4	DFN4-1×1		
	D6	DFN6-2×2		
④	R	RoHS / Pb Free		
	G	Halogen Free		
Part No.	Model	Description	Package	T/R Qty
70605021	RY6050-ADJM5R	RY6050-ADJM5R HPSRR LDO, ADJ, 500mA, SOT23-5	SOT23-5	3000PCS
70606022	RY6050-ADJD4R	RY6050-ADJD4R HPSRR LDO, ADJ, 500mA, DFN4-1×1	DFN4-1×1	10000PCS
70606023	RY6050-ADJD6R	RY6050-ADJD6R HPSRR LDO, ADJ, 500mA, DFN6-2×2	DFN6-2×2	5000PCS

Note (1): All RYCHIP parts are Pb-Free and adhere to the RoHS directive.

500mA Adjustable High-Speed Low Power LDO

Functional Block Diagram

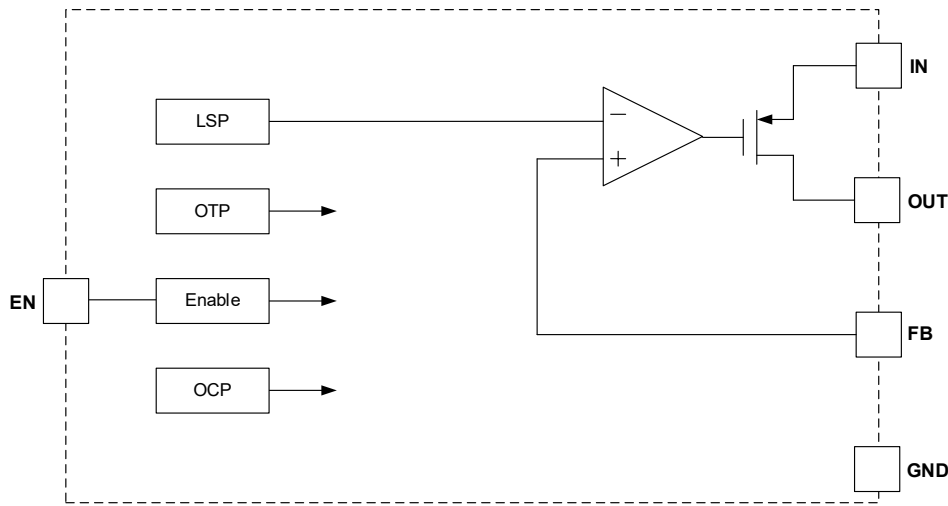

Functional Block Diagram

Specifications

Absolute Maximum Ratings ⁽¹⁾ ⁽²⁾

Item	Min	Max	Unit
V _{IN} voltage	2.0	8.0	V
V _{OUT} voltage	1.0	3.3	V
Output Current ⁽³⁾	600		mA
Power dissipation ⁽⁴⁾	Internally Limited		
Operating Ambient Temperature	-40	85	°C
Maximum junction temperature		150	°C
Storage temperature, T _{stg}	-50	85	°C
Lead Temperature (Soldering, 10sec.)		260	°C

Note (1): Exceeding these ratings may damage the device.

Note (2): The device is not guaranteed to function outside of its operating conditions.

Note (3): $I_{OUT} = P_D / (V_{IN} - V_{OUT})$

Note (4): The maximum allowable power dissipation is a function of the maximum junction temperature, T_{J(MAX)}, the junction-to-ambient thermal resistance, R_{θJA}, and the ambient temperature, T_A. The maximum allowable power dissipation at any ambient temperature is calculated using: $P_{D(MAX)} = (T_{J(MAX)} - T_A) / R_{\theta JA}$. Exceeding the maximum allowable power dissipation causes excessive die temperature, and the regulator goes into thermal shutdown. Internal thermal shutdown circuitry protects the device from permanent damage. Thermal shutdown engages at T_J=155°C (typical) and disengages at T_J= 140°C (typical).

500mA Adjustable High-Speed Low Power LDO

Recommended Operating Conditions

Item	Min	Max	Unit
Operating junction temperature ⁽¹⁾	-40	125	°C
Operating temperature range	-40	85	°C
Input voltage V _{IN}	2	6.5	V
Output current	0	500	mA

Note (1): All limits specified at room temperature (T_A = 25°C) unless otherwise specified. All room temperature limits are 100% production tested. All limits at temperature extremes are ensured through correlation using standard Statistical Quality Control (SQC) methods. All limits are used to calculate Average Outgoing Quality Level (AOQL).

Thermal Information

Item	Description	SOT23 5 Pin	DFN1×1 4 Pin	DFN2×2 6 Pin	Unit
R _{θJA}	Junction-to-ambient thermal resistance ⁽¹⁾⁽²⁾	230	220	96	°C/W
R _{θJC(top)}	Junction-to-case (top) thermal resistance	152	165	90	°C/W
R _{θJB}	Junction-to-board thermal resistance	56	165	66	°C/W
Ψ _{JT}	Junction-to-top characterization parameter	31	5.5	3.2	°C/W
Ψ _{JB}	Junction-to-board characterization parameter	55	164	66	°C/W
R _{θJC(bot)}	Junction-to-case (bottom) thermal resistance	N/A	131	41	°C/W

Note (1): The package thermal impedance is calculated in accordance to JESD 51-7.

Note (2): Thermal Resistances were simulated on a 4-layer, JEDEC board

500mA Adjustable High-Speed Low Power LDO

Electrical Characteristics

T_A = 25°C, unless otherwise noted.

Parameter	Symbol	Test Conditions	Min	Typ.	Max	Units	
Input Voltage	V _{IN}		2		6.5	V	
Feedback Voltage	V _{FB}		780	800	820	mV	
Output Current	I _{OUT}	V _{IN} ≥ V _{OUT(S)} + 1.0V		500		mA	
Dropout Voltage	V _{drop}	I _{OUT} = 50 mA	-	0.10	0.15	V	
		I _{OUT} = 100 mA	-	0.20	0.30		
Line Regulations	$\frac{\Delta V_{OUT}}{\Delta V_{IN} \times V_{OUT}}$	V _{OUT(S)} + 0.5 V ≤ V _{IN} ≤ 7V I _{OUT} = 30mA	-	0.20	0.30	%/V	
Load Regulation	ΔV _{OUT}	V _{IN} = V _{OUT(S)} + 1.0 V 1.0mA ≤ I _{OUT} ≤ 100mA	-	50	100	mV	
Output Voltage Temperature Characteristics	$\frac{\Delta V_{OUT}}{T_A \times V_{OUT}}$	V _{IN} = V _{OUT(S)} + 1.0V, I _{OUT} = 10mA -40°C ≤ T _A ≤ 85°C	-	±100	-	ppm/ °C	
Supply Current	I _{SS1}	V _{IN} = V _{OUT(S)} + 1.0 V	-	50	120	μA	
Shutdown Current	I _{shut}	V _{IN} = 5V, V _{EN} = 0			0.1	μA	
Power Supply Rejection Ratio	PSRR	V _{OUT} = 1.2V, V _{IN} = 2V	f = 100Hz	-	70	-	dB
			f = 1kHz		65	-	dB
Output Voltage Noise (BW = 10Hz to 100kHz, C _{OUT} = 10μF)		V _{IN} = 3.5V I _{LOAD} = 0.1A	V _{OUT} = 0.9V		30		μV _{RMS}
			V _{OUT} = 2.8V		40		
Short-circuit Current	I _{short}	V _{IN} = V _{OUT(S)} + 1.0V, ON/OFF Terminal is ON, V _{OUT} = 0V	-	100	-	mA	
EN "High Voltage"	V _{ENH}		0.9			V	
EN "Low" Voltage	V _{ENL}				0.4	V	
EN "High Current"	I _{ENH}	V _{IN} = V _{EN} = V _{OUT(T)} + 1V	-0.1		0.1	μA	
EN "Low" Current	I _{ENL}	V _{IN} = V _{OUT(T)} + 1V, V _{EN} = V _{SS}	-0.1		0.1	μA	
Thermal Shutdown Temperature	T _{SD}	I _{LOAD} = 10mA		155		°C	
Thermal Shutdown Hysteresis	ΔT _{SD}				15		°C

500mA Adjustable High-Speed Low Power LDO

Applications Information

Setting the Output Voltage

RY6050-ADJ require an input capacitor and an output capacitor. These components are critical to the performance of the device. The output voltage can be programmed by resistor divider.

$$V_{OUT} = V_{FB} \times \frac{R1 + R2}{R2}$$

V _{OUT} (V)	R1(KΩ)	R2(KΩ)	C _{IN} (μF)	C _{OUT} (μF)
1	25.00	100	1~10	1~10
1.05	31.25	100	1~10	1~10
1.2	50.00	100	1~10	1~10
1.5	87.50	100	1~10	1~10
1.8	125.00	100	1~10	1~10
2.5	212.50	100	1~10	1~10
2.8	250.00	100	1~10	1~10
3.3	312.50	100	1~10	1~10

Low ESR Capacitors

With the RY6050-ADJ series, a stable output voltage is achievable even if used with low ESR capacitors as a phase compensation circuit is built-in. In order to ensure the effectiveness of the phase compensation, we suggest that an output capacitor (C_{OUT}) is connected as close as possible to the output pin (V_{OUT}) and the GND pin. Please use an output capacitor with a capacitance value of 10uF. Also, please connect an input capacitor (C_{IN}) of 10uF between the V_{IN} pin and the GND pin in order to ensure a stable power input. Stable phase compensation may not be ensured if the capacitor runs out capacitance when depending on bias and temperature. In case the capacitor depends on the bias and temperature, please make sure the capacitor can ensure the actual capacitance.

Current Limiter, Short-Circuit Protection

The RY6050-ADJ series includes a combination of a fixed current limiter circuit & a feedback circuit, which aid the operations of the current limiter and circuit protection. When the load current reaches the current limit level, the fixed current limiter circuit operates and output voltage drops. As a result of this drop-in output voltage, the feedback circuit operates, output voltage drops further and output current decreases. When the output pin is shorted, a current of about 50mA flows.

EN pin

The IC's internal circuitry can be shutdown via the signal from the EN pin with the RY6050-ADJ series. Driving EN over 0.9 V turns on the regulator. Driving EN below 0.4 V puts the regulator into shutdown mode. The operational logic of the IC's EN pin is selectable. Note that as the standard RY6050-ADJ type's regulator is 'High Active/No Pull-Down', operations will become unstable with the EN pin open. Although the EN pin is equal to an inverter input with CMOS hysteresis, with either the pull-up or pull-down options, the EN pin input current will increase when the IC is in operation. We suggest that you use this IC with either a V_{IN} voltage or a GND voltage

500mA Adjustable High-Speed Low Power LDO

input at the EN pin. If this IC is used with the correct specifications for the EN pin, the operational logic is fixed and the IC will operate normally. However, supply current may increase as a result of through current in the IC's internal circuitry.

Notes on Use

1. Please use this IC within the stated absolute maximum ratings. The IC is liable to malfunction should the ratings be exceeded.
2. Where wiring impedance is high, operations may become unstable due to noise and/or phase lag depending on output current. Please keep the resistance low between V_{IN} and GND wiring in particular.
3. Please wire the input capacitor (C_{IN}) and the output capacitor (C_{OUT}) as close to the IC as possible.

500mA Adjustable High-Speed Low Power LDO

Packaging Information

5-Pin SOT23 Packaging Information

SOT23-5

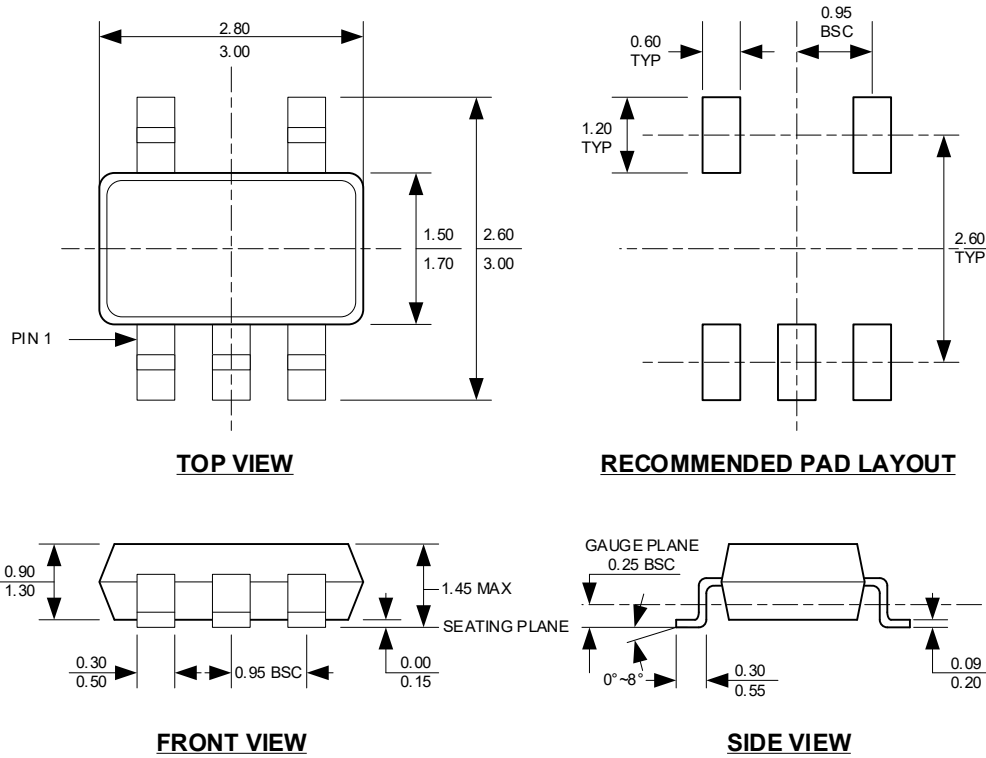

NOTE:

1. CONTROL DIMENSION IS IN INCHES. DIMENSION IN BRACKET IS IN MILLIMETERS.
2. PACKAGE LENGTH DOES NOT INCLUDE MOLD FLASH, PROTRUSIONS OR GATE BURRS.
3. PACKAGE WIDTH DOES NOT INCLUDE INTERLEAD FLASH OR PROTRUSIONS.
4. LEAD COPLANARITY (BOTTOM OF LEADS AFTER FORMING) SHALL BE 0.004" INCHES MAX.
5. DRAWING CONFORMS TO JEDEC MS-012, VARIATION BA.
6. DRAWING IS NOT TO SCALE.

500mA Adjustable High-Speed Low Power LDO

4-Pin DFN1×1 Packaging Information

DFN4-1×1

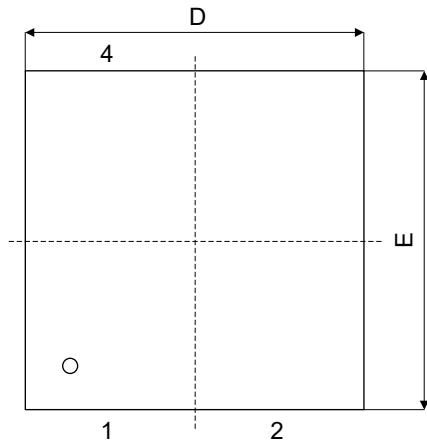

TOP VIEW

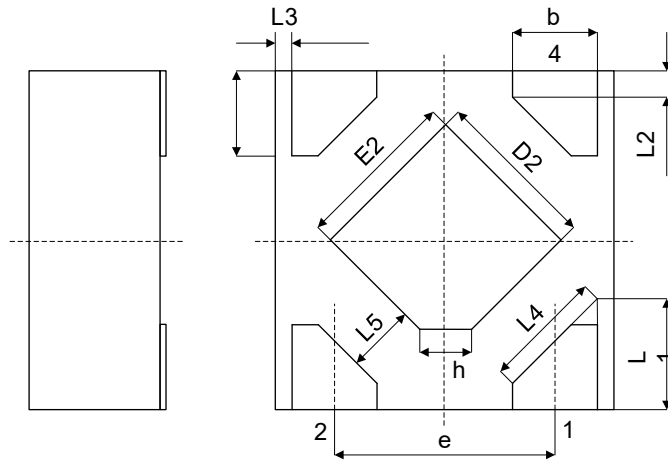

BOTTOM VIEW

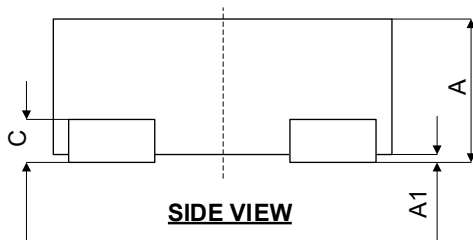

SIDE VIEW

DIM	Min (mm)	Nom (mm)	Max (mm)
Symbol			
A	0.35	-	0.40
A1	0	0.02	0.05
b	0.20	0.25	0.30
c	0.02	0.07	0.17
D	0.95	1.00	1.05
D2	0.38	0.48	0.58
e	0.65BSC		
E	0.95	1.00	1.05
E2	0.38	0.48	0.58
L	0.20	0.25	0.30
L2	0.077REF		
L3	0.05REF		
L4	0.34REF		
L5	0.20REF		
h	0.12REF		

NOTE:

- CONTROL DIMENSION IS IN INCHES. DIMENSION IN BRACKET IS IN MILLIMETERS.
- PACKAGE LENGTH DOES NOT INCLUDE MOLD FLASH, PROTRUSIONS OR GATE BURRS.
- PACKAGE WIDTH DOES NOT INCLUDE INTERLEAD FLASH OR PROTRUSIONS.
- LEAD COPLANARITY (BOTTOM OF LEADS AFTER FORMING) SHALL BE 0.004" INCHES MAX.
- DRAWING CONFORMS TO JEDEC MS-012, VARIATION BA.
- DRAWING IS NOT TO SCALE.

500mA Adjustable High-Speed Low Power LDO

6-Pin DFN2x2 Packaging Information

DFN6-2x2

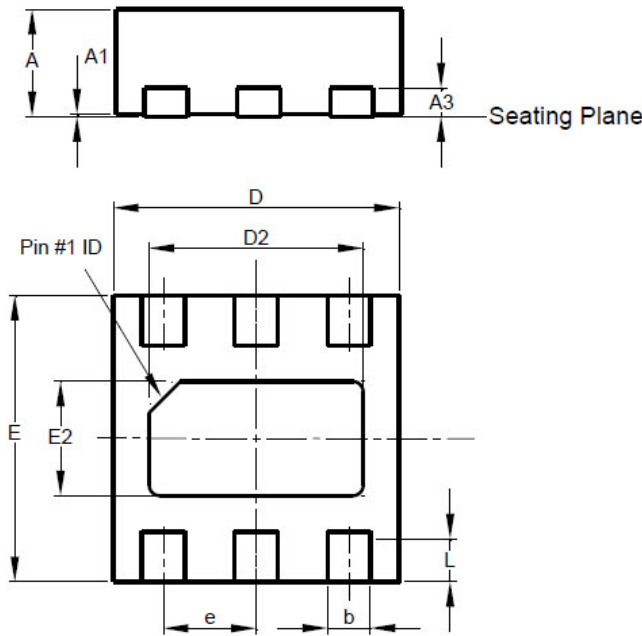

Dim	Min	Max	Typ
A	0.70	0.80	0.75
A1	0.00	0.05	--
A3	0.20 REF		
b	0.25	0.35	0.30
D	1.95	2.075	2.00
D2	1.35	1.60	1.50
E	1.95	2.075	2.00
E2	0.65	0.90	0.80
e	0.65 BSC		
L	0.25	0.45	0.35
All Dimensions in mm			

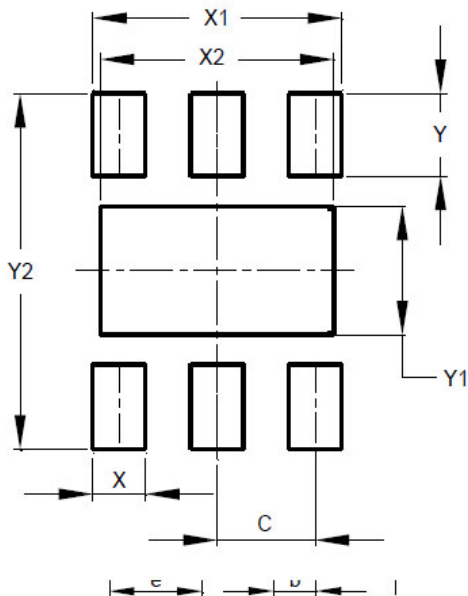

Dimensions	Value (in mm)
C	0.650
X	0.350
X1	1.650
X2	1.550
Y	0.545
Y1	0.850
Y2	2.350