

Over-Voltage Protected Load Switch with Surge Protection

Features

- Surge and ESD protected Input
 - Surge Protection
 - IEC 61000-4-5: > 100V
 - ESD Protection
 - IEC 61000-4-2 (Level 4)
 - Contact: ±8kV
 - Air Gap: ±15kV
 - Human Body Model: ±2kV
- Wide Input voltage range
 - 2.3V to 28V
- Low Quiescent Current: 70µA (typ.)
- Integrated 28mΩ (typ) N-Channel MOSFET
- Fast turn-off response time
 - 100ns
- Flexible trip-point options
 - Fixed 5.95V
 - Adj. 4V to 22V
- Auto-enabled switch with typ. 15ms debounce time
- Additional Under voltage (UVLO), Short-circuit and Thermal shutdown protection
- Open-drain power good output
- Pb-free WLCSP-12 package
- -40°C to +85°C Temperature Range

Brief Description

The KTS1680A over-voltage protection device features an ultra-low 28mΩ (typical) on-resistance high current integrated MOSFET which actively protects low-voltage systems from voltage supply faults up to +28V_{DC}. An internal clamp protects the device from surges up to 100V.

An input voltage exceeding the over-voltage threshold will cause the internal MOSFET to turn off, preventing excessive voltage from damaging downstream devices. When the OVLO input set below the external OVLO select voltage, the KTS1680A automatically chooses the internal fixed OVLO threshold, preset to 5.95V (typical). The over-voltage protection threshold can be adjusted with optional resistor divider to a voltage between 4V and 22V.

The device features an open-drain output \overline{ACOK} indicating a stable supply between the minimum supply voltage and OVLO threshold. The KTS1680A is also protected against over-current faults and has thermal protection.

The KTS1680A is available in a RoHS and Green compliant 12-Bump 1.16mm x 1.65mm x 0.64mm WLCSP.

Applications

- Smartphones
- Tablet Computers
- Mobile Internet Devices
- Peripherals

Typical Application

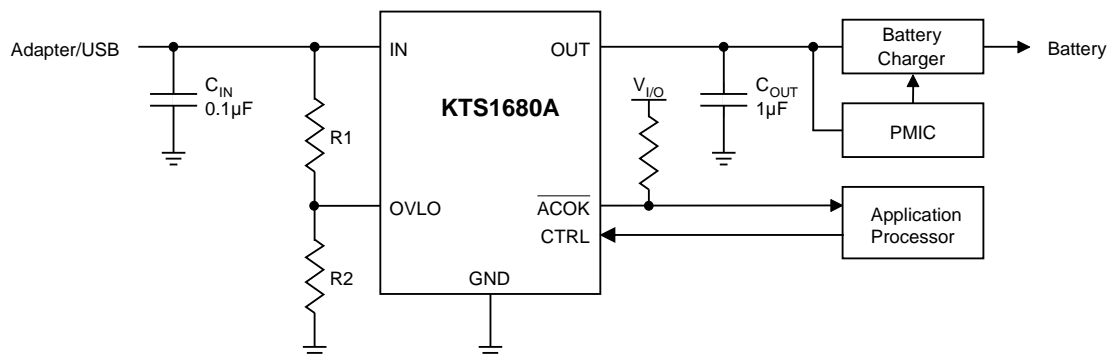

Pin Descriptions

Pin #	Name	Function
A1	CTRL	OUT power path is Enabled when CTRL is logic Low.
A2, A3, B2	OUT	Output of internal main high-current power switch. Connect OUT pins together in the PCB for proper operation.
A4, B4, C4	GND	Ground. Connect GND pins together in the PCB for proper operation.
B1	ACOK	Open-drain power good output. \overline{ACOK} is driven low during normal operation and becomes high impedance when an out-of-range condition is detected. Connect a pull-up resistor between the logic pin and the system rail.
B3, C2, C3	IN	Voltage Input. Connect IN pins together in the PCB for proper operation.
C1	OVLO	External OVLO Adjustment. Connect OVLO to GND when using the internal fixed threshold. Connect a resistor-divider to OVLO to set the adjustable OVLO threshold. The optional external resistor divider is unrelated to the internal threshold.

WLCSP-12

TOP VIEW

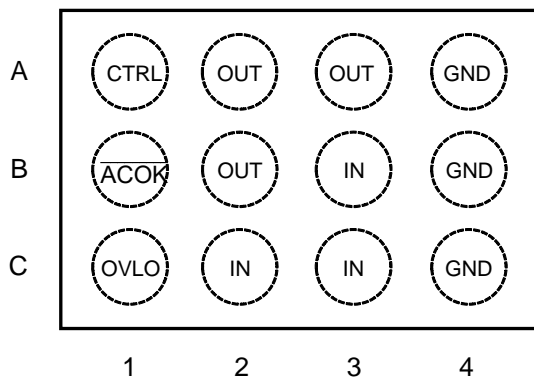

TOP VIEW

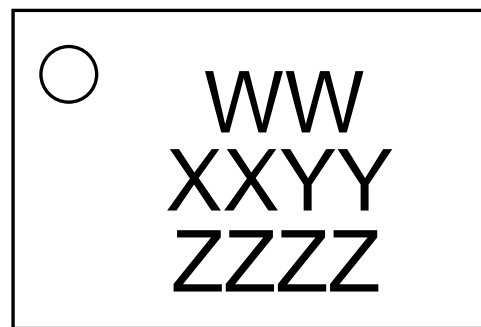

12-Bump 1.16mm x 1.65mm x 0.64mm
WLCSP Package

Top Mark

WW = Device ID Code = LS
XX = Date Code, YY = Assembly Code
ZZZZ = Serial Number

Absolute Maximum Ratings¹

(T_A = 25°C unless otherwise noted)

Symbol	Description	Value	Units
IN ² , OUT	Input, output Voltages	-0.3 to 29	V
OVLO	OVLO Pin	-0.3 to 7	V
CTRL	Control Pin	-0.3 to 6	V
ACOK	ACOK Pin	-0.3 to 6	V
IN, OUT Current	Continuous Current	4.5	A
	Peak Current (10msec)	8	A
T _J	Junction Operating Temperature Range	-40 to 150	°C
T _s	Storage Temperature Range	-65 to 150	°C
T _{LEAD}	Maximum Soldering Temperature (at leads, 10 sec)	260	°C

Thermal Capabilities

Symbol	Description	Value	Units
θ _{JA}	Thermal Resistance – Junction to Ambient ³	73	°C/W
P _D	Maximum Power Dissipation at T _A ≤ 25°C	1.28	W
ΔP _D /ΔT	Derating Factor Above T _A = 25°C	-12.8	mW/°C

Recommended Operating Range

Description	Value
Input Voltage Range	2.3V to 28V
Output Load Capacitance Range	up to 100μF

Ordering Information

Part Number	Marking ⁴	Operating Temperature	Package
KTS1680AEUZ-TR	LSXXYYZZZZ	-40°C to +85°C	WLCSP-12

- Stresses above those listed in Absolute Maximum Ratings may cause permanent damage to the device. Functional operation at conditions other than the operating conditions specified is not implied. Only one Absolute Maximum rating should be applied at any one time.
- Survives burst pulses up to 100V with 2Ω series resistance.
- Junction to Ambient thermal resistance is highly dependent on PCB layout. Values are based on thermal properties of the device when soldered to an EV board
- "XXYYZZZZ" is the date code, assembly code and serial number.

Electrical Characteristics⁵

$V_{IN} = +2.3V$ to $+28V$ and $C_{IN} = 0.1\mu F$. Unless otherwise noted, the *Min* and *Max* specs are applied over the full operation temperature range of $-40^{\circ}C$ to $+85^{\circ}C$, while *Typ* values are specified at room temperature ($25^{\circ}C$). $V_{IN} = 5V$, $I_{IN} \leq 3.5A$.

Symbol	Description	Conditions	Min	Typ	Max	Units
V_{IN}	Input operating range		2.3		28	V
V_{IN_CLAMP}	Input clamp voltage	$I_{IN} = 10mA$, $T_A = +25^{\circ}C$		32		V
I_{IN}	Input supply current	$V_{IN} = 5V$		70	120	μA
I_{IN_Q}	OVLO supply current	$V_{OVLO} = 3V$, $V_{IN} = 5V$, $V_{OUT} = 0V$		63	120	μA
V_{IN_UVLO}	Under voltage lockout threshold	V_{IN} rising		1.9		V
V_{UVLO_HYST}	Under voltage lockout hysteresis			0.1		V
V_{IN_OVLO}	Internal over voltage trip level	V_{IN} rising, $T_A = +25^{\circ}C$	5.68	5.95	6.18	V
$V_{IN_OVLO_HYS}$	OVLO Hysteresis	V_{IN} falling, $T_A = +25^{\circ}C$		0.2		V
V_{OVLO_TH}	OVLO External threshold	$T_A = +25^{\circ}C$	1.15	1.21	1.27	V
	Adjustable OVLO threshold range		4		22	V
V_{OVLO_SEL}	External OVLO select threshold		0.2	0.25	0.3	V
$R_{DS(ON)}$	Switch On-Resistance	$V_{IN} = 5V$, $I_{IN} = 1A$, $T_A = +25^{\circ}C$		28	38	$m\Omega$
I_{OVLO}	OVLO input leakage current	$V_{OVLO} = V_{OVLO_TH}$	-0.1		0.1	μA
CTRL						
V_{CTRL_H}	CTRL logic high threshold		1.4			V
V_{CTRL_L}	CTRL logic low threshold				0.4	V
Digital Signals (\overline{ACOK})						
V_{OL}	\overline{ACOK} output low voltage	$V_{I/O} = 3.3V$, $I_{SINK} = 1mA$			0.4	V
V_{ACOK_LEAK}	\overline{ACOK} leakage current	$V_{I/O} = 3.3V$, \overline{ACOK} de-asserted	-1		1	μA
ESD PROTECTION						
V_{ESD}	Human Body Model (HBM) Model = 2	All pins		± 2		kV
	IEC 61000-4-2 Contact discharge	IN pin		± 8		kV
	IEC 61000-4-2 Air gap discharge	IN pin		± 15		kV
Thermal Shutdown						
T_{SHDN}	Shutdown Temperature			130		$^{\circ}C$
	Shutdown Temperature Hysteresis			20		$^{\circ}C$

5. KTS1680A is guaranteed to meet performance specifications over the $-40^{\circ}C$ to $+85^{\circ}C$ operating temperature range by design, characterization and correlation with statistical process controls.

Timing Characteristics (Figure 1)

Symbol	Description	Conditions	Min	Typ	Max	Units
t_{DEB}	Debounce time	Time from $2.1V < V_{IN} < V_{IN_OVLO}$ to $V_{OUT} = 10\%$ of V_{IN}		15		ms
t_{SS}	Soft-start time	$V_{OUT} = 10\%$ of V_{IN} to soft-start off		15		ms
t_{ON}	Switch turn-on time	$V_{IN} = 5V$, $R_L = 100\Omega$, $C_{LOAD} = 100\mu F$, V_{OUT} from 10%, V_{IN} to 90% V_{IN}		2		ms
t_{OFF}	Switch turn-off time	$V_{IN} > V_{OVLO}$ to $V_{OUT} = 80\%$ of V_{IN} , $R_L = 100\Omega$, V_{IN} rising at $2V/\mu s$		100		ns

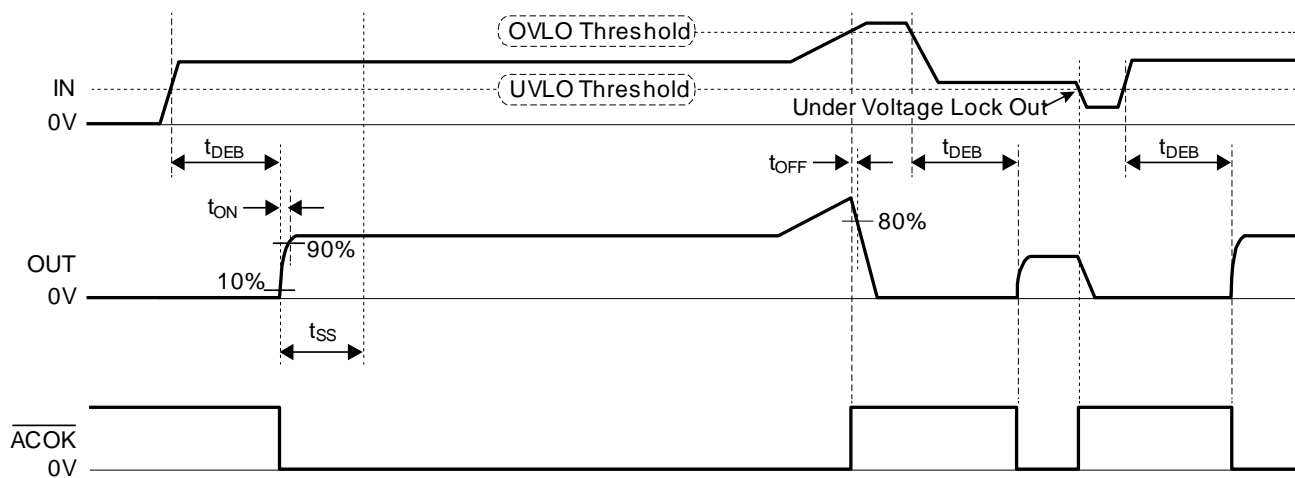
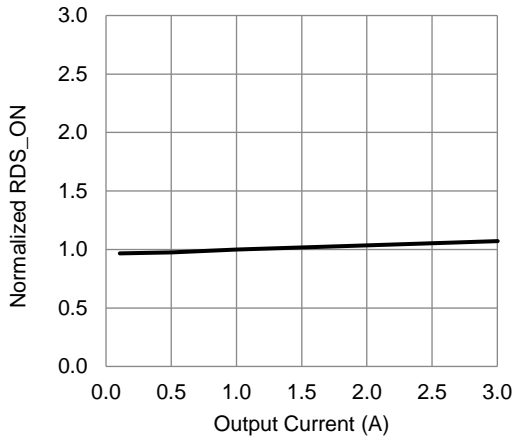

Figure 1. Timing Diagram

Typical Characteristics

$V_{IN} = 5V$, $C_{IN} = 0.1\mu F$, $C_{OUT} = 1\mu F$, OVLO pin = GND, Temp = 25°C unless otherwise specified.

Normalized $R_{DS_{ON}}$ vs. Output Current



Normalized $R_{DS_{ON}}$ vs. Temperature

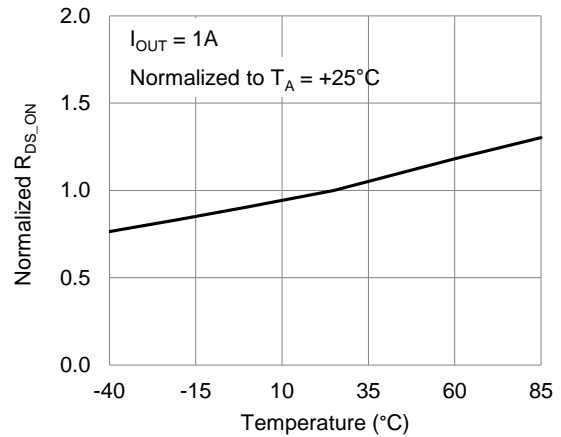

Input Supply Current vs. Input Voltage (no load)

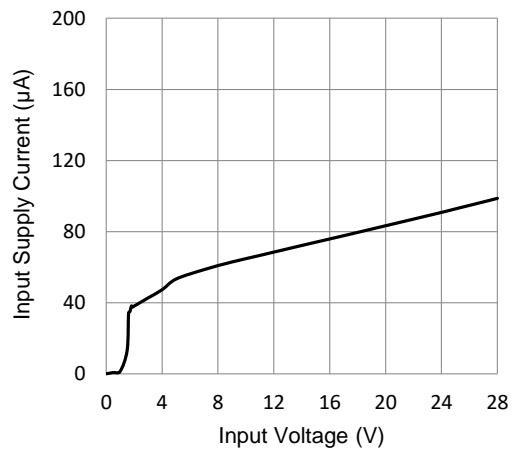

Normalized Debounce Time vs. Temperature

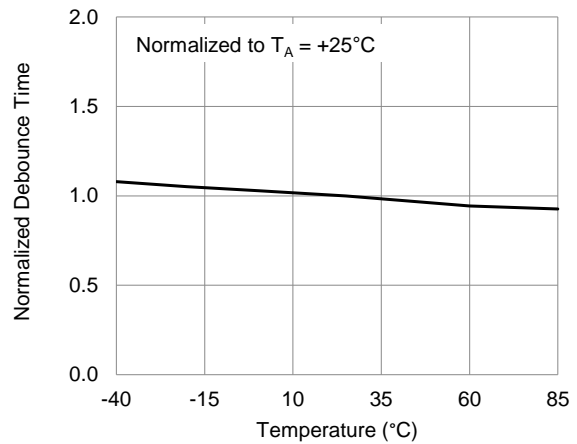

Normalized Fixed OVLO vs. Temperature (OVLO pin GND)

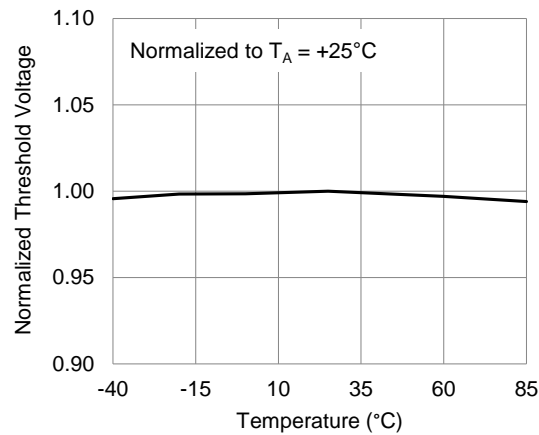

Normalized Adjustable OVLO Threshold vs. Temperature

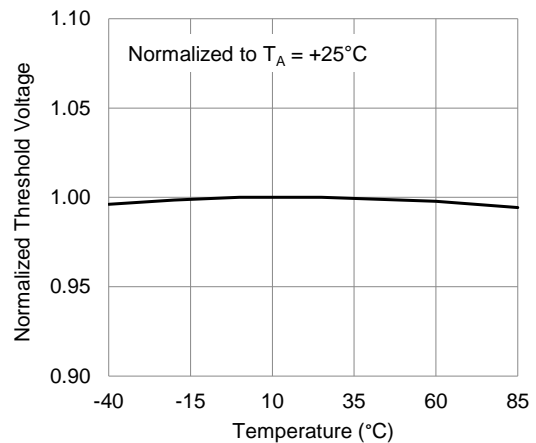

Functional Block Diagram

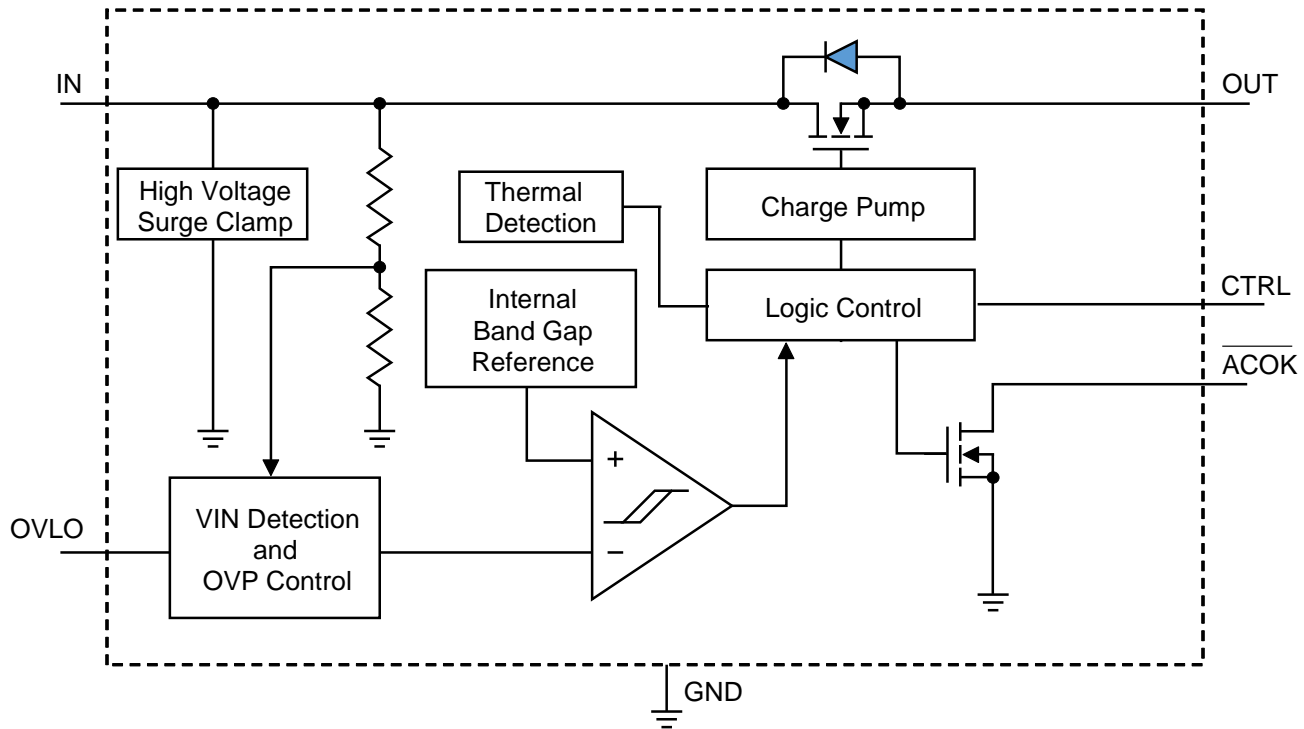

Functional Description

The KTS1680A is inserted between the power supply or charger source and the load to be protected. The KTS1680A consists of a low resistance switch, under-voltage lockout protection (UVLO), over-voltage monitor and protection (OVLO) and an \overline{ACOK} output flag.

The KTS1680A switch device features a low on-resistance ($R_{DS(ON)}$) internal N-Channel MOSFET and protects low-voltage systems against voltage faults up to +28VDC. An internal clamp also protects the device from input surge transients up to 100V. If the input IN pin voltage exceeds the overvoltage threshold, the internal FET is turned off to prevent damage to any downstream components connected to the output. A 15ms debounce time built into the device delays the internal FET turn on time.

The power good flag (\overline{ACOK}) output pin can notify the system of the normal operation by pulling its output low. When an input power over-voltage or over-temperature occurs, the device releases the internal open-drain and the \overline{ACOK} output is set to logic high by the external pull-up resistor in order to alert the system.

UVLO (Under Voltage Lockout)

The device has a built-in under voltage lock out (UVLO) circuit. During V_{IN} positive going slope, the output (OUT) remains disconnected from the input (IN) until V_{IN} voltage exceeds V_{IN_UVLO} 1.9V typical. This circuit has a 100mV hysteresis to provide noise immunity.

OVLO (Over Voltage Lockout)

The KTS1680A can be configured for either an internal OVLO threshold, or an adjustable threshold when using the OVLO pin as a sense pin.

By connecting the OVLO pin to ground, the internal OVLO comparator uses the internally fixed OVLO value V_{IN_OVLO} of 5.95V typical.

If an external resistor-divider is connected to OVLO and V_{OVLO} exceeds the OVLO select voltage, V_{OVLO_SELECT} , the internal OVLO comparator reads the IN fraction fixed by the external resistor divider. Starting with $R_1 = 1M\Omega$ to minimize current consumption, R_2 can be calculated from the following formula:

$$V_{OVLO_EXT} = V_{OVLO_THRESH} \times \left(1 + \frac{R_1}{R_2}\right)$$

Internal MOSFET Switch

In normal operating mode (main power switch turned on), the CTRL input must be set to the logic low state (CTRL = GND). The KTS1680A incorporates an internal N-Channel MOSFET with ultra-low R_{DS} on-resistance of 28m Ω (typ). The MOSFET is internally driven by a charge pump that generates a necessary gate voltage above IN.

ACOK Output

The \overline{ACOK} output is an active-low open-drain flag reporting good operation of the device. A pull-up resistor should be connected from the \overline{ACOK} pin to the system I/O rail. A fault is flagged when the output is being pulled high in the case of an over-voltage or over-temperature fault occurring.

Thermal Protection

The internal FET turns off when the junction temperature exceeds +130°C (typ). The device exits thermal shutdown after the junction temperature cools by 20°C (typ) hysteresis.

Input Capacitor

A 0.1 μ F or larger capacitor is typically recommended for CIN which should be located as close to the device IN pin as possible. For higher current operation, ceramic capacitors are recommended for CIN. During surge voltage transients, the internal input clamp keeps the input IN pin voltage below 40V, so 50V rated capacitors are ideal for most OVP applications.

Output Capacitor

A small output capacitor COUT can be added to accommodate various load transient condition.

USB On-The-GO (OTG) Operation

When used in an OTG application the KTS1680 can provide power from OUT to IN. Initially, the OTG voltage applied at OUT will forward bias the power switch bulk diode and present a voltage drop of approximately 0.7V between OUT and IN. The maximum current in this mode is limited by the thermal performance of the device and at an ambient temperature of 25°C

$$I_{MAX} = \frac{1.28W}{0.7V} = 1.82A$$

This is purely a transitional condition as once the voltage at IN exceeds the UVLO voltage of 1.9V and the debounce time of 15ms has elapsed, the main power switch will turn fully ON, significantly reducing the voltage drop from OUT to IN.

Packaging Information

WLCSP-12, 1.16mm x 1.65mm x 0.64mm

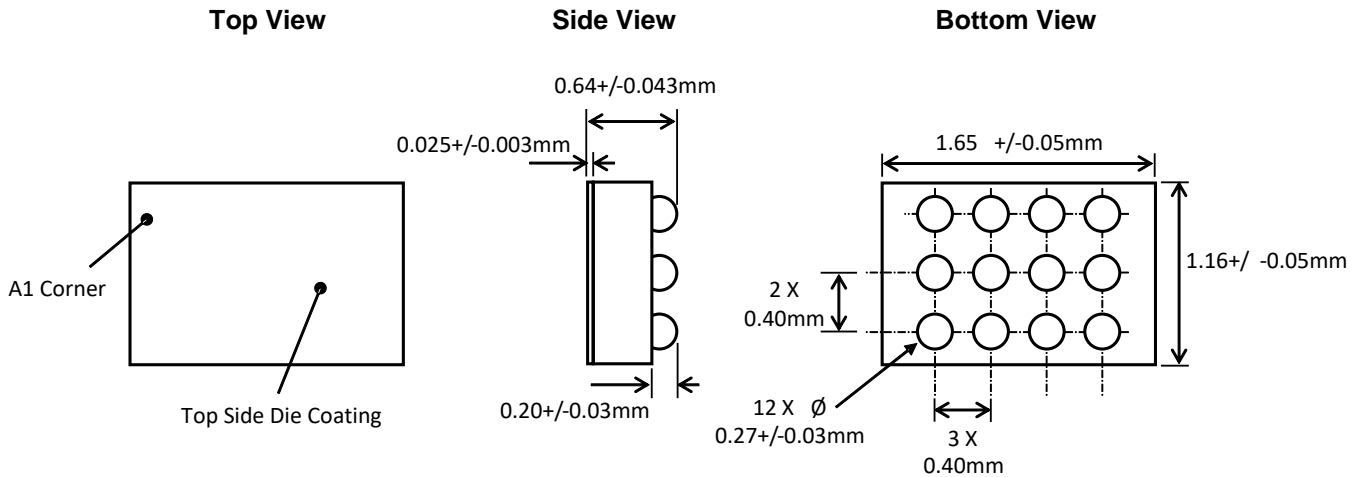

Recommended Footprint

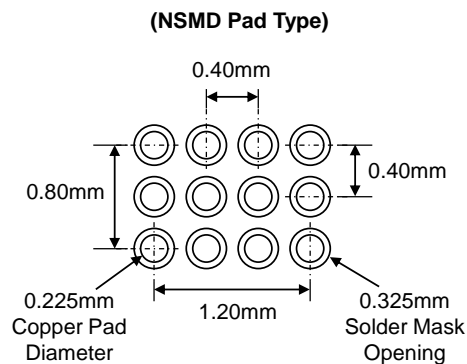

* Dimensions are in millimeters.

Kinetic Technologies cannot assume responsibility for use of any circuitry other than circuitry entirely embodied in a Kinetic Technologies product. No intellectual property or circuit patent licenses are implied. Kinetic Technologies reserves the right to change the circuitry and specifications without notice at any time.