

SCM3402ASI Half-Duplex RS485/RS422 Transceiver

Features

- 3.3V voltages supply, half-duplex
- 1/8 Unit Load—Up to 256 Nodes on a Bus
- Driver short circuit protection
- Over temperature protection
- Low power consumption shutdown function
- Receiver open circuit expired protection
- Stronger anti-chirp capacity
- The in a sudden changing of the integration voltage boycotts function
- Communication Speed up to 12Mbps in an electrical noise environment

Applications

- Industrial automation
- Building automation
- Smart meter
- Long-distance signal interaction and transmission

Package

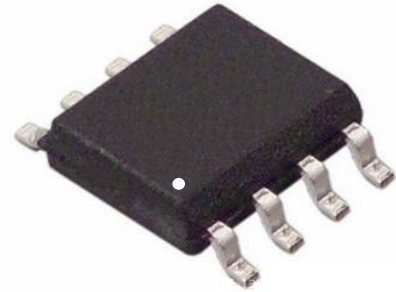

Product optional package: SOP-8, Screen Printing information please see "Ordering Information"

Functional Description

The SCM3402ASI is a 3.3V powered, half-duplex, low-power RS-485 transceiver that fully meets the requirements of the TIA/EIA-485 standard.

The SCM3402ASI includes a driver and a receiver, both of which can be independently enabled and disabled. When both are disabled, both the driver and the receiver output a high-impedance state. The SCM3402ASI has a 1/8 load that allows 256 SCM3402ASI transceivers to be connected to the same communication bus. Error-free data transfer of up to 12Mbps is possible.

The SCM3402ASI operates from a voltage range of 3.0 to 3.6 V and features fail-safe, over-temperature protection, current limit protection, and overvoltage protection.

Typical Application

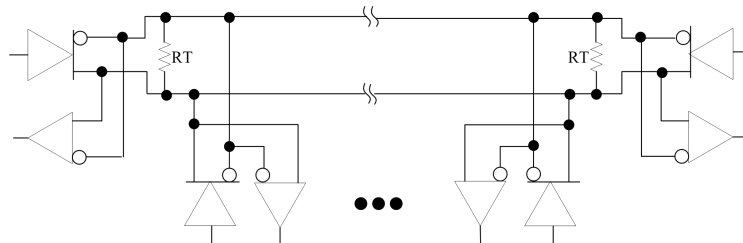

Figure 1. Typical application 1 (Half-Duplex network structure)

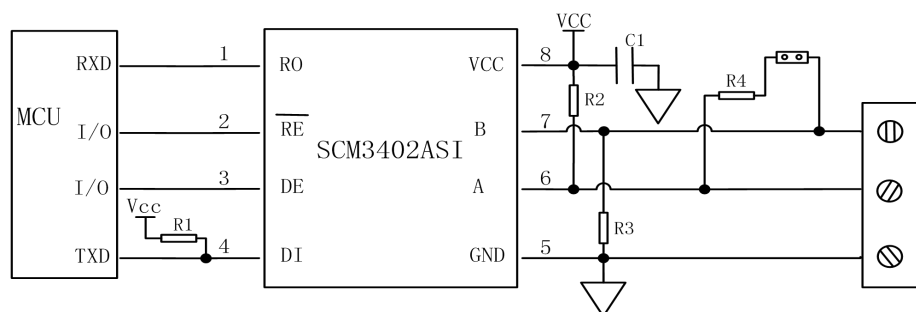
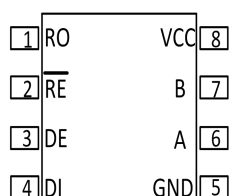

Figure 2. Typical application 2 (Typical design)

Contents

Feature.....	1	Recommended Operating Conditions.....	3
Applications.....	1	Electrical Characteristics.....	3
Functional Description.....	1	Switching Characteristics.....	4
Typical Application.....	1	Parameter Test Circuit.....	4
Pin Package.....	2	General Description.....	6
Internal Block Diagram.....	2	Design Circuit Expansion.....	8
Truth Table.....	2	Power Usage Recommendations.....	8
Pin Configurations and Functions.....	2	Ordering Information.....	8
Absolute Maximum Ratings.....	2	Packaging Information.....	9
		Tape & Reel Information.....	9

Pin Package



Internal Block Diagram

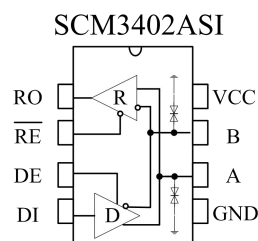

Truth Table

Driver					Receiver			
Input			Output		Input			Output
/RE	DE	DI	A	B	/RE	DE	A-B	RO
X	1	1	H	L	0	X	$\geq 200\text{mV}$	H
X	1	0	L	H	0	X	$\leq -200\text{mV}$	L
0	0	X	Z	Z	0	X	Open/Short circuit	H
1	0	X	Z(shutdown)		1	X	X	Z
X: Don't care; Z: High impedance					X: Don't care; Z: High impedance			

Pin Configurations and Functions

Pins	Name	Pin Functions
1	RO	Receiver output port; When /RE is low-level: if $A-B \geq 200\text{mV}$, RO output high-level; If $A-B \leq -200\text{mV}$, RO output low-level.
2	/RE	Receiver output enable control. When /RE is low-level, receiver output enable, RO output be available; When /RE is high-level, receiver output disable, RO is High impedance state; /RE is high-level and DE is low-level, the spare part enters a low power consumption mode.
3	DE	Driver output enable control. DE is high-level driver output be available, DE is low-level output High impedance; /RE is high-level and DE is low-level, the spare part enters a low power consumption mode.
4	DI	DI device input. When DE is high-level, The DI low level makes the driver co-phase carries A output for low level, the driver anti-phase carries the B output as high level; The DI high level will make co-phase port output for high level, the anti-phase carries output for low.
5	GND	Ground
6	A	Receiver co-phase input and driver co-phase the output carry.
7	B	Receiver anti-phase input and driver anti-phase the output carry.
8	VCC	Supply voltage.

Absolute Maximum Ratings

Parameters	Sym.	Value	Units
Supply Voltage	VCC	+7	V
Voltage of Control Port	/RE, DE, DI	-0.3 ~ +7	V
Bus Side Input Voltage	A, B	-7 ~ 13	V
Receiver Output Voltage	RO	-0.3 ~ +7	V

Operating Ambient Temperature Range		-40 ~ 85	°C
Storage Temperature Range		-60 ~ 150	°C
Welding Temperature Range		300	°C
Continuous Power Dissipation	SOP8	400	mW

(1)The following data was measured in a naturally ventilated, normal operating temperature range (unless otherwise stated).

(2)The maximum limit parameter value means that exceeding these values may cause irreparable damage to the device. Under these conditions, it is not conducive to the normal operation of the device. Continuous operation of the device at the maximum allowable rating may affect device reliability. The reference point for all voltages is ground.

Recommended Operating Conditions

Recommended Operating Conditions	Min.	Typ.	Max.	Units
Supply Voltage, V_{VCC}		3.3		V
Any Bus Terminating Pin Voltage (Differential mode; Common mode), V_I	-7		12	
High-level Input voltage(DI, DE, /RE), V_{IH}	2		VCC	
Low-level Input Voltage(DI, DE, /RE), V_{IL}	0		0.8	
Differential Load resistance	54	60		Ω
Baud Rate			12000	Kbps
Operating Ambient Temperature Range, T_A	-40		85	°C

Electrical Characteristics

Unless otherwise stated, $V_{CC}=3.3V\pm 10\%$, $Temp=T_{MIN}\sim T_{MAX}$, typical value is $V_{CC}=+3.32V$, $Temp=25^\circ C$

Driver Electrical Characteristics						
Sym.	Parameters	Test Conditions	Min.	Typ.	Max.	Units
V_{OD1}	Driver differentially output (no load)			3.3		V
V_{OD2}	Drive differentially output	Figure 3, $R_L = 54\Omega$	1.5		VCC	V
		Figure 3, $R_L = 100\Omega$	2		VCC	V
ΔV_{OD}	(NOTE1)	Figure 3, $R_L = 54\Omega$			0.2	V
V_{OC}	Output common mode voltage	Figure 3, $R_L = 54\Omega$			3	V
ΔV_{OC}	The change of output common mode voltage(NOTE1)	Figure 3, $R_L = 54\Omega$			0.2	V
V_{IH}	High-level voltage input	DE, DI, /RE	2.0			V
V_{IL}	Low-level voltage input	DE, DI, /RE			0.8	V
I_{IN1}	Logic input current	DE, DI, /RE	-2		2	uA
I_{OSD1}	Output short-circuit current, short-circuit to high	short-circuit 0V ~ 12V			250	mA
I_{OSD2}	Output short-circuit current, short-circuit to low	short-circuit -7V ~ 0V	-250			mA
	Temperature threshold of over temperature shut-down			140		°C
	Hyteresis temperature of over temperature shut-down			20		°C
Receiver Electrical Characteristics						
Sym.	Parameters	Test Conditions	Min.	Typ.	Max.	Units
I_{IN2}	Input current(A, B)	DE = 0 V, $V_{CC}=0$ or 3.3V, $V_{IN} = 12$ V			125	uA
		DE = 0 V, $V_{CC}=0$ or 3.3V, $V_{IN} = -7$ V	-100			uA
V_{IT+}	Positive-going input threshold voltage	$-7V \leq V_{CM} \leq 12V$			+200	mV
V_{IT-}	Negative-going input threshold voltage	$-7V \leq V_{CM} \leq 12V$	-200			mV
V_{hys}	Hysteresis voltage	$-7V \leq V_{CM} \leq 12V$	10	30		mV
V_{OH}	High-level output voltage	$I_{OUT} = -2.5mA$, $V_{ID} = +200$ mV	VCC-1.5			V
V_{OL}	Low-level output voltage	$I_{OUT} = +2.5mA$, $V_{ID} = -200$ mV			0.4	V
I_{OZR}	Three state input leak current	0.4 V < V_o < 2.4 V			±1	uA
R_{IN}	Receive port input resistance	$-7V \leq V_{CM} \leq 12V$	96			kΩ
I_{OSR}	Receiver short-circuit current	0 V ≤ V_o ≤ VCC	±8		±60	mA
Power Supply Features						
I_{CC1}	Supply current	/RE=0V, DE = 0 V		520	800	uA

I_{CC2}		/RE=VCC, DE=VCC		540	700	uA
I_{SHDN}	Shut-down Current	/RE=VCC, DE=0V		0.5	10	uA

(If not stated otherwise, VCC=3.3V±10%, Temp=TMIN~TMAX, typical value is VCC=+3.3V, Temp=25° C)

NOTE1: ΔVOD and ΔVOC are the changes in VOD and VOC amplitude caused by the change of DI state of the input signal.

Switching Characteristics

Unless otherwise stated, VCC=3.3V±10%, Temp=TMIN~TMAX, typical value is VCC=+3.3V, Temp=25°C

Driver Switching Characteristics						
Sym.	Parameters	Test Conditions	Min.	Typ.	Max.	Units
t_{DD}	Driver differentially, output delay	$R_{DIFF} = 60 \Omega$, $C_{L1}=C_{L2}=100pF$ (Figure4 与 Figure 5)		10	35	nS
t_{TD}	Driver differentially output, transfer time			12	25	nS
t_{PLH}	Driver input to output, low to high	$R_{DIFF} = 27 \Omega$, (Figure4 与 Figure 5)		8	35	nS
t_{PHL}	Driver input to output, high to low			8	35	nS
t_{PDS}	$ t_{PLH} - t_{PHL} $			1	8	nS
t_{PZH}	Driver enable to output high	$R_L = 110\Omega$, (Figure6, 7)		20	90	nS
t_{PZL}	Driver enable to output low			20	90	nS
t_{PLZ}	Input low to disable	$R_L = 110\Omega$, (Figure6, 7)		20	80	nS
t_{PHZ}	Input high to disable			20	80	nS
t_{DSH}	Under shoutdown, enable to output high	$R_L = 110\Omega$, (Figure6, 7)		500	900	nS
t_{DSL}	Under shoutdown, enable to output low	$R_L = 110\Omega$, (Figure6, 7)		500	900	nS
Receiver Switching Characteristics						
Sym.	Parameters	Test Conditions	Min.	Typ.	Max.	Units
t_{RPLH}	Receiver input to output dealy (low to high)	$C_L=15pF$ Figure 8 and Figure 9		80	150	nS
t_{RPHL}	Receiver input to output dealy (high to low)			80	150	nS
t_{RPDS}	$ t_{RPLH} - t_{RPHL} $			7	10	nS
t_{RPZL}	Enable to output low	$C_L=15pF$, Figure 8 and Figure 9		20	50	nS
t_{RPZH}	Enable to output high	$C_L=15pF$, Figure 8 and Figure 9		20	50	nS
t_{PRLZ}	Output low to disable	$C_L=15pF$, Figure 8 and Figure 9		20	45	nS
t_{PRHZ}	Output high to disable	$C_L=15pF$, Figure 8 and Figure 9		20	45	nS
t_{RPSH}	Under shoutdown, enable to output high	$C_L=15pF$, Figure 8 and Figure 9		200	1400	nS
t_{RPSL}	Under shoutdown, enable to output low	$C_L=15pF$, Figure 8 and Figure 9		200	1400	nS
t_{SHDN}	Enter shoutdown state	NOTE2	80		300	nS

NOTE2: When /RE=1, DE=0 continuously time is smaller than 80ns, The spare part necessarily doesn't enter shut-down state, when it is more than 300ns, necessarily enter shutdown state.

Parameter Test Circuit

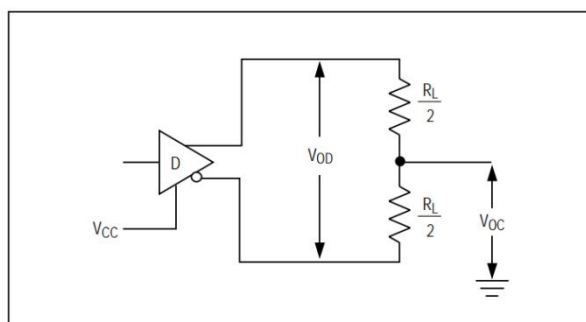
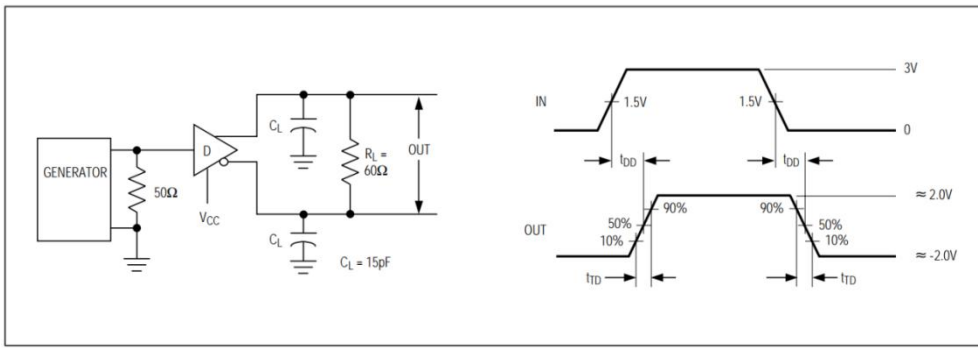

Figure3. Driver DC testing load



CL includes probe and stray capacitance(Down together)

Figure4. Driver differential delay and transfer time

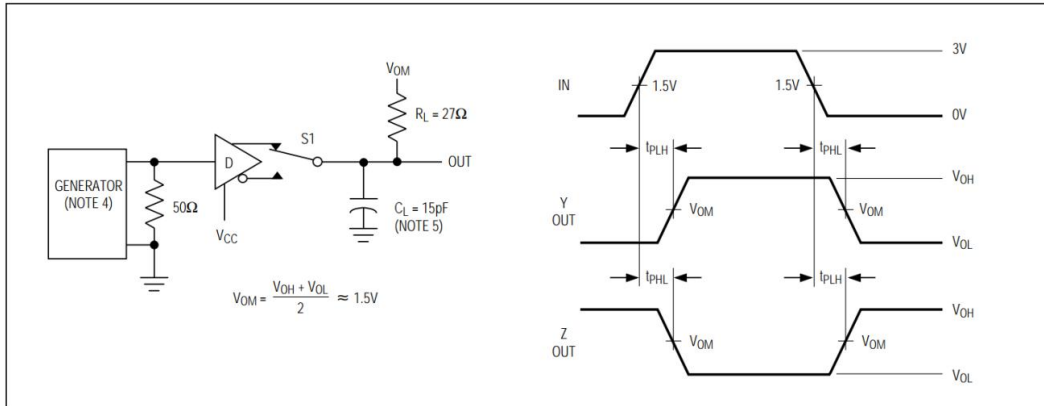

Figure 5. Driver propagation delay

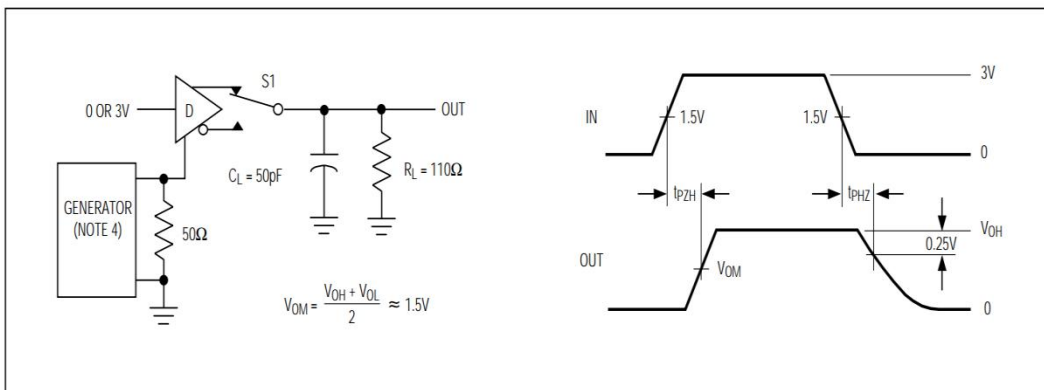

Figure 6. Driver enable and disable time

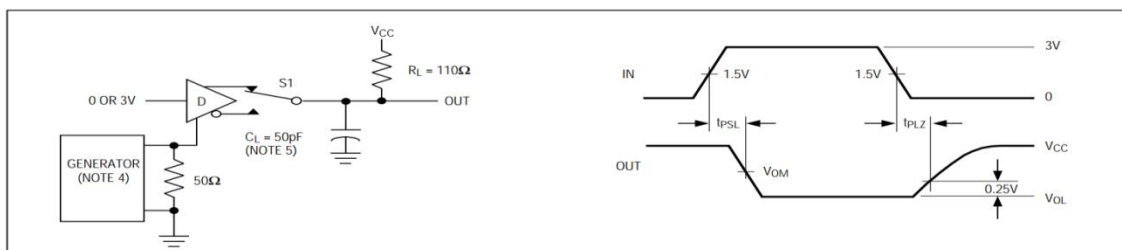

Figure 7. Driver enable and disable time

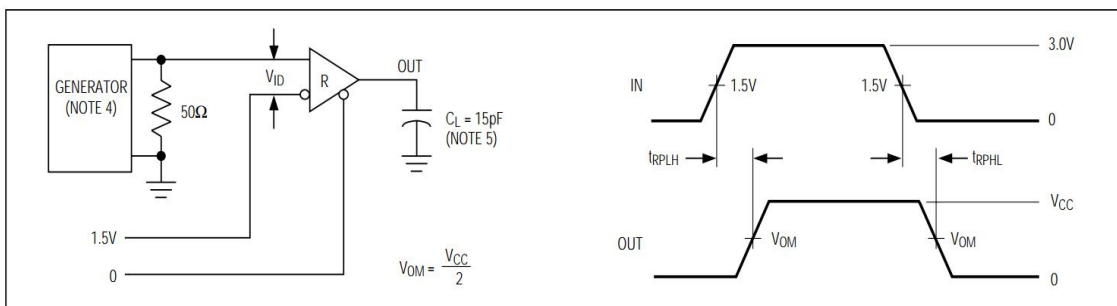

Figure 8. Receiver propagation delay test circuit

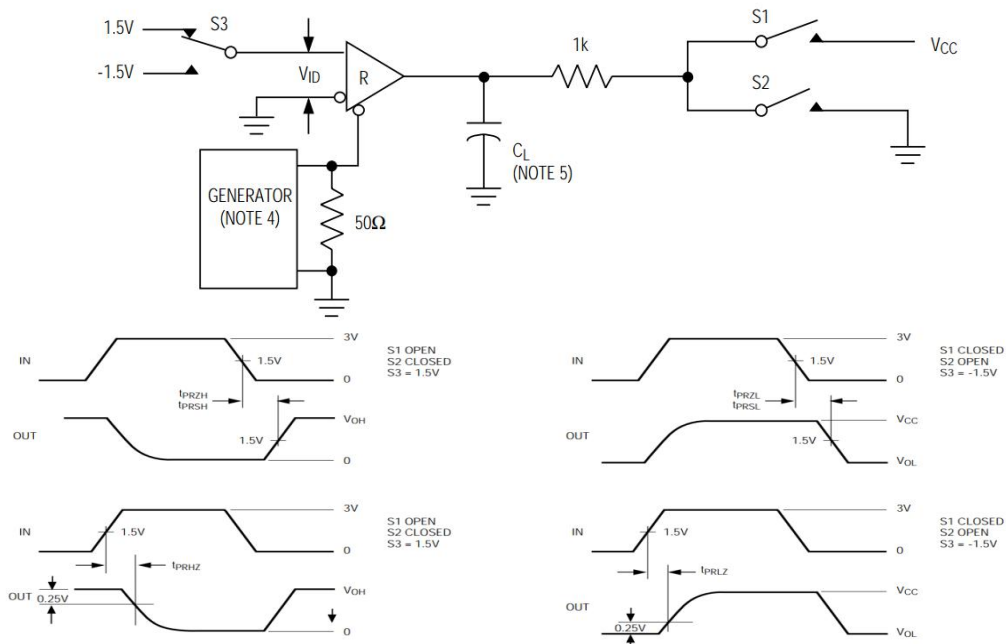

Figure 9. Receiver enable and disable time

General Description

The SCM3402ASI is a half-duplex high-speed transceiver for RS-485/RS-422 communications and includes a driver and receiver. With fail-safe, over voltage protection, over current protection, and overheat protection. The SCM3402ASI enables error-free data transmission up to 12Mbps.

256 transceivers are attached to the bus: the standard RS485 receiver has an input impedance of 12kΩ (1 unit load) and the standard driver can drive up to 32 unit loads. The receiver of the SCM3402ASI transceiver has a 1/8-unit load input impedance (96kΩ) that allows up to 256 transceivers to be mounted in parallel on the same communication bus. These devices can be combined in any combination or combined with other RS485 transceivers and can be attached to the same bus as long as the total load does not exceed 32 unit loads.

Driver Output Protection: Avoiding faults or bus collisions that cause excessive output current and excessive power consumption through two mechanisms. First, over current protection provides fast short-circuit protection over the entire common-mode voltage range (refer to typical operating characteristics). Second, the thermal shutdown circuit forces the driver output into a high-impedance state when the die temperature exceeds 140 °C.

Bus networking: The SCM3402ASI RS485 transceiver is designed for bidirectional data communication on multi-point bus transmission lines. Figure 10 shows a typical network application circuit. These devices can also be used as linear repeaters with cable lengths longer than 4000 feet. To reduce reflections, terminal matching should be done at both ends of the transmission line with their characteristic impedance, and the length of the branch wires other than the main line should be as short as possible.

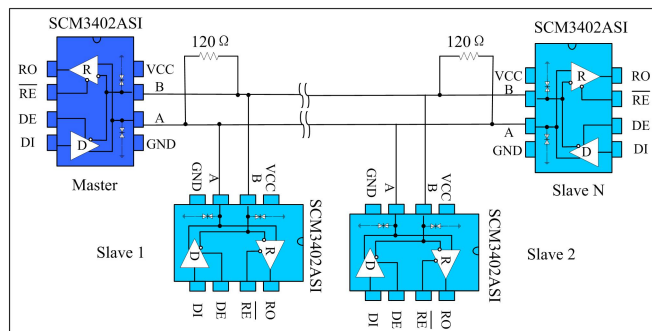

Figure 10. Bus lines type RS485 half-duplex telecommunication network

Hand-in-hand networking: Also known as daisy chain topology, it is the standard and specification of RS485 bus wiring, and is the recommended RS485 bus topology for organizations such as TIA. The wiring mode is that the main control device forms a hand-in-hand connection with a plurality of slave devices, as shown in Figure 11, the branch is not left. This wiring method has the advantages of small signal reflection and high communication success rate.

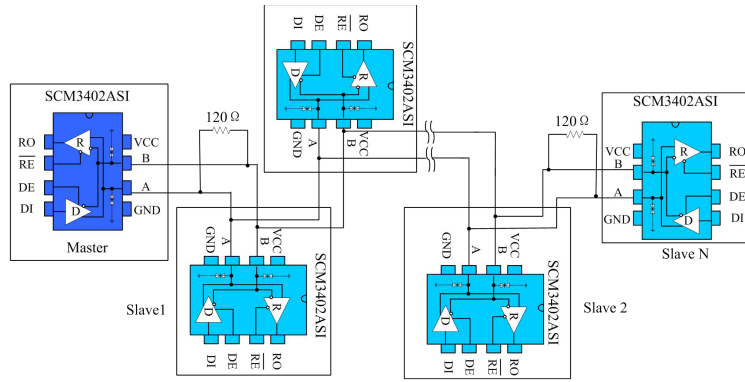

Figure 11. Hand in hand type RS485 half-duplex telecommunication network

Bus port protection: In harsh environments, RS485 communication ports usually have additional protection against static electricity protection, lightning surge protection, and even need to prevent 380V power supply access to avoid smart meters and industrial control hosts. Damage. Figure 12 shows three common RS485 bus port protection schemes. The first is to connect the TVS device to the protection ground in parallel with the AB port, the TVS device in parallel with the AB port, the thermistor in series with the AB port, and the three-stage protection scheme by connecting the gas discharge tube to the protection ground; the second is AB. Parallel TVS to ground, series thermistor, AB parallel varistor three-stage protection scheme; third is AB connected to pull-down resistor to power and ground, AB connected to TVS, A or B port Connect the thermistor solution.

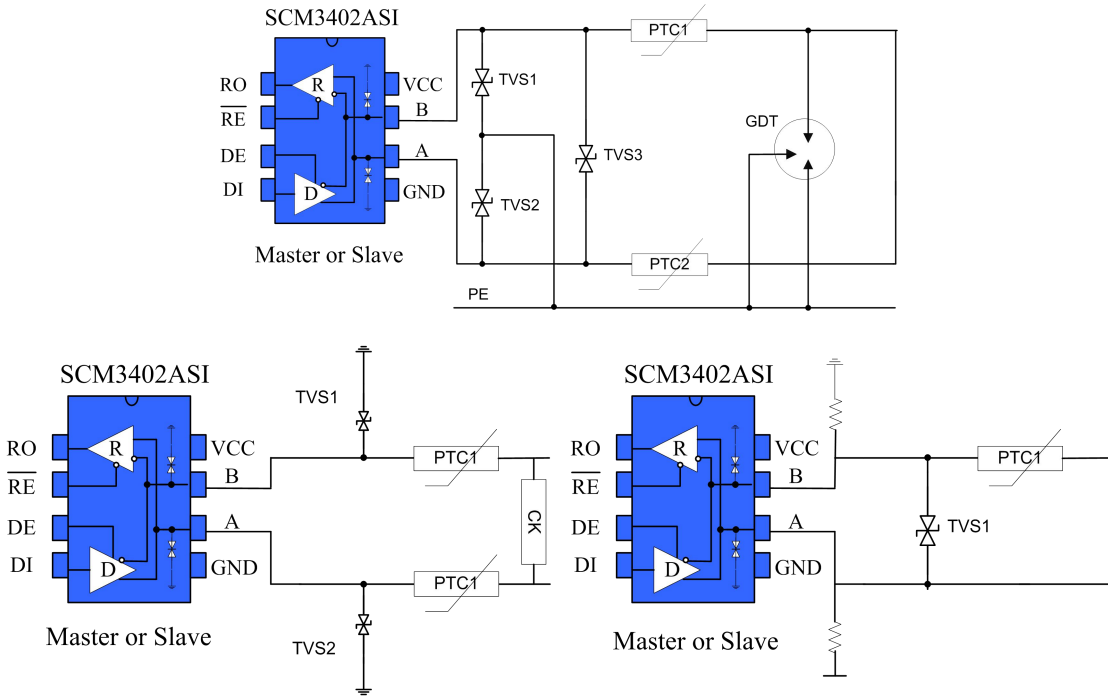

Figure 12. Port safeguard scheme

Design Circuit Expansion

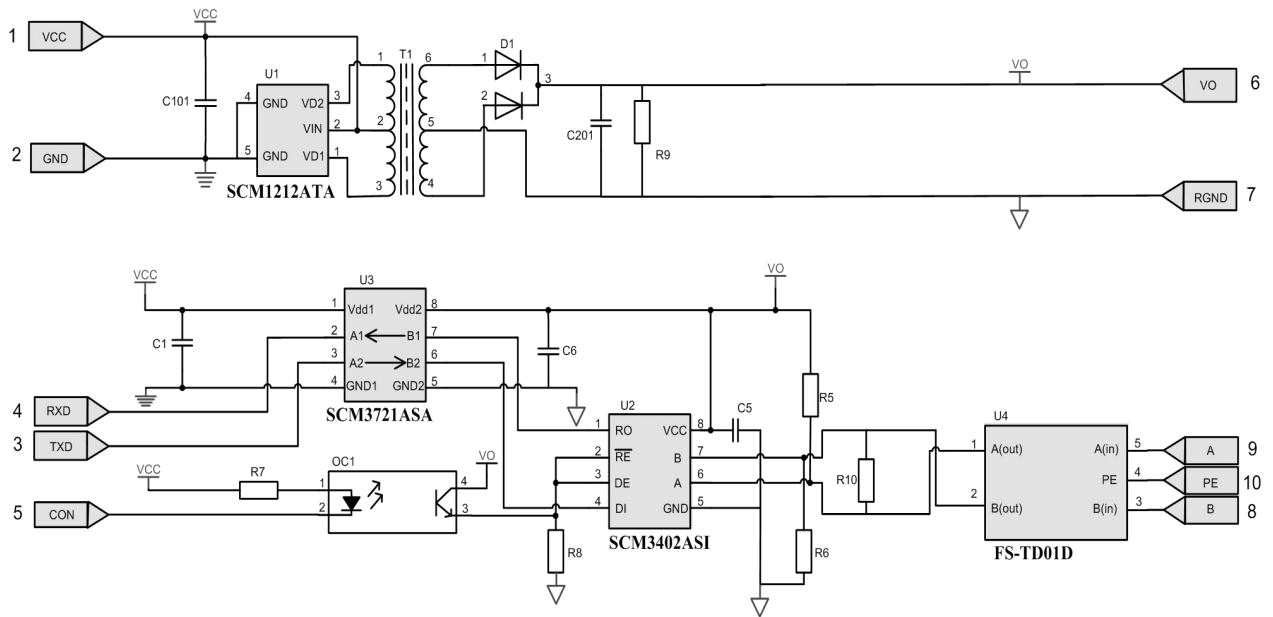

Figure 13. Isolated Application Circuit Schematic for Converting UART to RS485

Power Usage Recommendations

Connecting the 0.1 μ F bypass capacitor as close as possible to the VCC pin of the device.

Ordering Information

Product number	Package Type	Pins	Screen Printing	package
SCM3402ASI	SOP	8	SCM 3402ASI YM	2.5K/reel

Product model and Screen Printing instructions:

SCM3402XYZ:

(1)SCM3402, Product Code.

(2)X = A-Z, Version code.

(3)Y = S Package code; S: SOP package.

(4)Z = C, I, A, M, Temperature class code; C: 0 $^{\circ}$ C - 70 $^{\circ}$ C, I: -40 $^{\circ}$ C-85 $^{\circ}$ C, A: -40 $^{\circ}$ C - 125 $^{\circ}$ C, M: -55 $^{\circ}$ C - 125 $^{\circ}$ C.

(5)YM: Product traceability code; Y: Product year code, M: Product production month code.

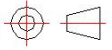
THIRD ANGLE PROJECTION 

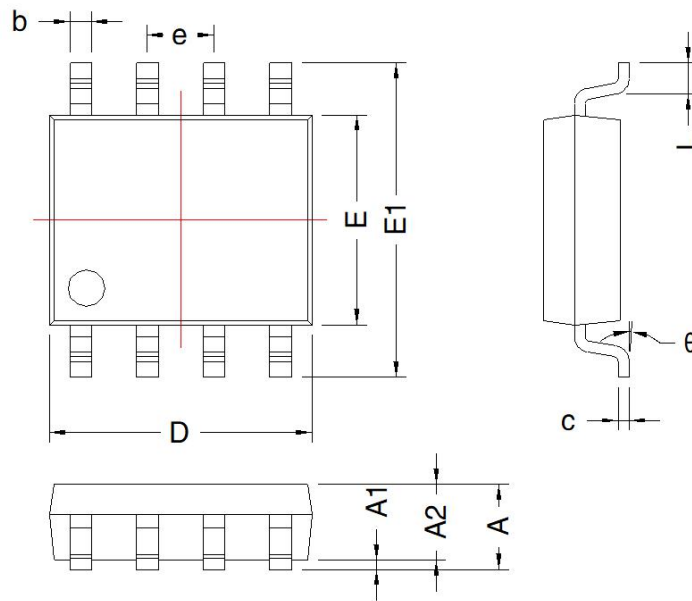

SOP-8				
Mark	Dimension(mm)		Dimension(inch)	
	Min	Max	Min	Max
A	1.5	1.7	0.059	0.067
A1	0.1	0.2	0.004	0.008
A2	1.35	1.55	0.004	Min
D	4.8	5.0	0.053	0.197
E	3.78	3.98	0.149	0.157
E1	5.8	6.2	0.228	0.244
L	0.4	0.8	0.016	0.031
b	0.355	0.455	0.014	0.018
e	1.27 TYP		0.05 TYP	
c	0.153	0.253	0.006	0.001
θ	2°	6°	2°	6°

Tape & Reel Information

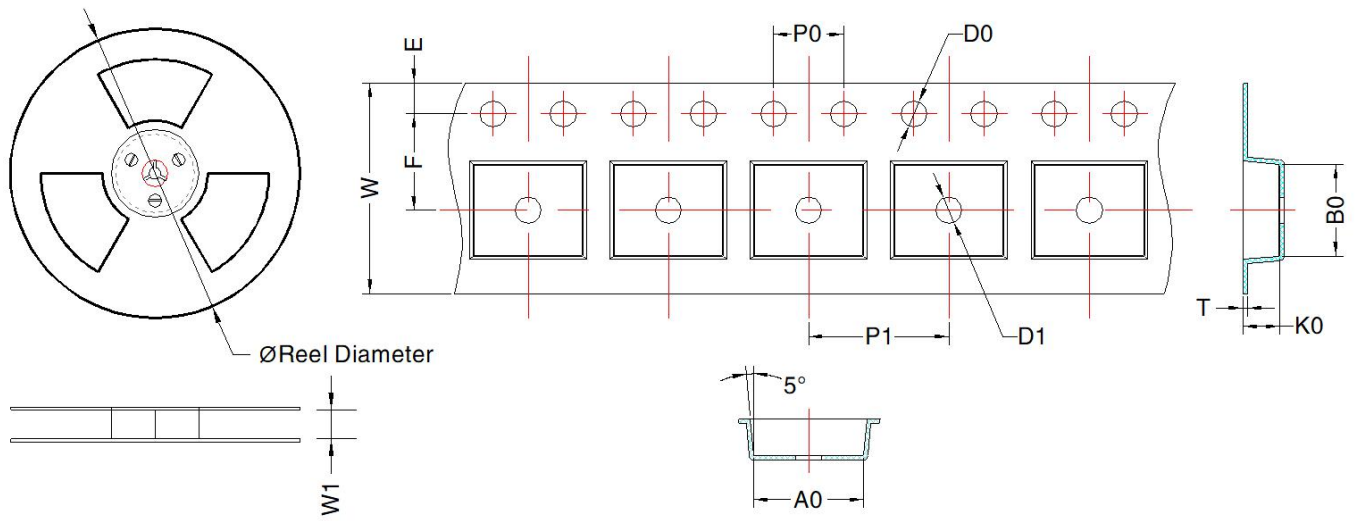

The orientation of IC in tape

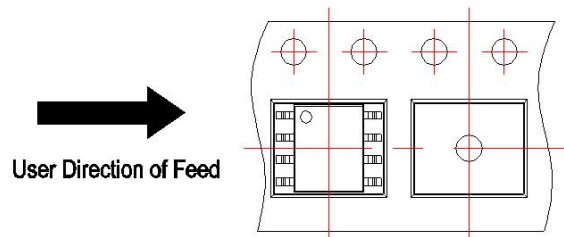

Device	Package Type	MPQ	Reel Diameter (mm)	Reel Width W1 (mm)	A0 (mm)	B0 (mm)	K0 (mm)	T (mm)	W (mm)	E (mm)	F (mm)	P1 (mm)	P0 (mm)	D0 (mm)	D1 (mm)
SCM3402ASI	SOP-8	2500	330.0	12.4	6.4±0.1	5.3±0.1	2.1±0.1	0.25±0.03	12.0±0.1	1.75±0.1	5.5±0.1	8±0.1	4±0.1	1.5±0.1	1.5±0.1

MORNSUN Guangzhou Science & Technology Co., Ltd.

Address: No. 5, Kehui St. 1, Kehui Development Center, Science Ave., Guangzhou Science City, Huangpu District, Guangzhou, P. R. China
 Tel: 86-20-38601850 Fax: 86-20-38601272 E-mail: info@mornsun.cn www.mornsun-power.com