

WT6632F
(Standard Code Version)
USB Power Delivery Controller

Data Sheet

Rev. 1.0

September 2016

Copyright Notice

This data sheet is copyrighted by Weltrend Semiconductor, Inc. Do not reproduce, transform to any other format, or send/transmit any part of this documentation without the express written permission of Weltrend Semiconductor, Inc.

Disclaimers

Right to make change –

This document provides technical information for user. Weltrend Semiconductor, Inc. reserves the right to make change without further notice to any products herein.

Table of Contents

1. GENERAL DESCRIPTION.....	2
1.1 Features.....	2
1.2 Applications.....	2
2. ORDERING INFORMATION.....	3
3. SELECTION GUIDE	3
4. PIN ASSIGNMENT	4
4.1 Package.....	4
4.2 Pin Description.....	5
5. ELECTRICAL CHARACTERISTICS	6
5.1 Absolute Maximum Ratings	6
5.2 Thermal Characteristics.....	6
5.3 Recommended Operating Conditions	6
6. EXAMPLE OF APPLICATION	7
6.1 Adapter/Charger	7
6.2 Adapter for 65W	8
7. PACKAGE DIMENSIONS	9
8. REVISION HISTORY	10

1. General Description

The WT6632F (Standard Code Version) is a highly integrated USB Power Delivery (PD) controller built-in with Weltrend's proprietary standard codes that supports USB PD 2.0 specifications and Qualcomm[®] Quick Charge[™] 3.0 technology designed for USB Type-C charging applications such as travel adapters, chargers, etc. It minimizes external components by integrating USB PD baseband PHY, Type-C detection, shunt regulator, voltage and current monitors, and control circuits of blocking MOSFET to allow small form factor and low BOM cost. It supports wide operation range from 4V to 30V without the need of an external LDO.

1.1 Features

- USB Type-C charge-only Downstream Facing Port (Source)
- USB Power Delivery Rev.2.0 baseband communication
- USB Battery Charging specification, revision 1.2 (BC 1.2) Dedicated Charging Port (DCP)
- Quick Charge 2.0 class A, 5V/9V/12V, High Voltage DCP (HVDCP)
- Quick Charge 3.0 class A, 3.6V to 12V, HVDCP
- Built-in shunt regulator for Constant Voltage (CV) and Constant Current (CC)
 - ◆ provides USB PD 5V, 9V, 12V, 15V and 20V source power outputs
 - ◆ provide high-resolution voltage steps according to Quick Charge 3.0 requirements
 - ◆ compliant with Quick Charge 3.0 power profile design recommendations
- Over Voltage Protection (OVP)
- Over Current Protection (OCP)
- Low side voltage output current shunt monitor
- 10-bit ADC for voltage and current monitoring
- External blocking MOSFET control
- Built-in discharge MOS
- Internal RC oscillator
- Internal VDD regulator
- General Purpose I/Os (GPIOs)
- Support power saving mode
- Operating voltage range: 3V ~ 30V
- Operating temperature range: -20°C ~ +105°C
- Package: 14-pin SOP

1.2 Applications

- USB Type-C travel adapters and chargers

2. Ordering Information

Item	Part Number	Application	Package Outline	Package Type	Tape/Reel
18W	WT6632F-SG14BWT-S18	Adapter/Charger	150 mil	14-pin SOP	3K
30W	WT6632F-SG14BWT-S30				
45W	WT6632F-SG14BWT-S45				
65W	WT6632F-SG14BWT-S65				

3. Selection Guide

Support power “18W to 65W” specification as bellow:

- 5V, 9V and 12V mode: Support USB Power Delivery Rev.2.0 and Quick Charge 3.0
- 15V and 20V mode: Only support Power Delivery Rev.2.0
- Protected Mode: (1) OCP: Auto Re-start
(2) OVP: Latch

Adapter and Charger

Model	5V			9V			12V			15V			20V		
	I (A)	OCP (A)	OVP (V)	I (A)	OCP (A)	OVP (V)	I (A)	OCP (A)	OVP (V)	I (A)	OCP (A)	OVP (V)	I (A)	OCP (A)	OVP (V)
18W	3	3.6	6.5	2	2.4	10.8	1.5	1.9	14.4	1.2	1.5	18	0.9	1.2	24
30W	3	3.6	6.5	3	3.6	10.8	2.5	3	14.4	2	2.4	18	1.5	2	24
45W	3	3.6	6.5	3	3.6	10.8	3	3.6	14.4	3	3.6	18	2.25	2.6	24
65W	3	3.6	6.5	3	3.6	10.8	3	3.6	14.4	3	3.6	18	3.25	3.9	24

4. Pin Assignment

4.1 Package

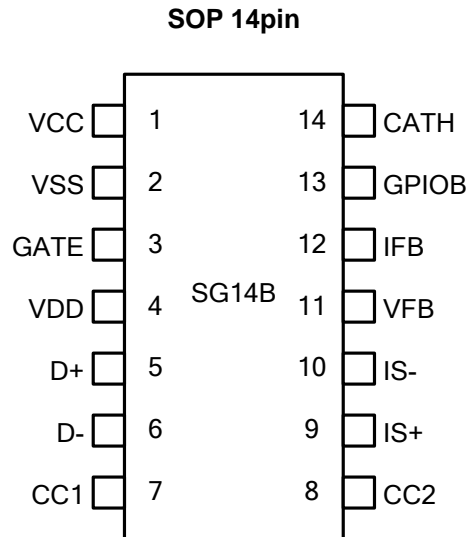

4.2 Pin Description

Pin No. SOP 14B	Name	Function	I/O Voltage	Type		Description
				Input	Output	
1	VCC	VCC	HV	-	-	Positive power supply
2	VSS	VSS	-	-	-	Ground
3	GATE	GATE	HV	-	PP	Blocking MOS Control
4	VDD	VDD	LV	-	AN	4.8V regulator
5	D+	D+	HV	AN	-	D+ for B.C. with USB device side
6	D-	D-	LV	AN	-	D- for B.C. with USB device side
7	CC1	CC1	HV	CC	PP	USB Type-C Configuration Channel
8	CC2	CC2	HV	CC	PP	USB Type-C Configuration Channel
9	IS+	IS+	LV	AN	-	Positive input of current sensing amplifier.
10	IS-	IS-	LV	AN	-	Negative input of current sensing amplifier.
11	VFB	VFB	LV	AN	-	Feedback of shunt regulator
12	IFB	IFB	HV	AN	-	Feedback of shunt regulator
13	GPIOB	GPIOB	HV	TTL	OD	General purpose I/O.
14	CATH	CATH	HV	-	AN	Cathode of shunt regulator

Legend: HV = High Voltage (max. 30V), LV = Low voltage (max. 5.5V), OD = Open Drain, PP = Push Pull, AN = analog, TTL = TTL compatible input, CC = USB PD baseband input

5. Electrical Characteristics

5.1 Absolute Maximum Ratings

Parameter		Min.	Max.	Units
Supply voltage VCC pin		-0.3	30	V
Input voltage	D+, GATE, IFB, CC1, CC2, CATH, GPIOB	-0.3	VCC + 0.3 (max. 30V)	V
	D-, IS+, IS-, VFB	-0.3	5.5	V
Output voltage	D+, GATE, IFB, CATH, GPIOB	-0.3	VCC + 0.3 (max. 30V)	V
	D-, IS+, IS-, VFB, VDD	-0.3	5.5	V
Operating temperature		-40	125	°C
Storage temperature		-55	150	°C

NOTE: Maximum ratings applied to the device are individual stress limit value. Stresses above those listed may cause permanent damage and reliability may be affected.

5.2 Thermal Characteristics

Parameter		Condition	Min.	Typ.	Max.	Units
θ_{JA}	Thermal Resistance (Junction to Air)	SOP 14 pin		90		°C/W
θ_{JC}	Thermal Resistance (Junction to Case)	SOP 14 pin		37		°C/W
T_{JMAX}	Maximum Junction Temperature	SOP 14 pin		125		°C

5.3 Recommended Operating Conditions

Parameter		Condition	Min.	Typ.	Max.	Units
V_{CC_OPR}	Operating voltage		3		30	V
T_{OPR}	Operating Temperature		-20		105	°C

6. Example of Application

6.1 Adapter/Charger

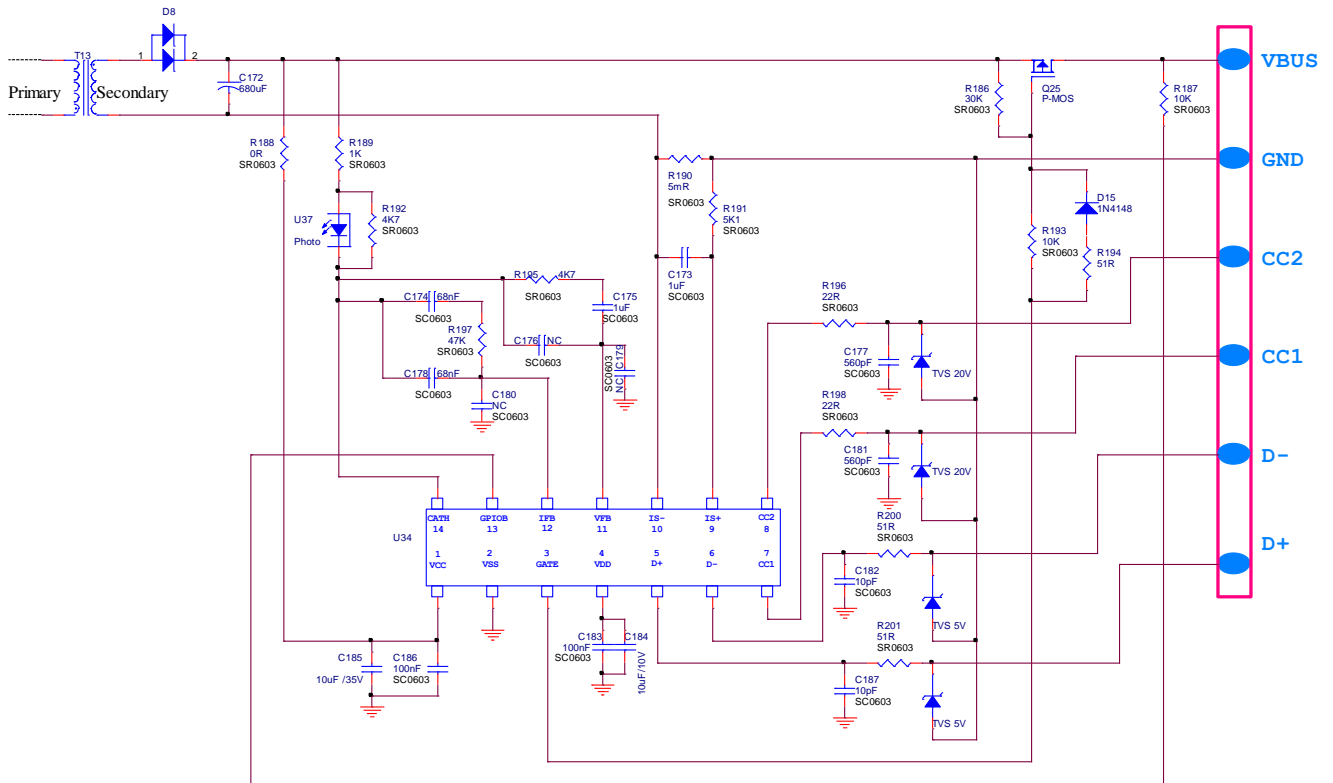

6.2 Adapter for 65W

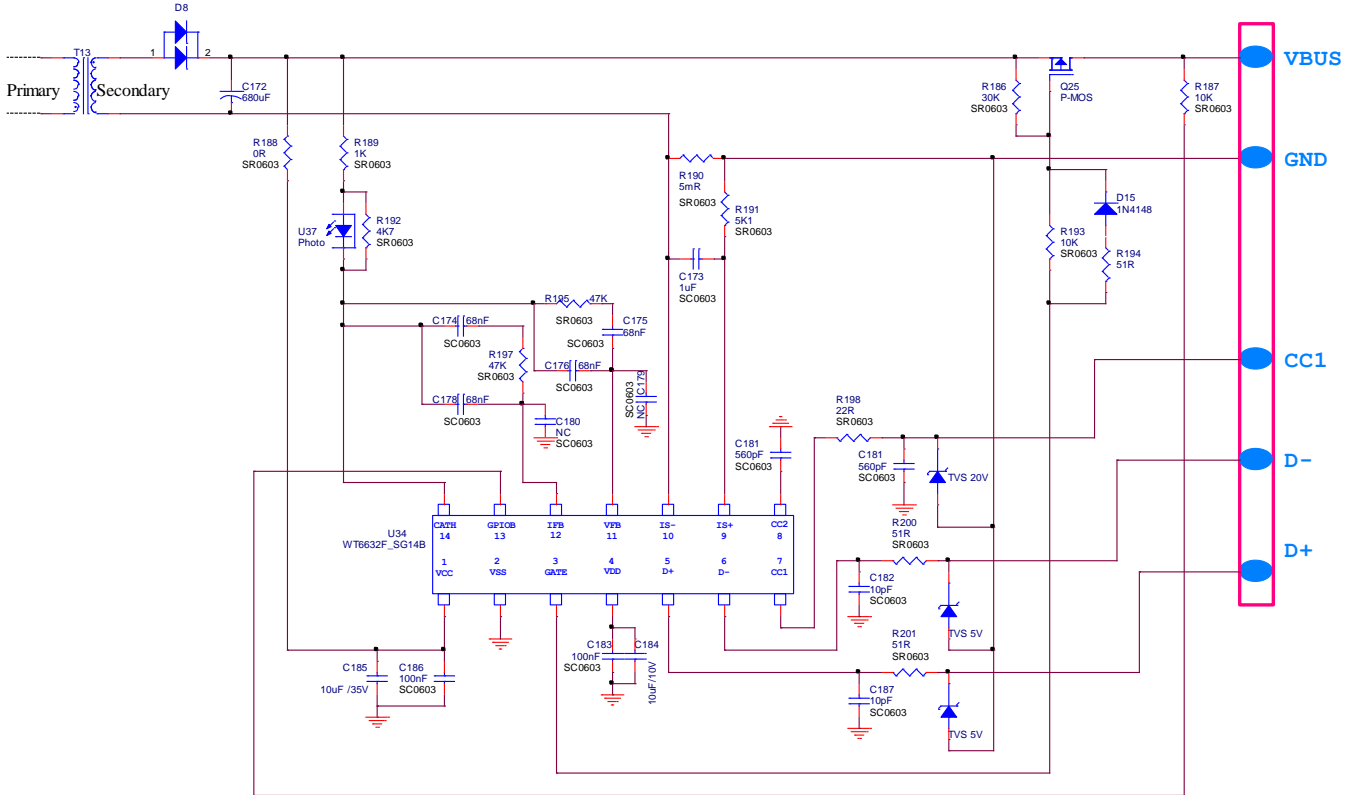

7. Package Dimensions

14-pin SOP

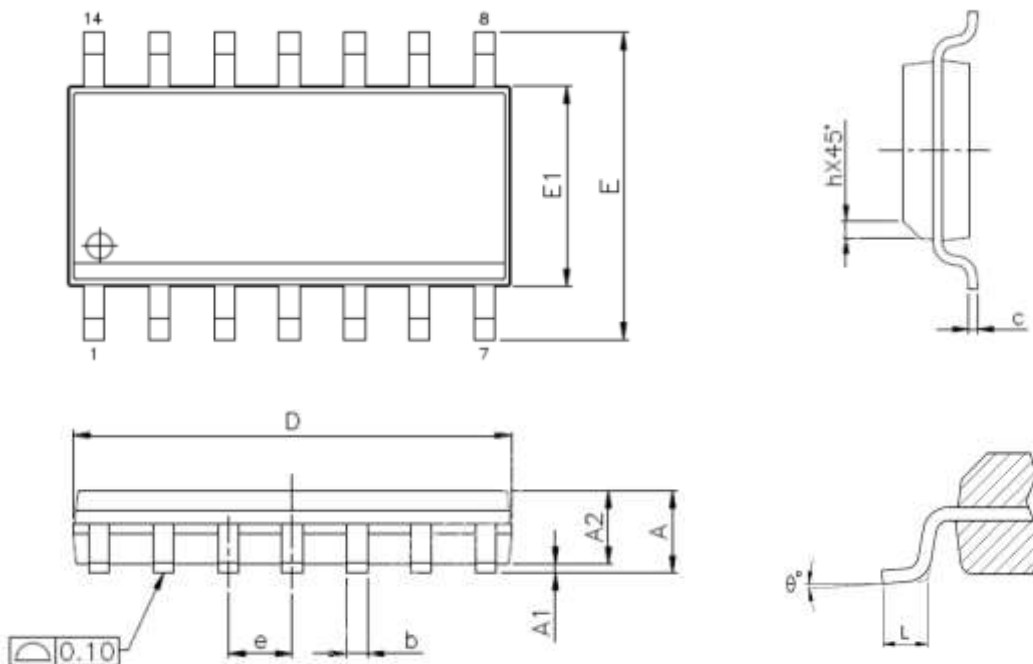

All dimensions shown in mm

SYMBOL	MIN.	MAX.
A	-	1.75
A1	0.10	0.25
A2	1.25	-
b	0.31	0.51
c	0.10	0.25
D	8.53	8.74
E	6.00 BSC	
E1	3.81	3.99
e	1.27 BSC	
L	0.40	1.27
h	0.25	0.50
θ°	0	8

NOTES:

1. Dimensions "D" does not include mold flash, protrusions or gate burrs mold flash. Protrusions or gate burrs shall not exceed 0.15mm.
2. Dimensions "E1" does not include inter-lead flash, or protrusions. Inter-lead flash and protrusions shall not exceed 0.25mm per side.

8. Revision History

Version	History	Date
1.0	Initial release	2016/09/30



CLASS A 3.6V to 12V

Qualcomm Quick Charge is a product of Qualcomm Technologies, Inc.

Qualcomm is a trademark of Qualcomm Incorporated, registered in the United States and other countries.

Quick Charge is a trademark of Qualcomm Incorporated. All Qualcomm Incorporated trademarks are used with permission.