



1、概述

74HC164D是高速 CMOS 电路，管脚与低功耗肖特基 TTL（LSTTL）系列兼容。74HC164D是8位的串入并出、边沿触发的移位寄存器，串入数据由 DSA、DSB 输入，在每个时钟 CP 的上升沿数据向右移一位，数据由 DSA 和 DSB 相与而成，且在上升沿到来之前已满足了建立时间。低电平有效的

复位信号将直接把寄存器清零而输出为低。其主要特点如下：

- 较宽的工作电压：2~6V
- 相与的串行输入，直接的清零信号
- 输出能驱动 10 个 LSTTL 负载
- 封装型式：DIP14 / SOP14/TSSOP14

2、功能框图及引脚说明

2.1、功能框图

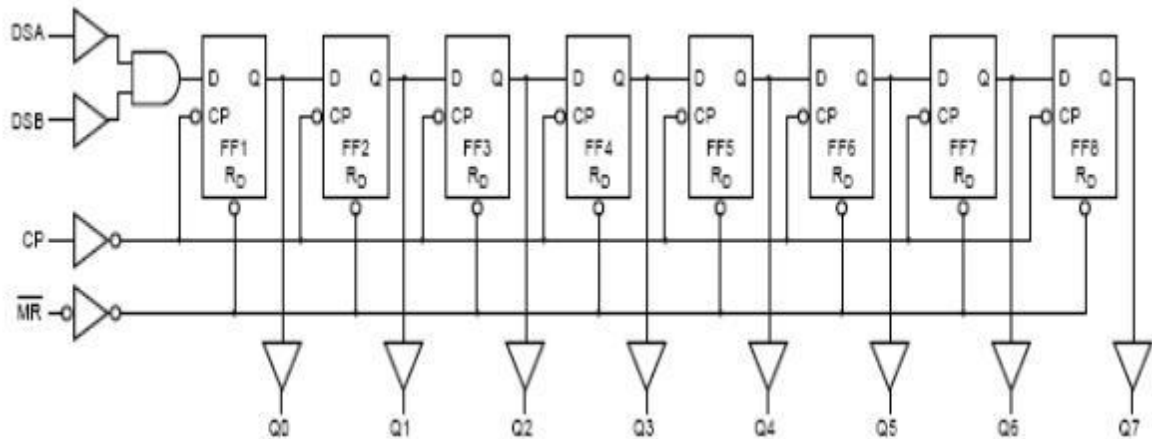

2.2、引脚排列图

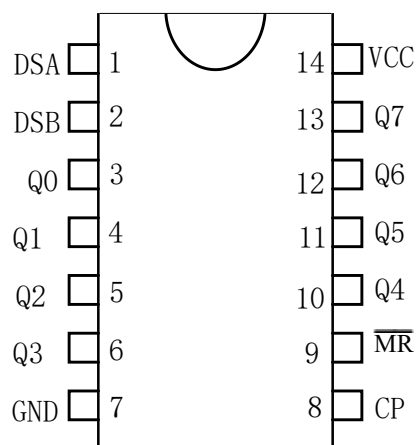



2.3、引脚说明及结构原理图

管脚号	符号	说明	管脚号	符号	说明
1	DSA	数据输入	8	CP	时钟输入(低到高, 边沿触发)
2	DSB	数据输入	9	\overline{MR}	复位输入(低有效)
3	Q0	输出	10	Q4	输出
4	Q1	输出	11	Q5	输出
5	Q2	输出	12	Q6	输出
6	Q3	输出	13	Q7	输出
7	GND	地(0V)	14	VCC	电源电压

2.4、功能说明

工作模式	输入				输出	
	\overline{MR}	CP	DSA	DSB	Q0	Q1~Q7
Reset(clear)	L	X	X	X	L	L~L
Shift	H	t	l	l	L	Q0~Q6
	H	t	l	h	L	Q0~Q6
	H	t	h	l	L	Q0~Q6
	H	t	h	h	H	Q0~Q6

注: H: 高电平

h: 时钟上升沿前建立起来的高电平电压

L: 低电平

l: 时钟上升沿前建立起来的低电平电压

q: 对应于时钟上升沿时, 前面一个寄存器的状态

t: 时钟上升沿

3、电特性

3.1、极限参数 除非另有规定, $T_{amb}=25^{\circ}\text{C}$

参数名称	符号	条件	最小值	最大值	单位
电源电压	V_{CC}		-0.5	+7	V
输入钳位电流	I_{IK}	$V_I < -0.5\text{V}$ 或 $V_I > V_{CC} + 0.5\text{V}$		± 20	mA
输出钳位电流	I_{OK}	$V_O < -0.5\text{V}$ 或 $V_O > V_{CC} + 0.5\text{V}$		± 20	mA
输出电流	I_O	$V_O = -0.5\text{V} \sim V_{CC} + 0.5\text{V}$		± 25	mA
VCC 或 GND 电流	I_{CC}, I_{GND}			± 50	mA
贮存温度	T_{STG}		-65	+150	$^{\circ}\text{C}$
焊接温度	T_L	10 秒	DIP 封装	245	C
			SOP 封装	250	



3.2、推荐使用条件

参数	符号	条件	最小	典型	最大	单位
电源电压	V_{CC}		2.0	5.0	6.0	V
输入电压	V_I		0	-	V_{CC}	V
输出电压	V_O		0	-	V_{CC}	V
输入上升、下降时间	tr,tf	$V_{CC}=2.0V$	-	-	1000	ns
		$V_{CC}=4.5V$	-	6.0	500	ns
		$V_{CC}=6.0V$	-	-	400	ns
工作温度	T_{amb}		-40	-	+85	°C

3.3、电气特性

除非另有规定， $T_{amb}=25^{\circ}C$

参数名称	符号	测试条件	规范值			单位
			最小	典型	最大	
直流参数						
高电平输入电压	V_{IH}	$V_{CC}=2.0V$	1.5	-	-	V
		$V_{CC}=4.5V$	3.15	-	-	V
		$V_{CC}=6.0V$	4.2	-	-	V
低电平输入电压	V_{IL}	$V_{CC}=2.0V$	-	-	0.5	V
		$V_{CC}=4.5V$	-	-	1.35	V
		$V_{CC}=6.0V$	-	-	1.8	V
高电平输出电压	V_{OH}	$V_I=V_{IH}$ 或 V_{IL}				
		$I_O=-20\mu A$; $V_{CC}=2.0V$	1.9	2.0	-	V
		$I_O=-20\mu A$; $V_{CC}=4.5V$	4.4	4.5	-	V
		$I_O=-20\mu A$; $V_{CC}=6.0V$	5.9	6.0	-	V
		$I_O=-4mA$; $V_{CC}=4.5V$	3.98	4.32	-	V
		$I_O=-5.2mA$; $V_{CC}=6.0V$	5.48	5.81	-	V
低电平输出电压	V_{OL}	$V_I=V_{IH}$ 或 V_{IL}				
		$I_O=20\mu A$; $V_{CC}=2.0V$	-	0	0.1	V
		$I_O=20\mu A$; $V_{CC}=4.5V$	-	0	0.1	V
		$I_O=20\mu A$; $V_{CC}=6.0V$	-	0	0.1	V
		$I_O=4mA$; $V_{CC}=4.5V$	-	0.19	0.26	V
		$I_O=5.2mA$; $V_{CC}=6.0V$	-	0.21	0.26	V
静态电流	I_{CC}	$V_{CC}=6.0V$; $I_O=0A$; $V_I=V_{CC}$ 或GND	-	3.9	8	μA
输入电容	C_i		-	3.5	-	pF



参数名称		符号	测试条件	规范值			单位
				最小	典型	最大	
交流参数							
传输延时	负载电容						
Cp ~ Qn	CL=50p	tPHL, tPLH	见图 1				
			VCC=2.0V	-	41	170	ns
			VCC=4.5V	-	15	34	ns
			VCC=6.0V	-	12	29	ns
\overline{MR} ~ Qn	CL=50p	tPHL, tPLH	见图 2				
			VCC=2.0V	-	39	140	ns
			VCC=4.5V	-	14	28	ns
			VCC=6.0V	-	11	24	ns
输出传输时间	CL=50p	tTHL, tTLH	见图 1				
			VCC=2.0V	-	19	75	ns
			VCC=4.5V	-	7	15	ns
			VCC=6.0V	-	6	13	ns
时钟脉宽(低电平或高电平)		tw	见图 1				
			VCC=2.0V	80	-	-	ns
			VCC=4.5V	16	-	-	ns
			VCC=6.0V	14	-	-	ns
主复位时钟脉宽(低电平)		tw	见图 2				
			VCC=2.0V	60	-	-	ns
			VCC=4.5V	12	-	-	ns
			VCC=6.0V	10	-	-	ns
从 \overline{MR} ~ CP 的响应时间		trem	见图 2				
			VCC=2.0V	60	-	-	ns
			VCC=4.5V	12	-	-	ns
			VCC=6.0V	10	-	-	ns
从 DSA、DSB ~ CP 的建立时间		tsu	见图 3				
			VCC=2.0V	60	-	-	ns
			VCC=4.5V	12	-	-	ns
			VCC=6.0V	10	-	-	ns
从 DSA、DSB ~ CP 的保持时间		th	见图 3				
			VCC=2.0V	6	-	-	ns
			VCC=4.5V	6	-	-	ns
			VCC=6.0V	6	-	-	ns



最大时钟频率	f_{max}	见图 1				
		$V_{CC}=2.0V$	6	23	-	MHz
		$V_{CC}=4.5V$	30	71	-	MHz
		$V_{CC}=6.0V$	35	85	-	MHz

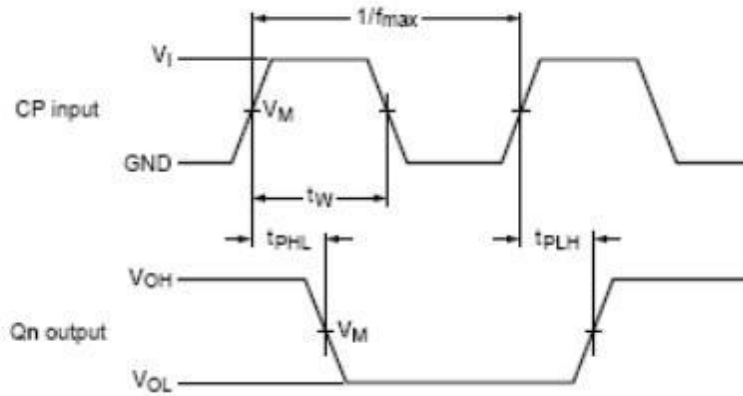

$V_M=50\%$; $V_I=GND \sim V_{CC}$

图 1.时钟(CP)到输出端(Qn)的传输延时、时钟脉宽、输出传输时间和最大时钟频率

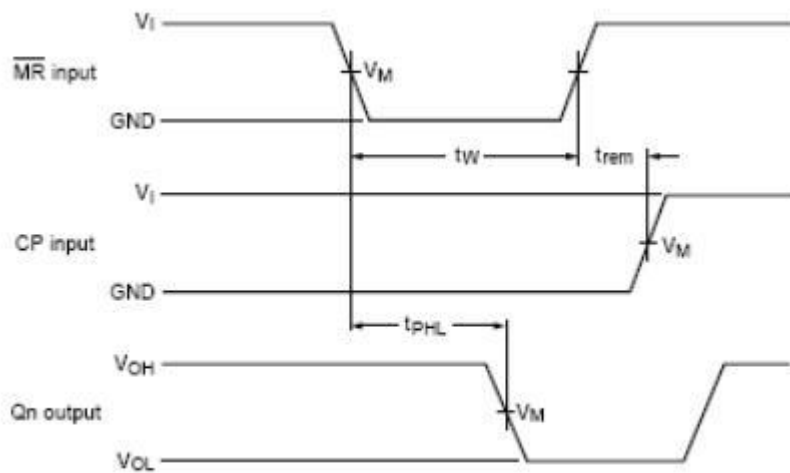

$V_M=50\%$; $V_I=GND \sim V_{CC}$

图 2.主复位(\overline{MR})脉宽,主复位到输出端(Qn)的传输延时、主复位结束到时钟(CP)的响应时间

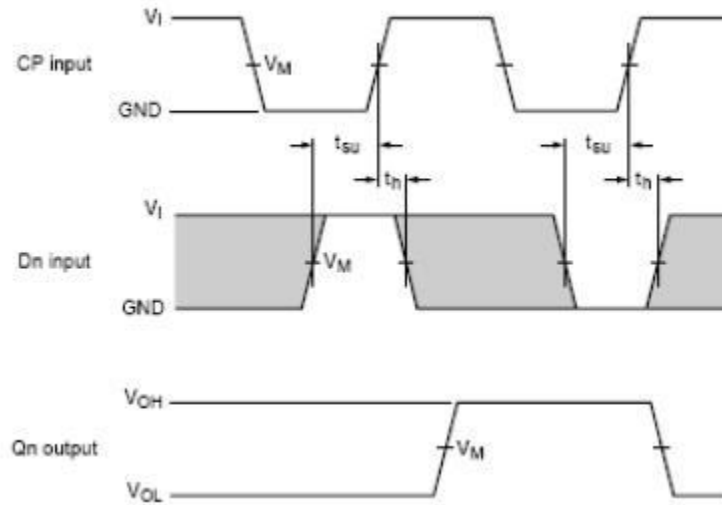

$$V_M=50\%; V_I=GND \sim VCC$$

图 3. Dn 输入前的数据建立时间和保持时间



图 4.测试开关时间的负载电路

注：RT：终端电阻须与信号发生器的输出阻抗匹配

CL：负载电容须包括夹具有探针电容



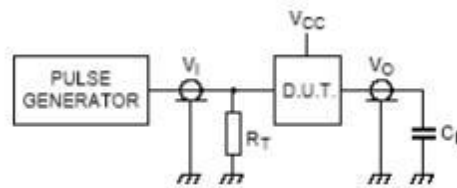
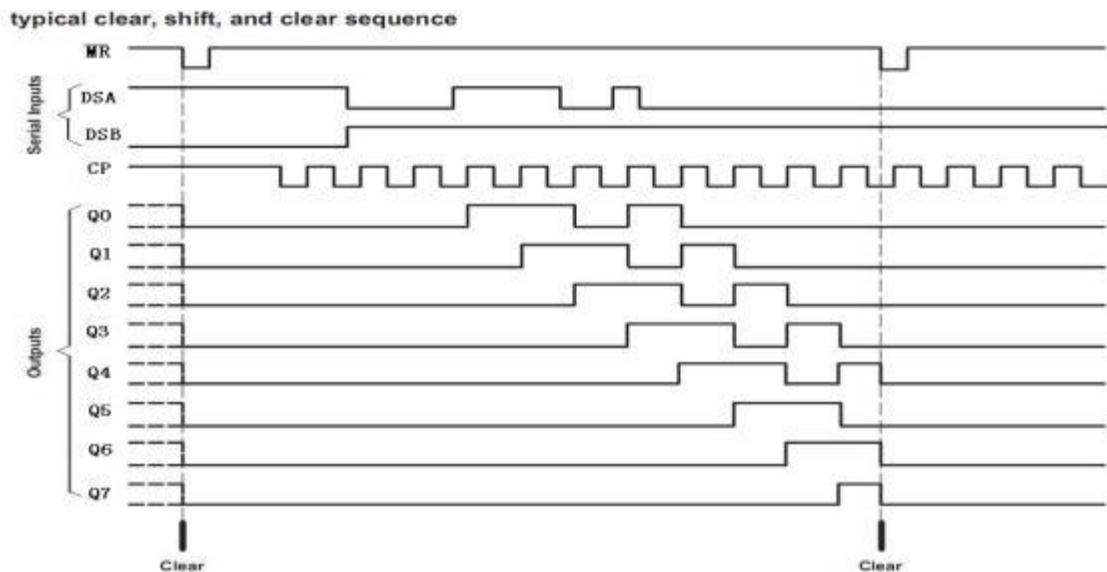

4、封装尺寸与外形图

4.1、DIP14 外形图与封装尺寸

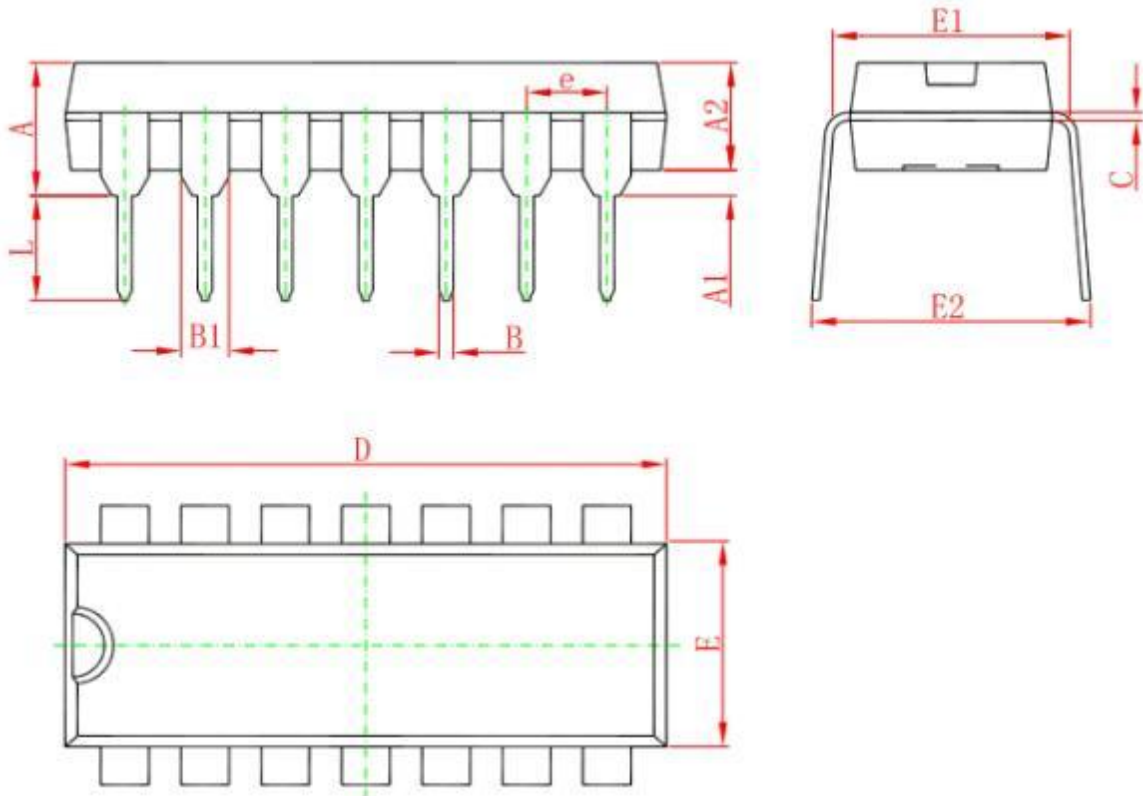

Symbol	Dimensions In Millimeters		Dimensions In Inches	
	Min	Max	Min	Max
A	3.710	4.310	0.146	0.170
A1	0.510		0.020	
A2	3.200	3.600	0.126	0.142
B	0.380	0.570	0.015	0.022
B1	1.524 (BSC)		0.060 (BSC)	
C	0.204	0.360	0.008	0.014
D	18.800	19.200	0.740	0.756
E	6.200	6.600	0.244	0.260
E1	7.320	7.920	0.288	0.312
e	2.540 (BSC)		0.100 (BSC)	
L	3.000	3.600	0.118	0.142
E2	8.400	9.000	0.331	0.354



4.2、SOP14 外形图与封装尺寸

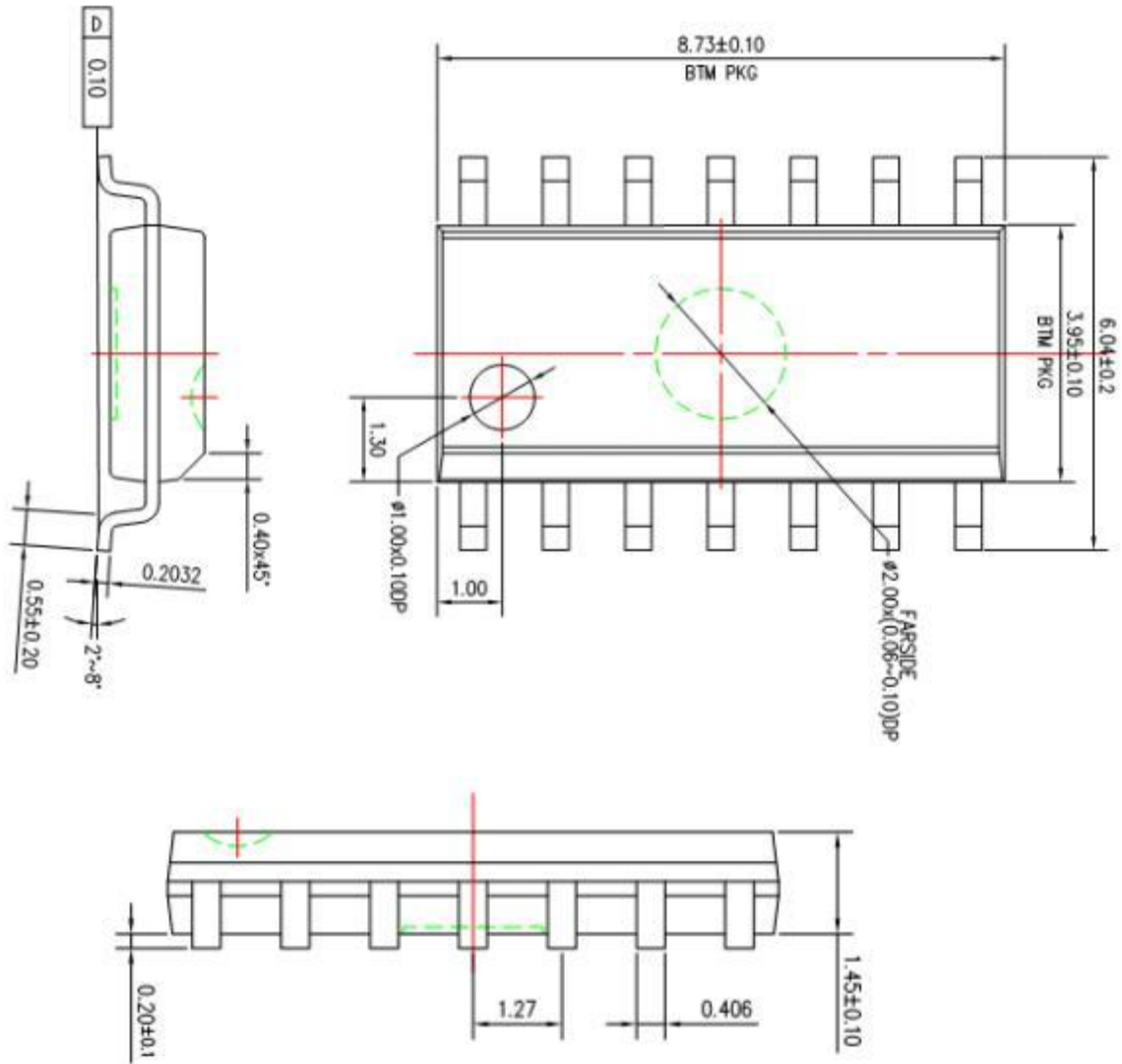



4.3、TSSOP14 外形图与封装尺寸

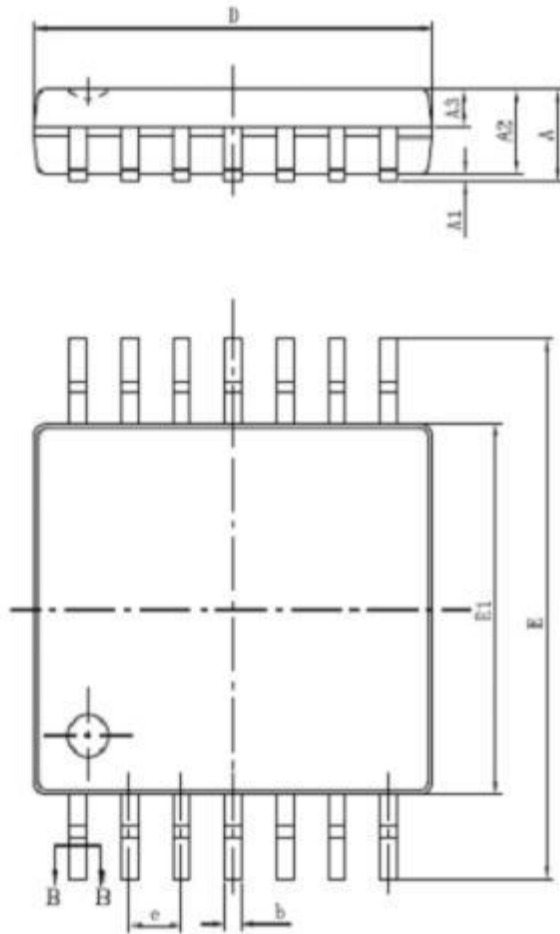

SYMBOL	MILLIMETER	
	MIN	MAX
A	—	1.20
A1	0.05	0.15
A2	0.90	1.05
A3	0.39	0.49
b	0.20	0.30
b1	0.19	0.25
c	0.13	0.19
c1	0.12	0.14
D	4.86	5.06
E1	4.30	4.50
E	6.20	6.60
e	0.65BSC	
L	0.45	0.75
L1	1.00BSC	
θ	0	8°

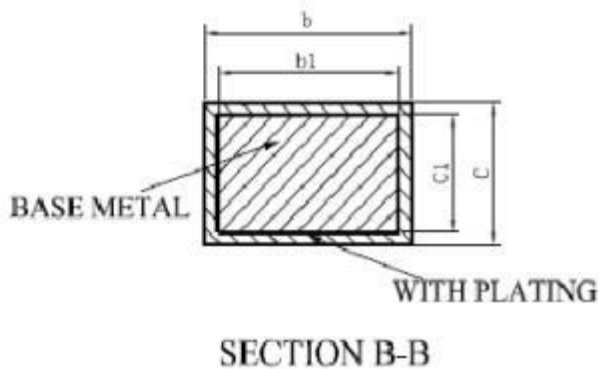
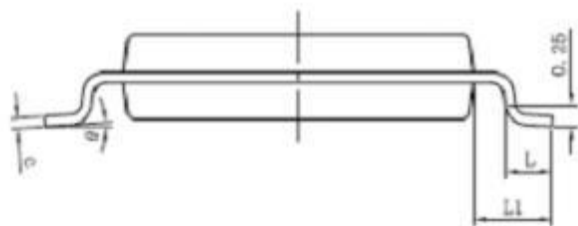



5、声明及注意事项：

5.1、产品中有毒有害物质或元素的名称及含量

部件名称	有毒有害物质或元素					
	铅 (Pb)	汞 (Hg)	镉 (Cd)	六价铬 (Cr(VI))	多溴联苯 (PBBs)	多溴联苯醚 (PBDEs)
引线框	○	○	○	○	○	○
塑封树脂	○	○	○	○	○	○
芯片	○	○	○	○	○	○
内引线	○	○	○	○	○	○
装片胶	○	○	○	○	○	○
说明	○：表示该有毒有害物质或元素的含量在 SJ/T11363-2006 标准的检出限以下。 ×：表示该有毒有害物质或元素的含量超出 SJ/T11363-2006 标准的限量要求。					

5.2 注意

在使用本产品之前建议仔细阅读本资料；

本资料中的信息如有变化，恕不另行通知；

本资料仅供参考，本公司不承担任何由此而引起的任何损失；

本公司也不承担任何在使用过程中引起的侵犯第三方专利或其它权利的责任。



Attention

- Any and all HUA XUAN YANG ELECTRONICS products described or contained herein do not have specifications that can handle applications that require extremely high levels of reliability, such as life-support systems, aircraft's control systems, or other applications whose failure can be reasonably expected to result in serious physical and/or material damage. Consult with your HUA XUAN YANG ELECTRONICS representative nearest you before using any HUA XUAN YANG ELECTRONICS products described or contained herein in such applications.
- HUA XUAN YANG ELECTRONICS assumes no responsibility for equipment failures that result from using products at values that exceed, even momentarily, rated values (such as maximum ratings, operating condition ranges, or other parameters) listed in products specifications of any and all HUA XUAN YANG ELECTRONICS products described or contained herein.
- Specifications of any and all HUA XUAN YANG ELECTRONICS products described or contained herein stipulate the performance, characteristics, and functions of the described products in the independent state, and are not guarantees of the performance, characteristics, and functions of the described products as mounted in the customer's products or equipment. To verify symptoms and states that cannot be evaluated in an independent device, the customer should always evaluate and test devices mounted in the customer's products or equipment.
- HUA XUAN YANG ELECTRONICS CO.,LTD. strives to supply high-quality high-reliability products. However, any and all semiconductor products fail with some probability. It is possible that these probabilistic failures could give rise to accidents or events that could endanger human lives, that could give rise to smoke or fire, or that could cause damage to other property. When designing equipment, adopt safety measures so that these kinds of accidents or events cannot occur. Such measures include but are not limited to protective circuits and error prevention circuits for safe design, redundant design, and structural design.
- In the event that any or all HUA XUAN YANG ELECTRONICS products(including technical data, services) described or contained herein are controlled under any of applicable local export control laws and regulations, such products must not be exported without obtaining the export license from the authorities concerned in accordance with the above law.
- No part of this publication may be reproduced or transmitted in any form or by any means, electronic or mechanical, including photocopying and recording, or any information storage or retrieval system, or otherwise, without the prior written permission of HUA XUAN YANG ELECTRONICS CO.,LTD.
- Information (including circuit diagrams and circuit parameters) herein is for example only ; it is not guaranteed for volume production. HUA XUAN YANG ELECTRONICS believes information herein is accurate and reliable, but no guarantees are made or implied regarding its use or any infringements of intellectual property rights or other rights of third parties.
- Any and all information described or contained herein are subject to change without notice due to product/technology improvement, etc. When designing equipment, refer to the "Delivery Specification" for the HUA XUAN YANG ELECTRONICS product that you intend to use.