

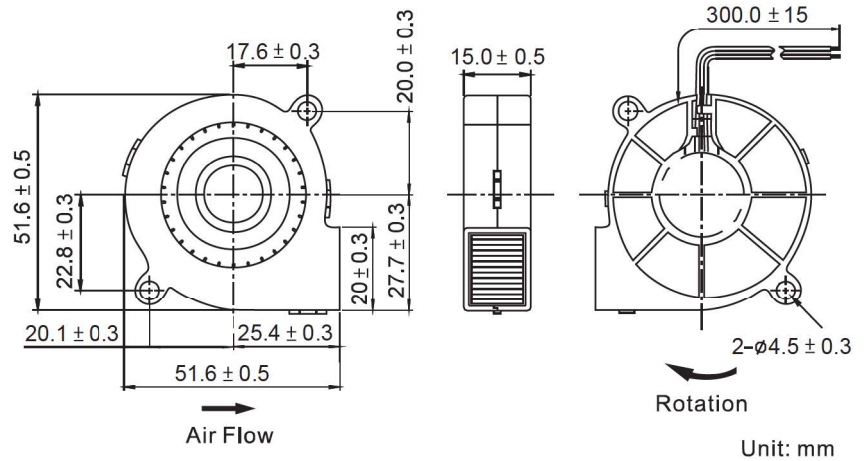

Dimensions Drawing



General Specification

- Frame and Impeller : Thermal Plastic , UL 94V-0
- Lead Wires : UL Type
(+) : Red (-) : Black
- Operation Temperature : -10°C~70°C
35%~85%RH
- Storage Temperature : -40°C~80°C
35%~85%RH
-

Performance Curves

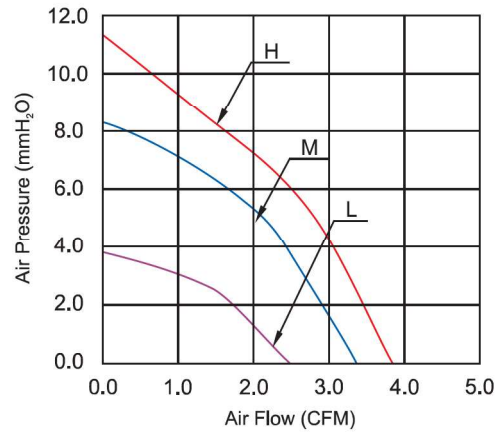

Listed Model	Bearing System	Rated Voltage	Operation Voltage	Rated Current	Rated Speed	Air Flow	Air Pressure	Noise Level	Available Features (Optional)				Weight	
		VDC	VDC	A	RPM	CFM	mmH ₂ O	dBA	Tachometer Output	Rotation Detector	Thermal Control	Pulse Width Modulation	g	
RBH5015S5	Sleeve	5	3.5~5.75	0.33	4,500	3.8	11.3	37	•	•			26	
RBM5015S5			3.5~5.75	0.22	4,000	3.4	7.4	35	•	•				
RBL5015S5			3.5~5.75	0.13	3,000	2.4	3.5	26	•	•				
RBH5015B5			Ball	3.5~5.75	0.33	4,500	3.8	11.3	37	•	•			
RBM5015B5				3.5~5.75	0.22	4,000	3.4	7.4	35	•	•			
RBL5015B5				3.5~5.75	0.13	3,000	2.4	3.5	26	•	•			
RBH5015S	Sleeve	12	6.0~13.8	0.14	5,000	4.4	11.5	41	•	•				
RBM5015S			6.0~13.8	0.09	4,000	3.4	7.4	35	•	•				
RBL5015S			8.0~13.8	0.05	3,000	2.4	3.5	26	•	•				
RBH5015B			Ball	6.0~13.8	0.14	5,000	4.4	11.5	41	•	•			
RBM5015B				6.0~13.8	0.09	4,000	3.4	7.4	35	•	•			
RBL5015B				8.0~13.8	0.05	3,000	2.4	3.5	26	•	•			
RBH5015S2	Sleeve	24	12.0~27.6	0.12	5,000	4.4	11.5	41	•	•				
RBM5015S2			12.0~27.6	0.08	4,000	3.4	7.4	35	•	•				
RBL5015S2			12.0~27.6	0.05	3,500	2.9	7.3	30	•	•				
RBH5015B2			Ball	12.0~27.6	0.12	5,000	4.4	11.5	41	•	•			
RBM5015B2				12.0~27.6	0.08	4,000	3.4	7.4	35	•	•			
RBL5015B2				12.0~27.6	0.05	3,500	2.9	7.3	30	•	•			

● All readings are typical values at rated voltage.
● Specifications are subjected to change without prior notice.