

REVISION RECORD				
REV	ECN	DESCRIPTION	DRFT	DATE

NOTES1:

UL Standard

- 1.Rated Voltage/Current : 300V / 15A
- 2.Torque Value : M2.5 , 3.54Lb.in
- 3.Wire Range : 22~14AWG

IEC Standard

- 1.Rated Voltage/Current : 250V / 17.5A
- 2.Torque Value : M2.5 , 0.4N.m
- 3.Wire Range : 0.2~1.5mm<sup>2</sup>

NOTES2:

- 1.Dimension shall be interpreted per ASME Y14.5-2009
- 2.Pitch : 5.0mm, Poles : N=02~22P
- 3.Stripping length : 5~6mm
- 4.Withstanding Voltage : AC2000V/1Min.
- 5.Operating temperature : -30°C~+120°C
- 6.Undimensioned Tolerances:

Pitch Range In mm		Nominal Dimension Range In mm						0.1/10
TO	Over TO	Over TO	TO	Over TO	Over TO	Over TO	0.1/10	
6	10	24	30	60	100	150	<	
±0.15	±0.20	±0.30	±0.30	±0.50	±0.70	±1.00	±1.30	±2'

7.RoHS Compliance

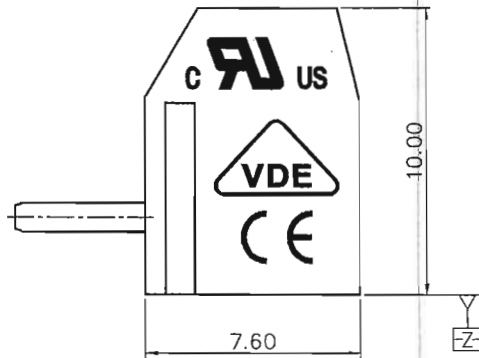
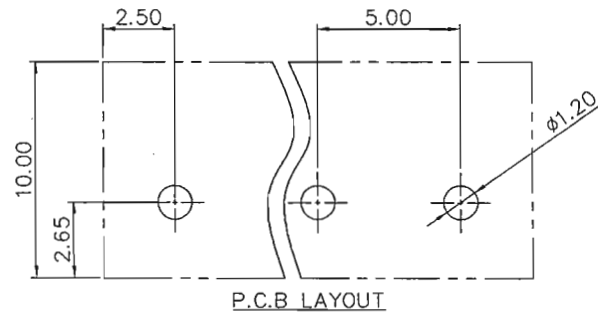
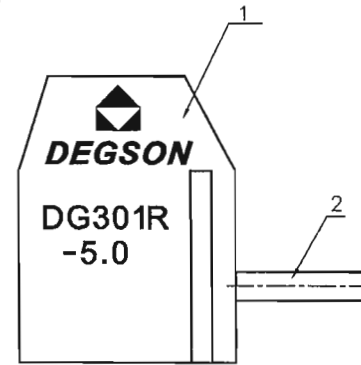
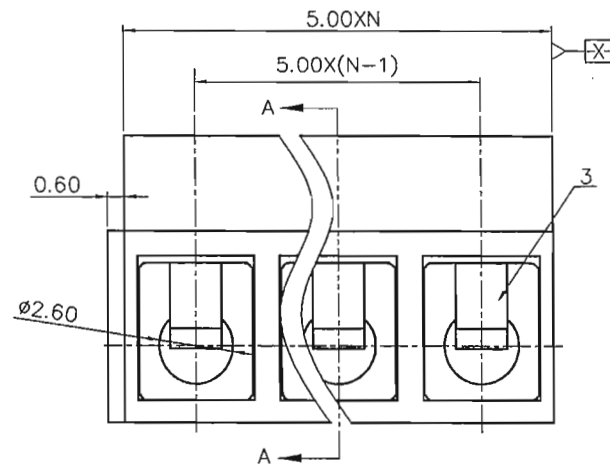
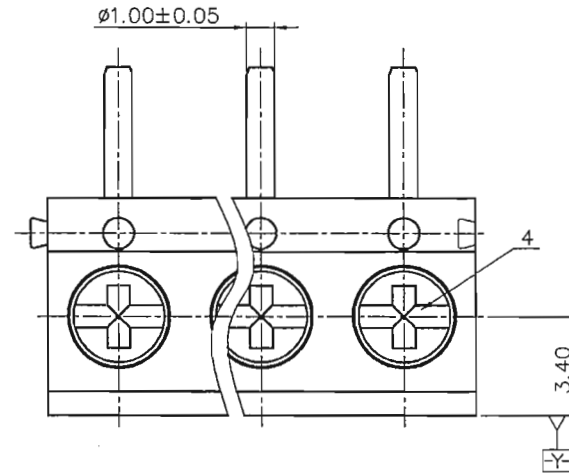

ITEM	NAME OF PART	MATERIAL	NOTES
4	SCREW	COPPER ALLOY	Zn Plated
3	SPRING	STAINLESS STEEL	
2	PIN	COPPER ALLOY	Sn Plated
1	HOUSING	PBT	UL94V-0

DETACHED LISTS	PART NO.: /	宁波高松电子有限公司 <b>DEGSON</b> <sup>®</sup> NINGBO DEGSON ELECTRICAL CO., LTD		
	APPD: <i>Aaron P/10-15</i>	NAME: DG301R-5.0-XXP-1Y-02A(H)		
	CHKD: <i>lea 9/8/15</i>	TITLE: CUSTOMER DRAWING		
	DRFT: Haoyh 03/20/06"	REV	TO	
 THIRD ANGLE PROJECTION		DRAWING NO.: DG301R-C03	SHEET	1/1
 DO NOT SCALE DRAWING		SCALE	1:1	