

日期/Date
 档案员
 Filing Clerk

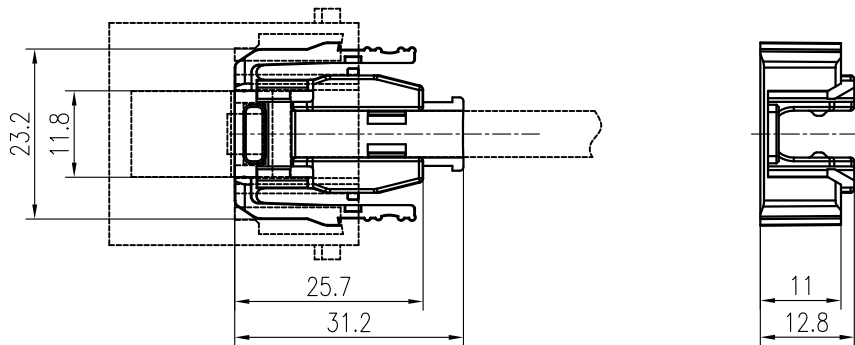

技术参数:

- 插芯:
- 插针数: 8
 - 额定电流: 1A
 - 额定电压: 50V
 - 额定脉冲电压: 0.8kV
 - 污染等级: 3
 - 依据UL的额定电压: <30V
 - 传输特性: 超6类可达500MHz
依据 ISO/IEC 24 702;
ISO/IEC 11 801
 - 传输速度: 10/100/1000Mbit/s
 - 绝缘阻抗: $> 10^{10}\Omega$
 - 材料: 聚碳酸酯
 - 颜色: RAL 7032 (浅灰色)
 - 温度范围: $-40^{\circ}\text{C} - +85^{\circ}\text{C}$
 - 依据UL 94的阻燃等级: V0
 - 可插拔次数: > 500

Technical specification:

- Inserts:
- No. of contact: 8
 - Rated current: 1A
 - Rated voltage: 50V
 - Rated impulse voltage: 0.8kV
 - Pollution degree: 3
 - Rated voltage acc.to UL: <30V
 - Transmission features: category 6/Class E
up to 500 MHz; acc.
to ISO/IEC 24 702;
ISO/IEC 11 801
 - Transmissiing rate: 10/100/1000Mbit/s
 - Insulation resistance: $> 10^{10}\Omega$
 - Material: polycarbonate
 - Colour: RAL 7032(light grey)
 - Temperature range: $-40^{\circ}\text{C} - +125^{\circ}\text{C}$
 - Flammability acc.to UL 94: V0
 - Mating cycles: > 500

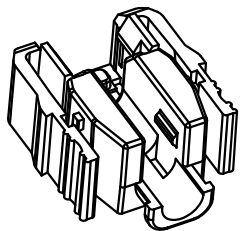

						表面处理 Finish	-		图号 Drawing No.	-
						材料 Material	-		产品代号 Part Code	HM-RJ45-APT/2
标记 Mark	处数 Number	变更描述/Description		签名 Signature	日期 Date				产品料号 Part No.	2290010000005
	姓名/Name	日期/Date		姓名/Name	日期/Date	比例 Scale	版本 REV.	重量 Weight	数量 Qty.	产品名称 Part Name
绘图 Drawn	BQ LUO	18.10.2010	标准化 Stand.	-	-	1:1	V1.0	3.8g	-	-
审核 Checked	P RAO	18.10.2010								
工艺 Process	-	-	批准 Approved	YY LIN	18.10.2010	All Dimensions in mm Original Size DIN A 4		厦门唯恩电气有限公司 XIAMEN WAIN ELECTRICAL CO.LTD		