

LITHIUM-ION RECHARGEABLE COIN CELL

SPECIFICATIONS

Model	: LIR2025H-1X1
Description	: Lithium-Ion Rechargeable Coin Cell
Nominal Capacity	: 40mAh (Min. 38) at 8mA discharge
Nominal Voltage	: 3.70 Volt
Cut-Off Voltage	: 2.75 Volt
Weight	: 2.6 gram
Life Duration	: Over 500 cycles at 0.2C mA discharge
Charge	Standard - CC at 8mA to 4.2V, then CV at 4.2V to current < 2mA Fast - CC at 40mA to 4.2V, then CV at 4.2V to current < 2mA
Max. Discharge Current	: 40mA
Temperature Environment	Standard Charge 0 degC to 45 degC Discharge -20 degC to 60 degC Storage -10 degC to 35 degC
Internal Impedance	: <900 mOhm (Full Charge, test at 1000Hz)
Appearance	No leakage, No remarkable scratch, flaws or discoloration. : No explosion under standard operating condition
Battery Maintenance	Battery stored and not used under room temperature for over 6 months have to be recharged.

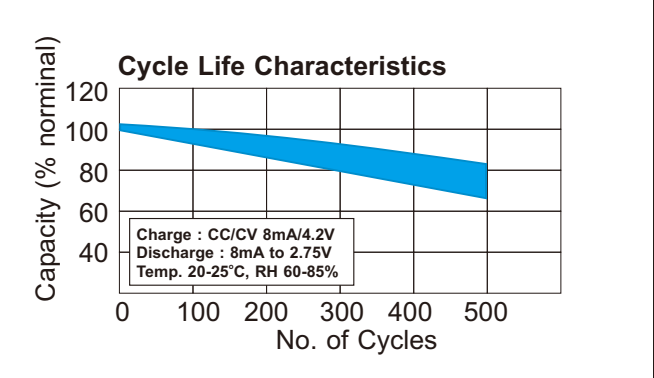
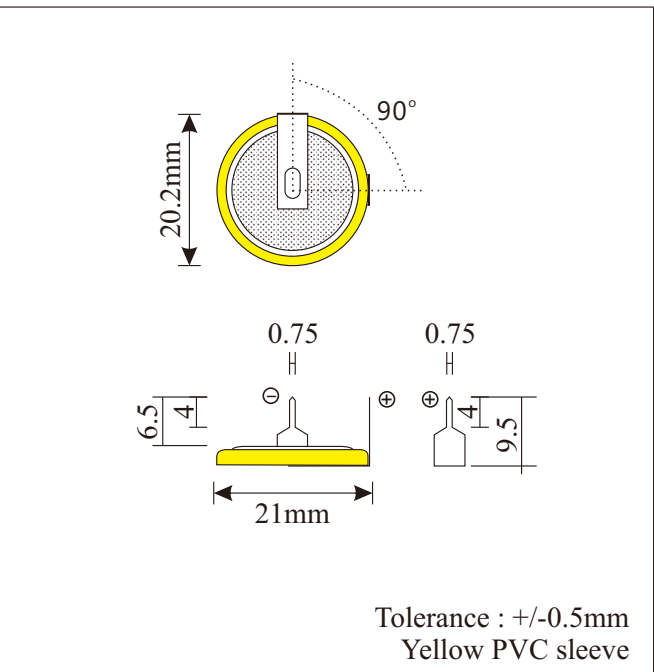
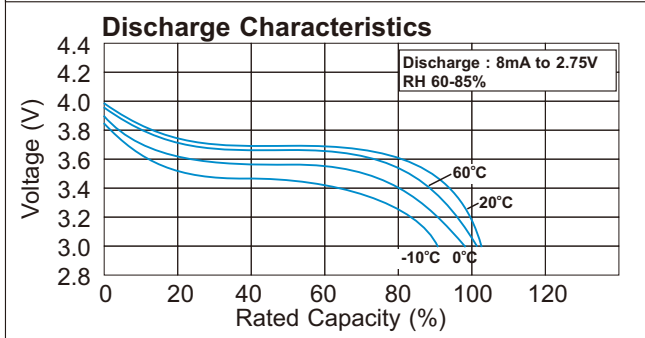
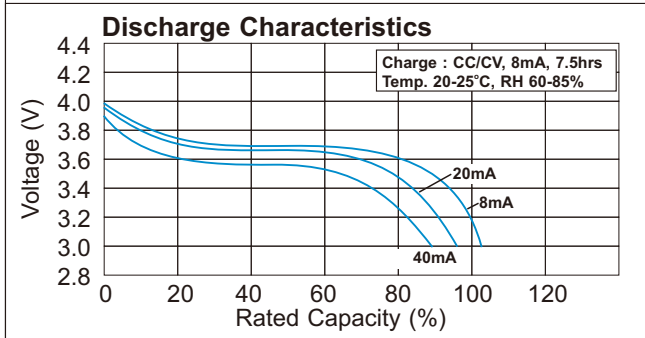
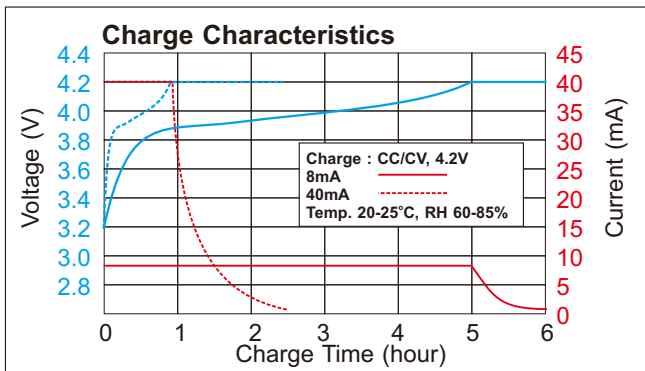

Information is for reference only and is not construed as warranties either expressed or implied, of future performance. Performance varies with time, discharge and storage condition.. 1 year limited guarantee against manufacturing defects. Other problem caused by misuse, mishandling of cell, or malfunction of equipment, is not under the warranty.

Model : LIR2025H-1X1
Version : 3.1

WELL LINK
INDUSTRIAL LIMITED

K522RA1

LITHIUM-ION RECHARGEABLE COIN CELL

PROPER USE AND HANDLING

Customer of lithium iron phosphate battery should employ appropriate cautions in order to obtain optimum performance and safety.

- Charging** : Charging current, voltage, time and temperature should be within the limit specified in the specification.
Reverse charging should be strictly prohibited.
Improper charging may generate heat, smoke, rupture or flame, and may cause leakage or damage to the cell and personal injury.
- Discharging** : Discharging current, voltage and temperature should be within the limit specified in the specification.
Short circuit and over discharging should be strictly prohibited.
Over discharge may occur by self-discharge if the cell is left idle for a long time, or by leakage current of equipment.
Improper discharging may generate heat, smoke, rupture or flame, and may cause leakage or damage to the cell and personal injury.
- Storage** : Storage voltage, time, temperature and relative humidity should be within the limit specified in the specification. Storage is recommended in low temperature, low humidity, no corrosive gas atmosphere.
Long term storage may cause permanent loss of capacity.
- Cycle Life** : Cycle life performance differs by conditions of charging, discharging, temperature and/or storage condition.
- Shipping** : The cell should be checked after long term storage prior to shipment.
Packaging should be according to latest requirement of IATA and IMDG.
- Product Design** : Do not solder directly on bare cell.
Cell should be positioned far from heat source and heat components.
Shock absorber should be equipped to minimize shock on the cell.
Protection circuit should be equipped to insure safety in case of misuse and abnormal conditions.
Battery should be designed to connect only to specified charger and system.
Product design should be able to avoid short circuit, reverse connection, vibration, shock and crush of battery.
Improper product design may cause damage and personal injury.
- Product Assembly** : Battery cell should be inspected visually before product assembly to avoid usage of damaged cell (for example, sleeve damage, battery distortion, or leaking).
Excessive force on the battery terminals and battery surface should be avoided. Precaution should be taken to avoid short circuit of cell.
Precaution should be taken when cell is moved / transported to other place.
Battery pack should be assembled by cells from same batch, with similar capacity, voltage, internal resistance and charge level.
- Warning** : The cell may present risk of fire and chemical burn if mistreated.
Do not disassembly cell, immersion in water and dispose in fire.
Do not use cell with unusual conditions such as odors or leakage or heat.
Cell should be disposed in discharged state.
Improper handling may cause damage and personal injury.
Keep the cell away from children.

Information is for reference only and is not construed as warranties either expressed or implied, of future performance. Performance varies with time, discharge and storage condition.. 1 year limited guarantee against manufacturing defects. Other problem caused by misuse, mishandling of cell, or malfunction of equipment, is not under the warranty.