

KBJ

Features

- ◇ Rating to 1000V PRV
- ◇ Surge overload rating to 200 Amperes peak
- ◇ Ideal for printed circuit board
- ◇ Reliable low cost construction utilizing molded plastic technique results in inexpensive product
- ◇ Lead solderable per MIL-STD-202 method 208

Mechanical Data

- ◇ Polarity: Symbols molded on body
- ◇ Weight: 0.23 ounces, 6.6 grams
- ◇ Mounting position: Any

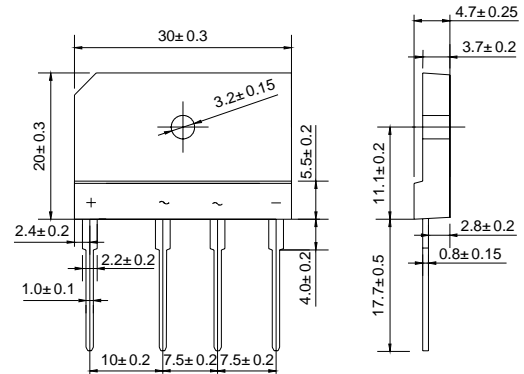

Dimensions in millimeters

MAXIMUM RATINGS AND ELECTRICAL CHARACTERISTICS

Ratings at 25°C ambient temperature unless otherwise specified.

Single phase, half wave, 60 Hz, resistive or inductive load. For capacitive load, derate by 20%.

		GSIB 25005	GSIB 2501	GSIB 2502	GSIB 2504	GSIB 2506	GSIB 2508	GSIB 2510	UNITS
Maximum recurrent peak reverse voltage	V_{RRM}	50	100	200	400	600	800	1000	V
Maximum RMS voltage	V_{RMS}	35	70	140	280	420	560	700	V
Maximum DC blocking voltage	V_{DC}	50	100	200	400	600	800	1000	V
Maximum average forward Output current @ $T_A=25^\circ C$	$I_{F(AV)}$	25.0							A
Peak forward surge current 8.3ms single half-sine-wave superimposed on rated load	I_{FSM}	200.0							A
Maximum instantaneous forward voltage at 12.5 A	V_F	1.0							V
Maximum reverse current @ $T_A=25^\circ C$ at rated DC blocking voltage @ $T_A=100^\circ C$	I_R	10.0 1.0							μA mA
Typical junction capacitance per element	C_J	85							pF
Typical thermal resistance	$R_{\theta JC}$	0.6							$^\circ C/W$
Operating junction temperature range	T_J	- 55 ---- + 150							$^\circ C$
Storage temperature range	T_{STG}	- 55 ---- + 150							$^\circ C$

NOTES: 1. Measured at 1.0MHz and applied reverse voltage of 4.0V DC

2. Device mounted on 300mm X 300mm X 1.6mm cu Plate heatsink.

Ratings AND Characteristic Curves

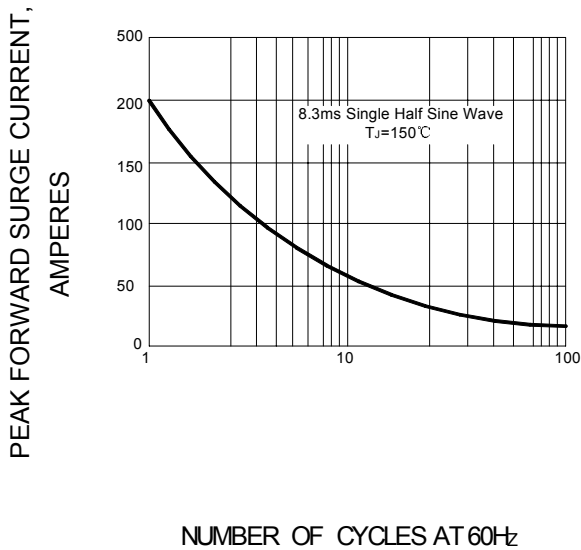
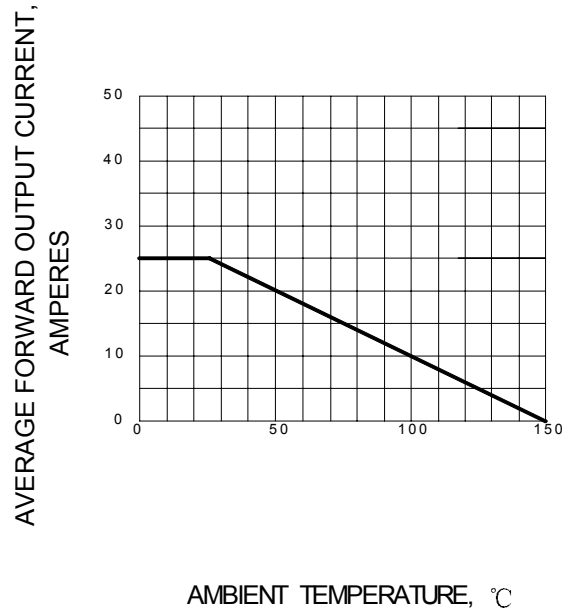
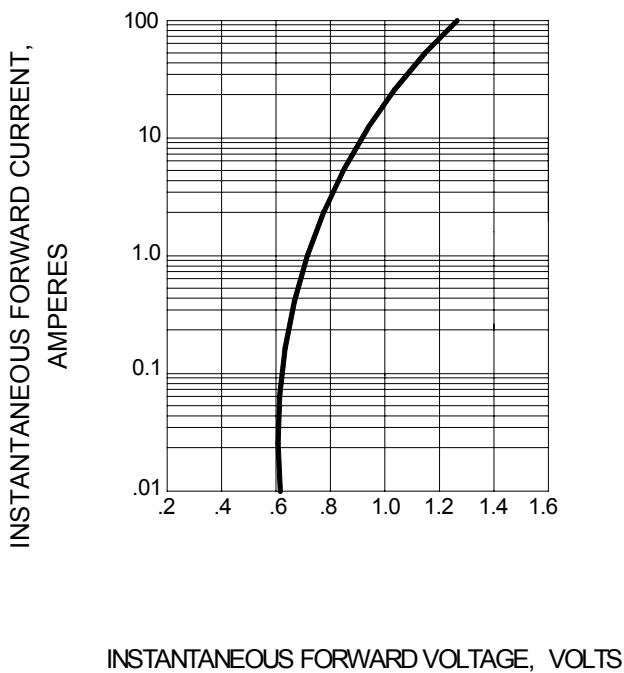
FIG.1 – PEAK FORWARD SURGE CURRENT

FIG.2 – FORWARD DERATING CURVE

FIG.3 – TYPICAL FORWARD CHARACTERISTIC

FIG.4 – TYPICAL JUNCTION CAPACITANCE
