

SKY TECHNOLOGY (SHENZHEN)CO.,LIMITED	Doc.No.:	
	REV : A	PAGE : 1/19
SPEC TITLE DOCUMENT CONTROL SPECIFICATION	EFFECTIVE DATE : 2013-11-25	

Specifications

TFT-LCDmodule

Model No 'FRD2403702

For Customer's Acceptance	
Approved by	Comment

	Signature	Date
Prepared by		
Checked by		
Approved by		

SKY TECHNOLOGY (SHENZHEN)CO.,LIMITED

WWW.SKY-LCD.COM

SALES@SKYLCD.COM

SKY TECHNOLOGY (SHENZHEN)CO.,LIMITED	Doc.No.:	
	REV : A	PAGE : 2/19
SPEC TITLE DOCUMENT CONTROL SPECIFICATION	EFFECTIVE DATE : 2013-11-25	

Contents

1	General Description	3
1.1	Features	3
1.2	Application	3
2	Outline Dimension	4
3	Electrical Characteristics	5
3.1	TFT-LCD Module	5
3.2	Back-Light Unit.....	5
4	Block Diagram	6
5	TFT-LCM Interface Specification	7
6	Description of Interface' Signal.....	8
6.1	Register Selection	8
6.2	Values of /CS during GRAM Write.....	8
6.3	80-system Interface Timing.....	8
6.4	DC Characteristics.....	9
6.5	AC Characteristics	10
6.6	Reset Timing Characteristics.....	11
7	Optical Specification.....	12
8	Environment Absolute Maximum Ratings	15
9	Reliability Test Items	10
10	Package	16
11	Precautions	17
11.1	Handling	17
11.2	Storage.....	18
11.3	Operation	18
11.4	Touch Panel Mounting Notes	18
11.5	Others	19
12	Records of Version.....	19

SKY TECHNOLOGY (SHENZHEN)CO.,LIMITED	Doc.No.:	
	REV : A	PAGE : 3/19
SPEC TITLE DOCUMENT CONTROL SPECIFICATION	EFFECTIVE DATE : 2013-11-25	

1 General Description

FRD2403702 is a transmissive type a-Si TFT-LCD (amorphous silicon thin film transistor liquid crystal display) module, which is composed of a TFT-LCD panel, a driver circuit a backlight unit, The panel size is 2.4 inch and thresolution is 240x320. High image quality a-Si TFT LCD module. Partial-screen display function is available. Sleep and Stand-by modes are available for power saving.

1.1 Features

No	Item	Specification	Remark
1	Display Mode	Normally White	
2	Screen Size	2.4inch (diagonal)	
3	Resolution	240XRGBX320	
4	Color Number	262K	
5	Color Arrangement	RGB-stripe	
6	Driver IC	ILI9341	
7	Back Light	White LED*4	
8	Viewing Direction	12 o'clock	
9	Interface	8&16-bit interface.	
10	Surface Treatment	UV Cut	
11	touch panel	N/A	

1.2 Application

- ◆ Mobile phone.
- ◆ Portable multimedia device.

2 Outline Dimension

The mechanical detail is shown in Fig. 1 and summarized in Table 1 below.

Parameter	Specifications	Unit
Outline dimensions	42.72(W) x60.26(H) x 2.25(D) (LCM,no include FPC)	mm
Active area	36.72(W) x48.96(H)	mm
Resolution	240(H)RGBx 320(V) dots	-
Dot size	0.153(H) x 0.153(V)	mm
Overall Weight		grams

SKY TECHNOLOGY (SHENZHEN)CO.,LIMITED	Doc.No.:	
	REV : A	PAGE : 5/19
SPEC TITLE DOCUMENT CONTROL SPECIFICATION	EFFECTIVE DATE : 2013-11-25	

Figure 1: Module specification of the module

3 Electrical Characteristics

3.1 TFT-LCD Module

Ta=25

Item	Symbo	Value			Unit	Notes
		Min	Typ	Max		
Supply Voltage for logic	Vcc	2.5	2.8	3.3	V	
	Vci	2.5	2.8	3.3		
TFT Gate ON Voltage	VGH *	10	15	20	V	
TFT Gate OFF Voltage	VGL	-15	-8	-5	V	
Operating temperature	Top	-20		+70		
Storage temperature	Tst	-30		+80		

3.2 Back-Light Unit

Item	Symbol	Min.	Typ.	Max.	Unit	Remark
Current	IF	--	15X4	20X4	mA	IF=60mA VF=3.2V
Forward voltage	VF	3.0	3.2	3.4	V	
Chroma	X	0.250		0.30		
	Y	0.250		0.30		
Brightness	L	2800			Cd/m2	
Uniformity	UBL	80			%	

- 4 LEDs used
- The luminous intensity of LED is strongly dependent on the driving current.
- It is recommended the input of backlight to be constant current rather than constant voltage.

SKY TECHNOLOGY (SHENZHEN)CO.,LIMITED	Doc.No.:	
	REV : A	PAGE : 6/19
SPEC TITLE DOCUMENT CONTROL SPECIFICATION	EFFECTIVE DATE : 2013-11-25	

4 Block Diagram

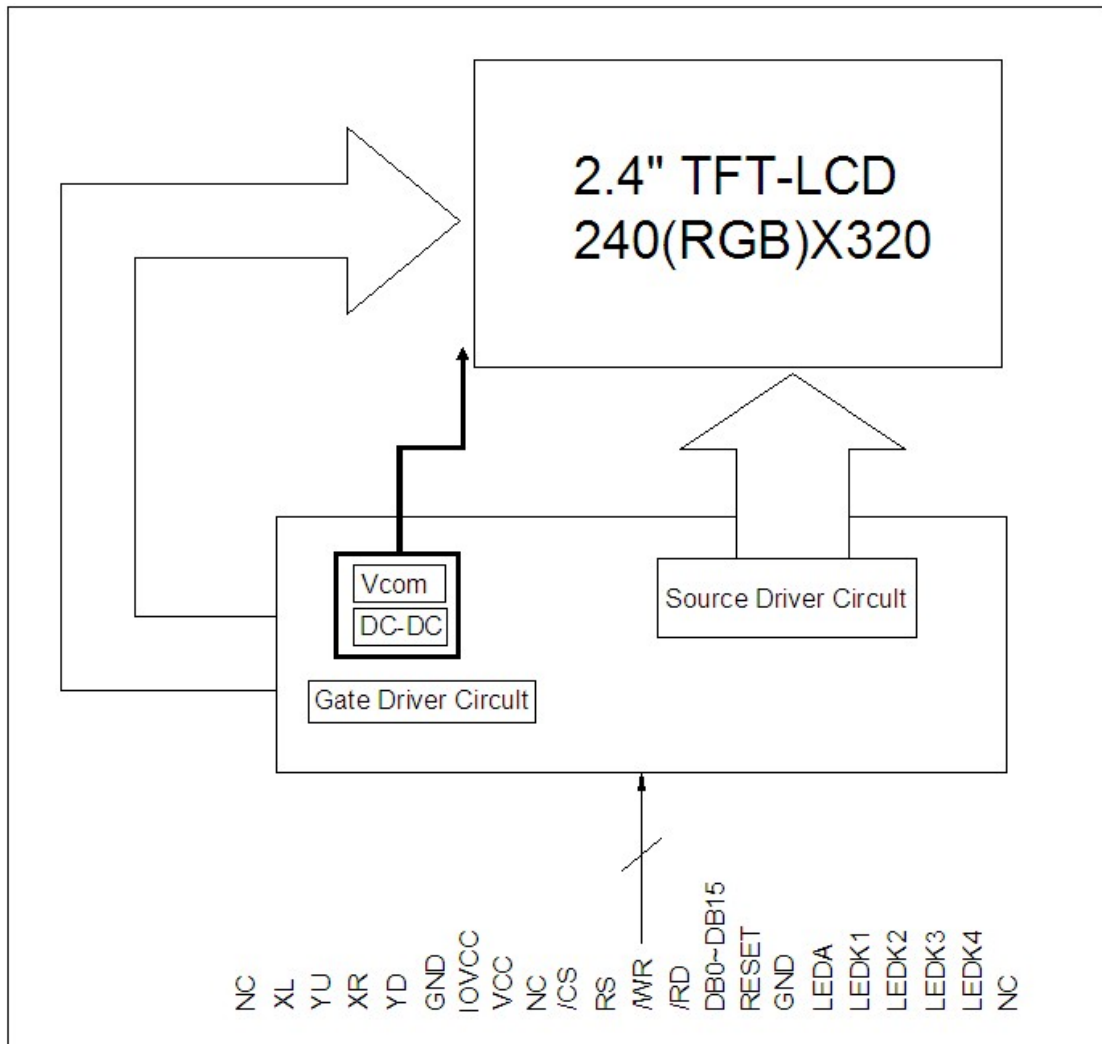

SKY TECHNOLOGY (SHENZHEN)CO.,LIMITED	Doc.No.:	
	REV : A	PAGE : 7/19
SPEC TITLE DOCUMENT CONTROL SPECIFICATION	EFFECTIVE DATE : 2013-11-25	

5 TFT-LCM Interface Specification

Pin No	Symbol	Description	Note
1~4	DB0~DB3	NC	
5	GND	Ground	
6	VCC	Power supply input for LCM: 2.8V	
7	/CS	Chip select input pin.	
8	RS	Data/Instruction select input pin ---RS='H ': Display data. ---RS='L ': Instruction data.	
9	WR	A write strobe signal can be input via this pin and initiallizes a write operation when the signal is low.	
10	RD	A read strobe signal can be input via this pin and initiallizes a read operation when the signal is low.	
11	IM0	Select a mode for interface to an MCU When IM0=0,IM3=0,setting 16bit when IM0=1,IM3=0,setting 8080 8bit	
12	XL	NC	
13	YU	NC	
14	XR	NC	
15	YD	NC	
16	LED-A	Power supply Cathode input for backlight	
17	LED-K1	Power supply Cathode input for backlight1	
18	LED-K2	Power supply Cathode input for backlight2	
19	LED-K3	Power supply Cathode input for backlight3	
20	LED-K4	Power supply Cathode input for backlight4	
21	NC	NC	
22	DB4	NC	
23~30	DB10~17	DATA bus	
31	/RESET	Reset signal input Pin	
32	VCI	Power supply input for LCM: 2.8V	
33	IOVCC	Power supply input for LCM: 1.8V	
34	GND	Ground	
35~37	DB5~DB7	NC	

	Doc.No.:	
	REV : A	PAGE : 8/19
SPEC TITLE DOCUMENT CONTROL SPECIFICATION	EFFECTIVE DATE : 2013-11-25	

6 Description of Interface'Signal

6.1 Register Selection

<i>/WR</i>	<i>/RD</i>	<i>RS</i>	<i>Operations</i>
0	1	0	Write command to register
1	0	0	Read command data to RAM
0	1	1	Write display data to RAM
1	0	1	Read display data from RAM

6.2 Values of /CS during GRAM Write

<i>/CS</i>	<i>Operations</i>
0	Data is written to the GRAM. RAM address is updated.
1	Data is not written to the GRAM. RAM address is not updated.

6.3 80-system Interface signals

180 18-/16-bit System Bus Interface Timing

(a) Write to register



(b) Read from register

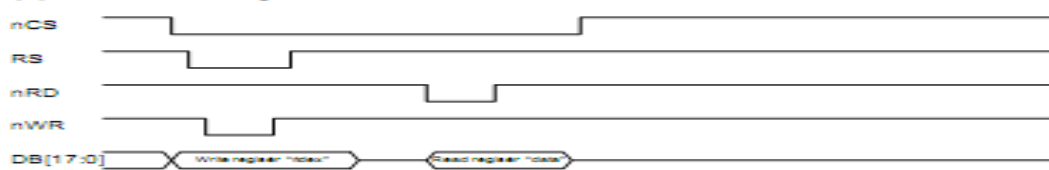

180 9-/8-bit System Bus Interface Timing

(a) Write to register



(b) Read from register



SKY TECHNOLOGY (SHENZHEN)CO.,LIMITED	Doc.No.:	
	REV : A	PAGE : 9/19
SPEC TITLE DOCUMENT CONTROL SPECIFICATION	EFFECTIVE DATE : 2013-11-25	

6.4 DC Characteristics (Vcc=2.4~ 3.3V, IOVcc=1.65-3.3V,Ta=-40 ~ 85°C)

(VCC = VCI=2.40 ~ 3.0V, IOVCC = 1.65 ~ 3.30V, Ta= -40 ~ 85 °C)

Item	Symbol	Unit	Test Condition	Min.	Typ.	Max.	Note
Input high voltage	V _{IH}	V	IOVCC= 1.8 ~ 3.3V	0.8*IOVCC	-	IOVCC	-
Input low voltage	V _{IL}	V	IOVCC= 1.8 ~ 3.3V	-0.3	-	0.2*IOVCC	-
Output high voltage(1) (DB0-17 Pins)	V _{OH1}	V	IOH = -0.1 mA	0.8*IOVCC	-	-	-
Output low voltage (DB0-17 Pins)	V _{OL1}	V	IOVCC=1.65-3.3V	-	-	0.2*IOVCC	-
I/O leakage current	I _{IL}	μA	Vin = 0 ~ VCC	-0.1	-	0.1	-
Current consumption during normal operation (V _{CC} : - GND)	I _{CP}	μA	VCC=2.8V , T _a =25°C , fOSC = 512KHz (Line) GRAM data = 0000h	-	100 (VCC)	-	-
Current consumption during standby mode (V _{CC} : - GND)	I _{ST}	μA	VCI=2.8V , T _a =25 °C	-	30	50	-
LCD Drive Power Supply Current (DDVDH-GND)	I _{LCD}	mA	VCI=2.8V , VREG1OUT=4.8V DDVDH=5.2V , Frame Rate: 70Hz, line-inversion, Ta=25°C, GRAM data = 0000h,	-	5.0	-	-
LCD Driving Voltage (DDVDH-GND)	DDVDH	V	-	4.5	-	6	-
Dispersion of the Average Output Voltage	V	mV	-	-10	-	10	-

6.5 AC Characteristics

Normal Write Mode (IOVCC = 1.65~3.3V)

Item	Symbol	Unit	Min.	Typ.	Max.	Test Condition
Bus cycle time	Write	t _{CYCW}	ns	100	-	-
	Read	t _{CYCR}	ns	300	-	-
Write low-level pulse width	PW _{LW}	ns	50	-	500	-
Write high-level pulse width	PW _{HW}	ns	50	-	-	-
Read low-level pulse width	PW _{LR}	ns	150	-	-	-
Read high-level pulse width	PW _{HR}	ns	150	-	-	-

Write / Read rise / fall time	t _{WRr} /t _{WRf}	ns	-	-	25	
Setup time	Write (RS to nCS, E/nWR)	t _{AS}	ns	10	-	-
	Read (RS to nCS, RW/nRD)	t _{AS}	ns	5	-	-
Address hold time	t _{AH}	ns	5	-	-	
Write data set up time	t _{DCW}	ns	10	-	-	
Write data hold time	t _H	ns	15	-	-	
Read data delay time	t _{DDR}	ns	-	-	100	
Read data hold time	t _{DHR}	ns	5	-	-	

SPEC TITLE

DOCUMENT CONTROL SPECIFICATION

EFFECTIVE DATE : 2013-11-25

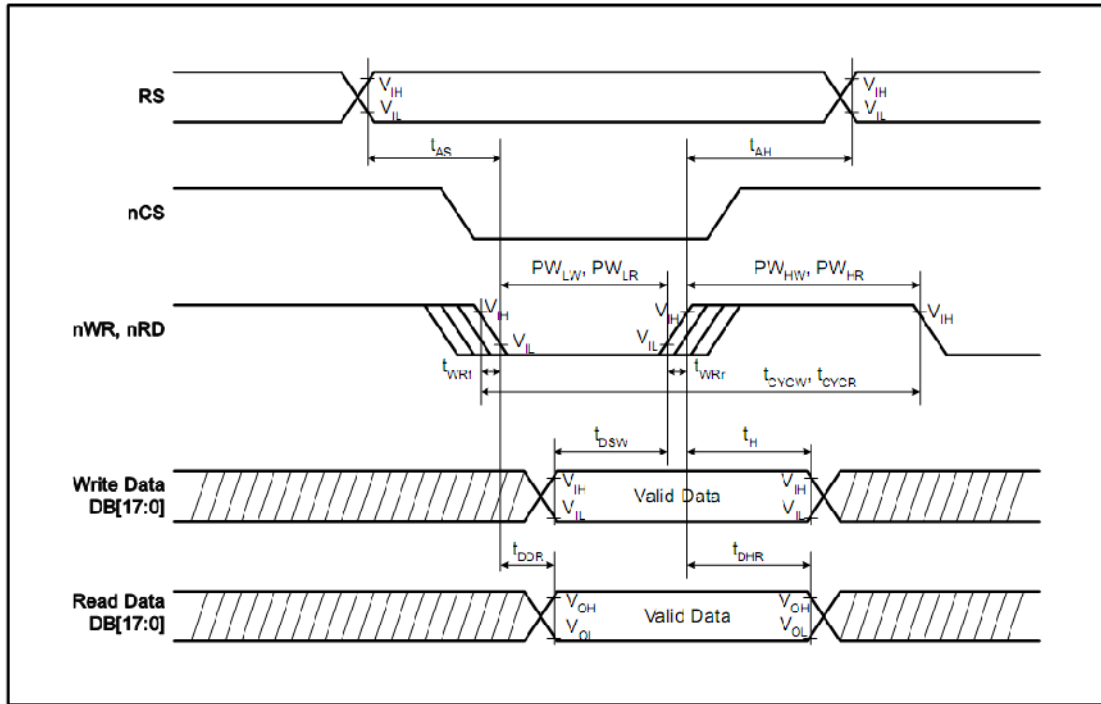

6.6 Reset Timing Characteristics

Reset Timing Characteristics (IOVCC = 1.65 ~ 3.3 V)

Item	Symbol	Unit	Min.	Typ.	Max.
Reset low-level width	t_{RES}	ms	1	-	-
Reset rise time	t_{RES}	μs	-	-	10

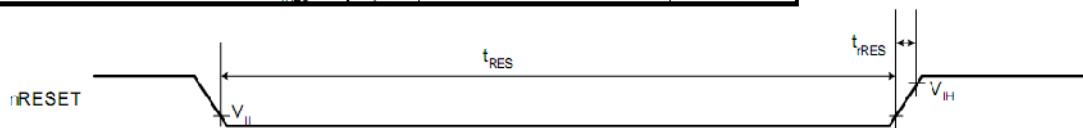

SKY TECHNOLOGY (SHENZHEN)CO.,LIMITED	Doc.No.:	
	REV : A	PAGE : 11/19
SPEC TITLE DOCUMENT CONTROL SPECIFICATION	EFFECTIVE DATE : 2013-11-25	

7 Optical Specification

Ta=25 , Vcc=Vci=2.8V, IB=80mA

Item		Symbol	Condition	Min.	Typ.	Max.	Unit	Remark
Brightness		B	=0°	120	170	--	cd/m ²	Note 1 With out TP
Contrast Ratio		CR		150	200	--	--	Note 2
Response Time		Rising : T _r	Normal viewing angle	--	25	40	ms	Note 3
		Falling : T _f						
Color Chromaticity (CIE 1931)	White	X	At the center of panel	0.273	0.320	0.330	--	
		Y		0.304	0.343	0.363		
	Red	X	Backlight On	0.584	0.604	0.624		
		Y		0.305	0.325	0.345		
	Green	X	Equipment: BM7 Field=2°	0.279	0.299	0.329		
		Y		0.587	0.600	0.612		
	Blue	X	0.115	0.135	0.155			
		Y	0.060	0.063	0.075			
Viewing Angle	Top	U	CR 10 Backlight On Equipment: BM7 Field=2°	45	--	--	Degrees	Note 4
	Bottom	D		15	--	--		
	Left	L		40	--	--		
	Right	R		40	--	--		
Uniformity		Un	=0° Normal viewing angle Backlight On Equipment: BM7 Field=2°	70	80	--	%	Note 5

SKY TECHNOLOGY (SHENZHEN)CO.,LIMITED	Doc.No.:	
	REV : A	PAGE : 12/19
SPEC TITLE DOCUMENT CONTROL SPECIFICATION	EFFECTIVE DATE : 2013-11-25	

Note 1: The brightness test equipment setup

$I_B=60mA$, Field= 2° (As measuring "black" image, field= 2° is the best testing condition.)

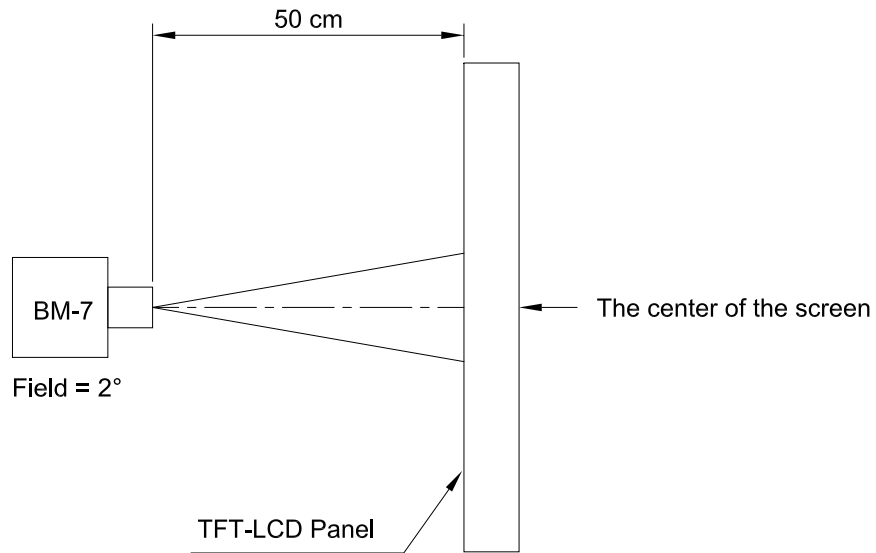

Note 2: Definition of contrast ratio (C.R)

$$C.R = \frac{\text{Brightness When LCD is at "White" State}}{\text{Brightness When LCD is at "Black" State}}$$

Note 3: Definition of response time

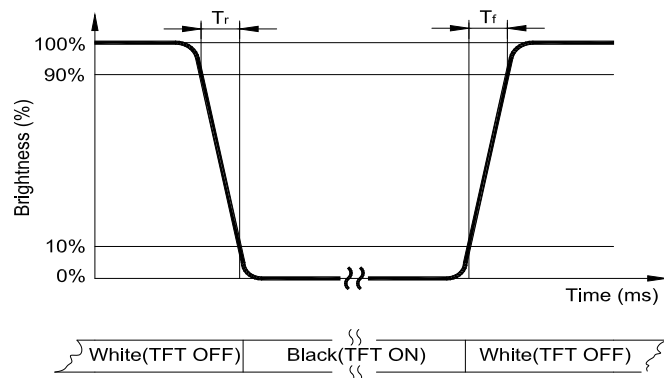

	Doc.No.:	
	REV : A	PAGE : 13/19
SPEC TITLE DOCUMENT CONTROL SPECIFICATION	EFFECTIVE DATE : 2013-11-25	

Note 4: Definition of viewing angle

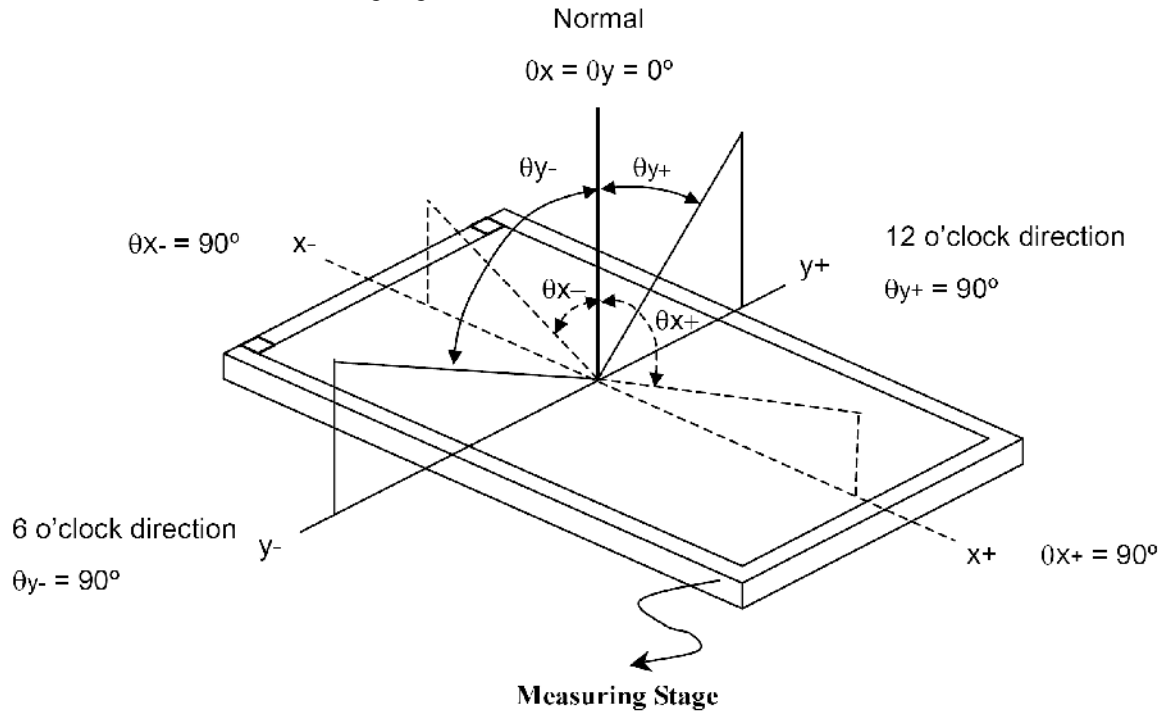

Note 5: Definition of uniformity (U_n)

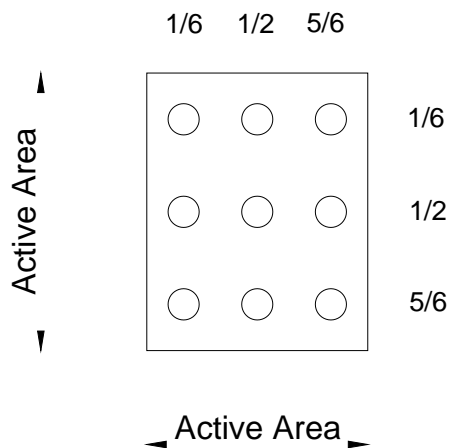

$$U_n = \frac{B_{min}}{B_{max}} \times 100\%$$

	Doc.No.:	
	REV : A	PAGE : 14/19
SPEC TITLE DOCUMENT CONTROL SPECIFICATION	EFFECTIVE DATE : 2013-11-25	

8 Environment Absolute Maximum Ratings

Item	Symbol	Min	Max	Unit	Remark
Operation temperature range	Top	-20	70		Ambient
Storage temperature range	Tst	-30	80		Ambient

- Corrosive gas environment is not acceptable.
- TFT-LCD color will change slightly depending on environment temperature. This phenomenon is reversible. Current reduction rate of LED backlight is according to the graph indicated below:

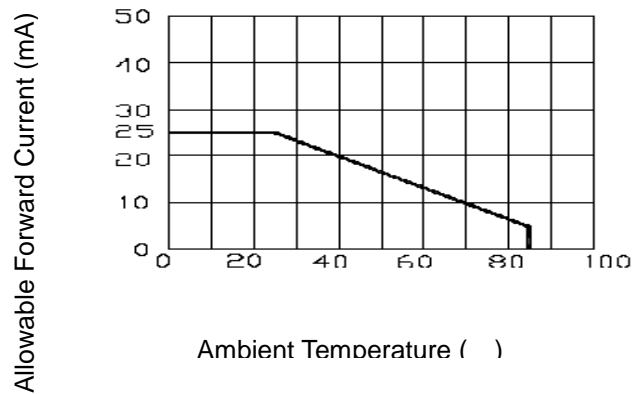

9 Reliability Test Items

Item	Test Condition		Criterion
High Temperature Storage	80 , 240 hrs		There should be no change which might affect the practical display function when the display quality test is conducted under normal operating condition.
Low Temperature Storage	-30 , 240 hrs		
High Temp. & High Humidity Storage	60 , 90% RH, 240 hrs		
Vibration Test (Non-operating)	Freq.:10~55~10 Hz, Amp.:1.5mm 1 hr for each direction of X, Y, Z		
Electrostatic Discharge Test (Non-operating)	Terminals	150 pF, 0 , ±300 V, Contact	
	Panel	150 pF, 330 , ±8 KV, Air	
Thermal Shock (Static)	-30 , 30 min /80 , 30 min, 20 cycles		
High Temperature Operation	70 , 240 hrs		
Low temperature Operation	-20 , 240 hrs		
High Temperature & High Humidity (Operating)	50 , 90% RH, 240 hrs		
FPC Peeling Strength Test	Pull speed: 50 mm/min, +90°,		> 400gf/cm

	Doc.No.:	
	REV : A	PAGE : 15/19
SPEC TITLE DOCUMENT CONTROL SPECIFICATION	EFFECTIVE DATE : 2013-11-25	

10 Package

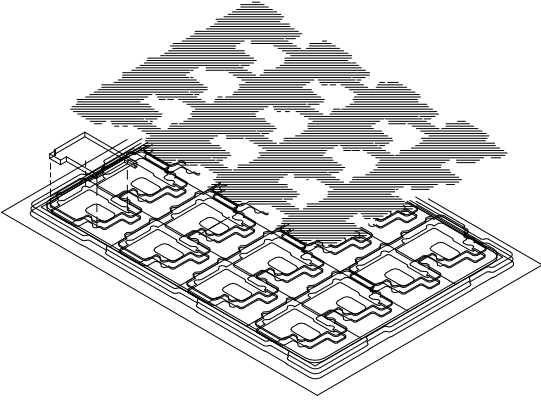
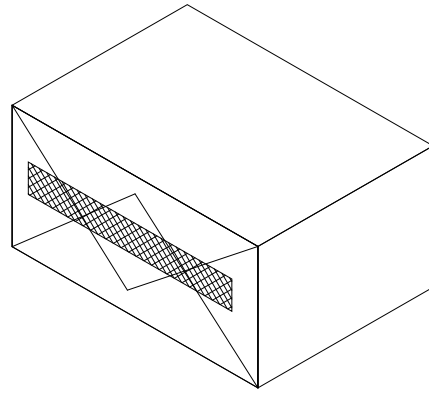
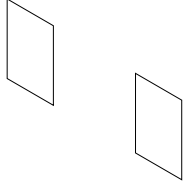
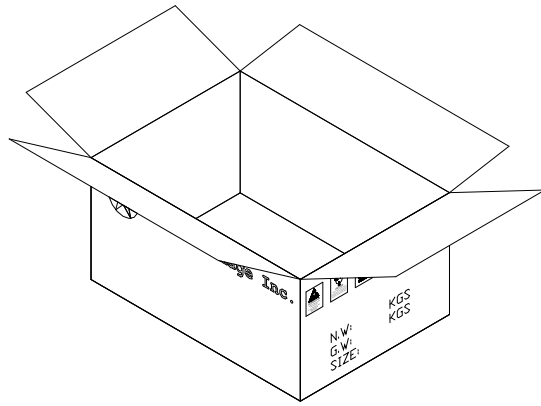
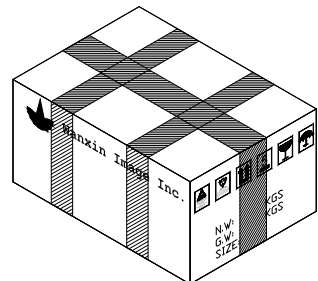
<p>1</p>  <p>16 pcs per tray + 1 cover (EPE)</p>	<p>4</p>  <p>Packing bag</p>
<p>2</p>  <p>25 trays + 1 dummy tray = 400 ps</p>	<p>5</p>  <p>Putting bag into carton Protected by 6 pieces of cushion EPE sheet</p>
<p>3</p> <p>Putting trays into anti-electrostatic bag</p>	<p>6</p>  <p>Packing carton with sealing tape Carton outline size: 417×310×262 (mm)</p>

SKY TECHNOLOGY (SHENZHEN)CO.,LIMITED	Doc.No.:	
	REV : A	PAGE : 16/19
SPEC TITLE DOCUMENT CONTROL SPECIFICATION	EFFECTIVE DATE : 2013-11-25	

11 Precautions

Please pay attentions to the followings as using the LCD module.

11.1 Handling

- (a) Do not apply strong mechanical stress like drop, shock or any force to LCD module. It may cause improper operation, even damage.
- (b) Because the polarizer is very fragile and easy to be damaged, do not hit, press or rub the display surface with hard materials.
- (c) Do not put heavy or hard material on the display surface, and do not stack LCD modules.
- (d) If the display surface is dirty, please wipe the surface softly with cotton swab or clean cloth.
- (e) Avoid using Ketone type materials (e.g. Acetone), Toluene, Ethyl acid or Methyl chloride to clean the display surface. It might damage the touch panel surface permanently. The recommended solvents are water and Isopropyl alcohol.
- (f) Wipe off water droplets or oil immediately.
- (g) Protect the LCD module from ESD. It will damage the LSI and the electronic circuit.
- (h) Do not touch the output pins directly with bare hands.
- (i) Do not disassemble the LCD module.
- (j) Do not lift the FPC of Touch Panel.

11.2 Storage

- (a) Do not leave the LCD modules in high temperature, especially in high humidity for a long time.
- (b) Do not expose the LCD modules to sunlight directly.
- (c) The liquid crystal is deteriorated by ultraviolet. Do not leave it in strong ultraviolet ray for a long time.
- (d) Avoid condensation of water. It may cause improper operation.

SKY TECHNOLOGY (SHENZHEN)CO.,LIMITED	Doc.No.:	
	REV : A	PAGE : 17/19
SPEC TITLE DOCUMENT CONTROL SPECIFICATION	EFFECTIVE DATE : 2013-11-25	

- (e) Please stack only up to the number stated on carton box for storage and transportation. Excessive weight will cause deformation and damage of carton box.

11.3 Operation

- (a) When mounting or dismounting the LCD modules, turn the power off.
- (b) Protect the LCD modules from electric shock.
- (c) The Driver IC control algorithms stated above should always obeyed to avoid damaging the LSI and electronic circuit.
- (d) Be careful to avoid mixing up the polarity of power supply for backlight.
- (e) Absolute maximum rating specified above has to be always kept in any case. Exceeding it may cause non-recoverable damage of electronic components or, nevertheless, burning.
- (f) When a static image is displayed for a long time, remnant image is likely to occur.
- (g) Be sure to avoid bending the FPC to an acute shape, it might break FPC.
- (h) Most of the touch screens have air vent to equalize the inside air pressure to the outside one. The air vent must be open and liquid contact must be avoided as the liquid may be absorbed if the liquid is accumulated near the air vent.
- (i) For the fragility of ITO film, it should avoid to use too tapering pen as the input material.

11.4 Touch Panel Mounting Notes

- (a) If a cushion is used between bezel/housing and film must be choose as free as enough to absorb the expansion and contraction to avoid the distortion of film.
- (b) The cushion must be placed out of the Viewing Area.
- (c) Bezel/Housing edge must be posited between Key Area and Viewing Area. The edge enters the Key Area may cause unexpected input if the gap is too narrow or foreign particles like dusts exist between Bezel/Housing and ITO film.
- (d) Mounting example:

SKY TECHNOLOGY (SHENZHEN)CO.,LIMITED	Doc.No.:	
	REV : A	PAGE : 18/19
SPEC TITLE DOCUMENT CONTROL SPECIFICATION	EFFECTIVE DATE : 2013-11-25	

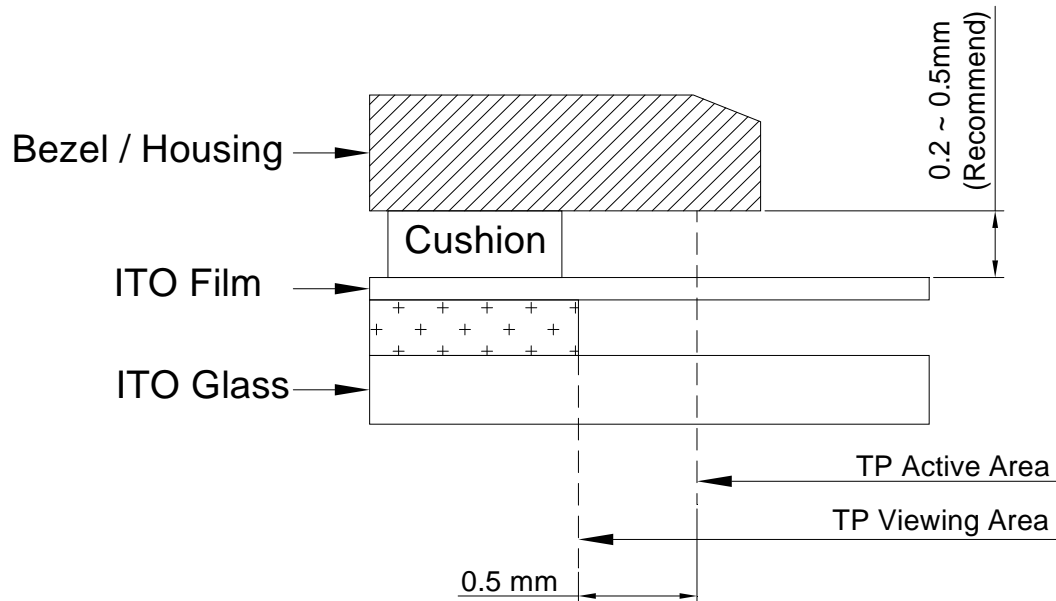

The corner part has conductivity. Do not touch any metal part after mounting.

11.5 Others

- a) If the liquid crystal leaks from the panel, it should be kept away from the eyes or mouth.
- b) For the fragility of polarizer, it is recommended to attach a transparent protective plate over the display surface.
- c) It is recommended to peel off the protection film on the polarizer slowly so that the electrostatic charge can be minimized.

