

Sample Approval Sheet

(Product type):LED		
(Product name): 5MM red& yellow-green led common cathode		
(Part No.):		
(Sample No.):		(version):A1
(Acknowledgement Numbers):		
Signatures		
(Approved)	(Checked)	(Drawn)

Customer		
(Corporation):		
(Material No.):		
(Part No.):		
Customer Signatures		

Feature

- *Low power consumption
- *Long life-solid state reliability
- *Available on tape and reel
- *RoHS compliant

Package outline dimensions

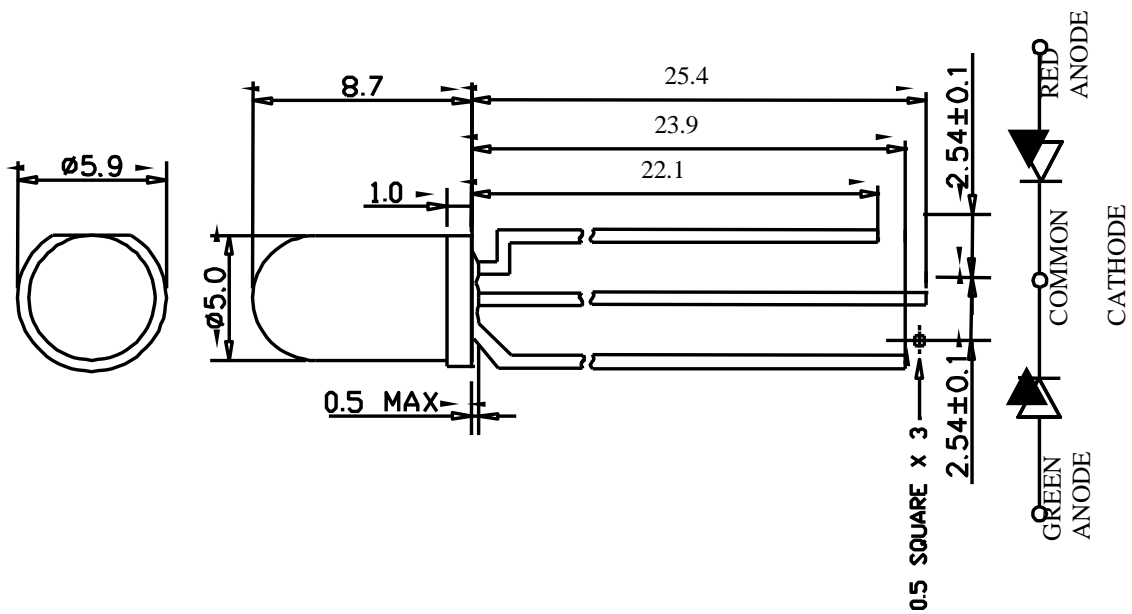

Note:

- 1.All dimensions are in millimeters;
- 2.Tolerance is ± 0.25 unless otherwise noted;
- 3.Lead spacing is measured where the leads emerge from the package;
- 4.Specifications are subject to change without notice.

Electrical characteristics data sheet

Selection Guide

Part No.	Emitted Color	Resin color	Viewing Angle 20 _{1/2}
	Red& yellow-green	White diffused	55°

Absolute Maximum Ratings at Ta=25°C

Parameter	Symbol	Value		Unit
		R	H	
Power dissipation	Pd	72	72	mW
DC Forward Current	If	30	30	mA
Peak Forward Current ⁽¹⁾	Ifp	100	100	mA
Reverse Voltage	Vr	5	5	V
Electro-Static-Discharge (HBM)	ESD	2000	2000	V
Operating Temperature	Topr	-25to+85		°C
Storage Temperature	Tstg	-40to+100		°C
Lead Solder Temperature ⁽²⁾	Tsol	260 for 5sec		°C

Notes:

1.1/10 duty cycle,0.1ms pulse width

2.2mm below package base.

Electrical/Optical Characteristics Ta=25°C

Parameter	Symbol	Condition	Emitting Color	Value			Unit
				Min.	Typ.	Max.	
Forward voltage	Vf	If=20mA	R	---	2.0	2.4	V
			H	---	2.2	2.6	
Luminous intensity	Iv	If=20mA	R	270	350	---	mcd
			H	120	270	---	
Dominant wavelength	λd	If=20mA	R	620	622	630	nm
			H	565	574	578	
Peak wavelength	λp	If=20mA	R	---	635	---	nm
			H	---	568	---	
Reverse current	Ir	Vr=5V		---	---	10	μA

Notes:

1. Forward Voltage: ±0.1V

2. Wavelength: ±1.5nm

3. Luminous Intensity: ±10%

Typical Electro-Optical Characteristics Curves

FORWARD CURRENT VS. APPLIED VOLTAGE

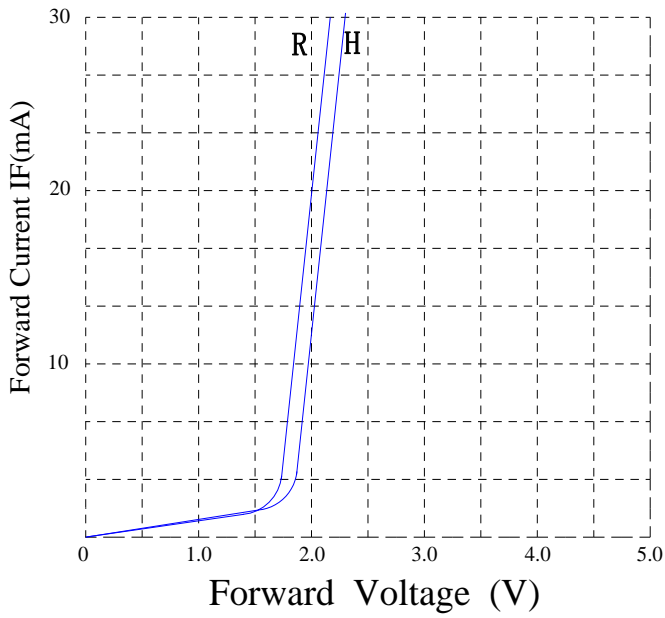

FORWARD CURRENT VS. LUMINOUS INTENSITY

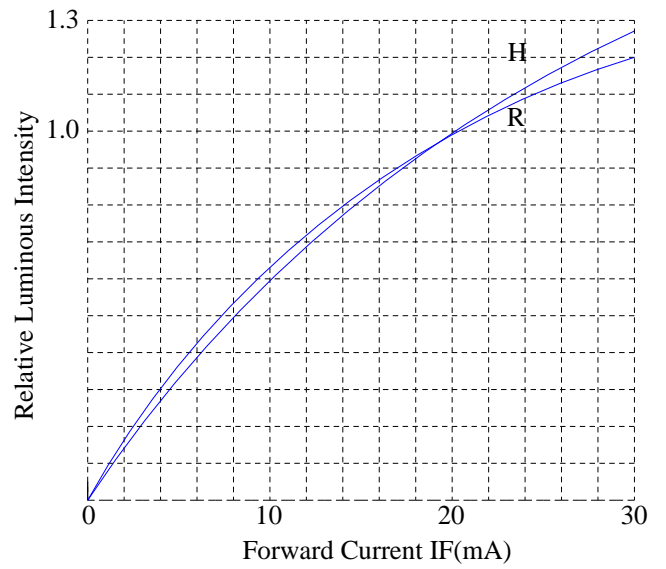

AMBIENT TEMPERATURE VS. FORWARD CURRENT

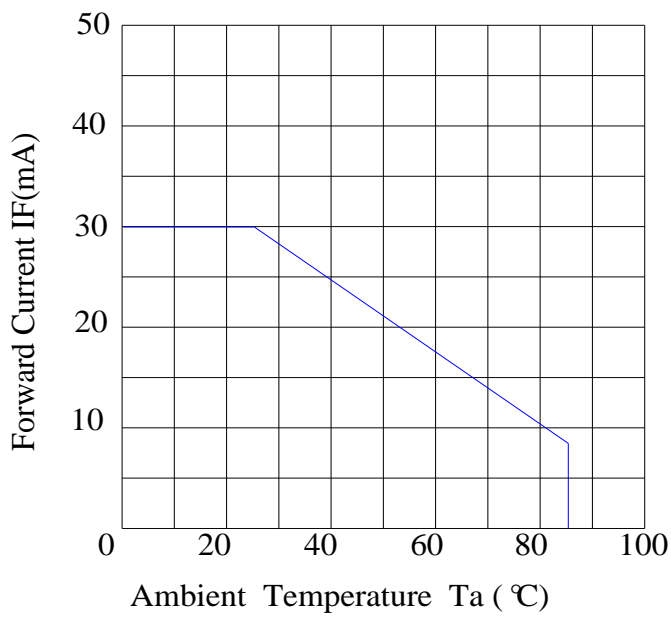

RADIATION DIAGRAM

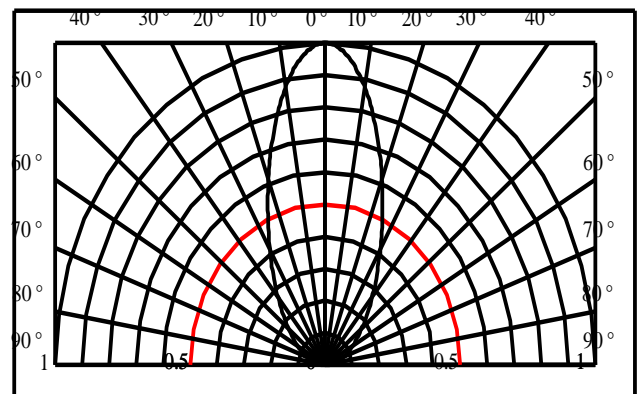

Reliability Test Items and Conditions

1、 Test items and result

Test Item	Ref. Standard	Test Condition	Note	Number of Damaged
Resistance to Soldering Heat	JEITA ED-4701 300 301	Tsld=260℃, 10sec	2 times	0/50
Solderability	JEITA ED-4701 300 303	Tsld=215±5℃, 3sec	1time over 95%	0/50
Thermal Shock	JEITA ED-4701 300 307	-40℃ 15min ↑↓ 100℃ 15min	100cycles	0/50
Temperature Cycle	JEITA ED-4701 100 105	-40℃ 30min ↓↑ 5min 100℃ 30min	100cycles	0/50
Moisture Resistance Cycle	JEITA ED-4701 200 203	65℃~25℃~ -10℃ 90%RH 24hrs./1cycle	100cycles	0/50
High Temperature Storage	JEITA ED-4701 200 201	Ta=100℃	1000 hrs	0/50
High Temperature High Humidity Storage	JEITA ED-4701 100 103	Ta=60℃, 90%RH	1000 hrs	0/50
Low Temperature Storage	JEITA ED-4701 200 202	Ta= -40℃	1000 hrs	0/50
Steady State Operating Life		Ta=25℃, IF=20mA	1000 hrs	0/50
Steady State Operating Life of High Temperature		Ta=85℃, IF=20mA	1000 hrs	0/50
Steady State Operating Life of High Humidity Heat		60℃, 90%RH, IF=20mA	1000 hrs	0/50
Steady State Operating Life of Low Temperature		Ta= -30℃, IF=20mA	1000 hrs	0/50
Drop		H=75cm	3 cycles	0/50

2、 Criteria for judging damage

Item	Symbol	Test Conditions	Criteria for Judgment	
			Min	Max
Forward voltage	VF	IF=20mA	--	U. S. L*) × 1. 1
Reverse current	IR	VR=5V	--	U. S. L*) × 2. 0
Luminous intensity	IV	IF=20mA	L. S. L**) × 0. 7	--

Notes:

*)U.S.L.: Upper Standard Level

**)L.S.L.: Lower Standard Level

Precautions

1.Storage

Under the storage conditions of 30°C or less and humidity less than 60%RH, the LEDs can be storage for 3months. Storage in a sealed container with moisture absorbent material can prolong the storage time to a certain extent bad storage conditions may cause the lead frames to corrode or degradation of LED characteristics. It is recommended that the LEDs be used as soon as possible.

2. Static electricity

Static electricity of surge voltage damages the LED .Damaged LED will show some unusual chrematistics such as the forward voltage becomes lower or the LED do not light at the low current even not light. All devices equipment and machinery must be properly grounded. At the same time, it is recommended that wrist Bands or anti-electrostatic gloves anti-electrostatic containers be used when dealing with the LED.

3. Design Consideration

When designing a circuit, the current through each LED must not exceed the absolute maximum rating specified for each LED .In the meanwhile , resistors for protection should be applied otherwise slight voltage shift will cause big current change, bum out may happen.

Thermal Design is paramount important in because heat generation may result in the Characteristics decline, such as brightness decreased, Color changed and so on. Please consider the heat generation of the LED when making the system design.

4. Lead Forming

Any lead forming must be done before soldering, not during or after soldering. When forming leads ,the leads should bent at a point at least 3mm from the base of the expose bulb. Bending at the same point twice or even more should be avoided.

Please use proper tools to hold and bent the leads, do not use the base of the lead frame as a fulcrum during lead forming .Bending stress to the base of the lead frame may cause characteristics change on LED or even break it.

Just for the same reason, when mounting the LED on to printed circuit board, the holes on the circuit board should be exactly aligned with the leads of the LED.

5. Soldering

Be careful because damages always caused during soldering. Please note that stress to the leads and expose bulb should be avoided during soldering particularly when heated. When soldering, leave certain distance from soldering joint to base, the distance is determined by different soldering techniques. It is recommended that soldering be performed based on the following conditions.

Recommended Soldering Conditions:

DIP Soldering		Hand Soldering	
Pre-Heat	100°C Max.60 sec.Max	Temperature	350°C Max
Dipping Time	260°C Max.5 secMax	Soldering Time	3 Sec. Max
Dipping Position	2mm ,Min From soldering joint to base	Soldering Position	2mm ,Min From soldering joint to base