

SPECIFICATIONS FOR LED DISPLAYS

14.2mm(0.56") Seven Segments Single Digit

LSD056 -10 Series

WENRUN OPTOELECTRONIC

Features:

- High efficiency, low power consumption.
- Extremely low current.
- Luminous evenly distributed on each segment.
- Low development cost.

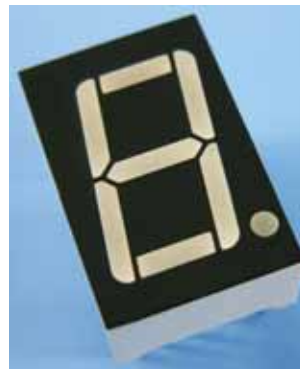
**LSD056A/B -10****Descriptions:**

- Industrial standard size.
- These display provide excellent reliability in bright ambient light.
- These devices are made with white segments and black surface.

Applications:

- Audio equipment or Instrument panels.
- General use for digital indicators.
- Multimedia product.

Selection Guide:

Part No.		Chip		Lens Color
Anode	Cathode	Material	Emitting Color	
LSD056BSR-10	LSD056ASR-10	GaAlAs	Super Red	White Diffused
LSD056BG-10	LSD056AG-10	GaP	Green	
LSD056BY-10	LSD056AY-10	GaAsP/GaP	Yellow	

Absolute Maximum Rating (Ta=25)

Parameter	Symbol	Super Red	Green	Yellow	Unit
Power Dissipation/Segment	P _d	50	60	60	mW
Peak Forward Current /Segment (Duty 1/10@ 1KHz)	I _{FP}	70	70	70	mA
Continuous Forward Current /Segment	I _F	20	20	20	mA
Recommend use current /Segment	I _F	5~10	5~10	5~10	mA
Reverse Voltage /Segment	V _R	5	5	5	V
Operating Temperature Range	Topr	-25~ +75			
Storage Temperature Range	Tstg	-30 ~ +85			
Solder Temperature	Tsol	260 ± 5			

- Notes :** 1、 This is the limit current . It is not allowed to use when the product work continuously.
 2、 It is recommended that the product is driven by TTL,CMOS.
 3、 Soldering time 5 seconds.

Electrical Optical Characteristics (Ta=25)

Parameter	Symbol	Super Red		Green		Yellow		Unit	Test Condition
		Typ.	Max.	Typ.	Max.	Typ.	Max.		
Luminous Intensity /Segment	I _v	9.5	--	4.8	--	4.8	--	mcd	I _F =10mA
Forward Voltage /Segment	V _F	1.85	2.3	2.2	2.5	2.0	2.5	V	I _F =20mA
Reverse Current /Segment	I _R	--	50	--	50	--	50	uA	V _R =5V
Dominant Wavelength	d	645	--	565	--	585	--	nm	I _F =20mA
Spectral Line Half Width		30	--	30	--	30	--	nm	I _F =20mA

Package Dimensions:

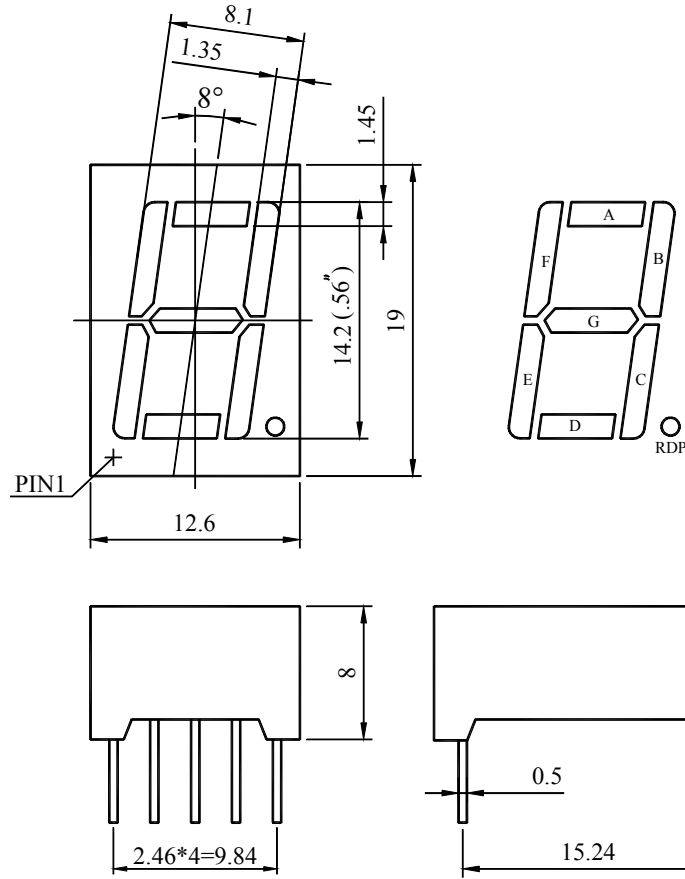

NOTES :

- All dimensions are in millimetres (mm), Tolerance is $\pm 0.25\text{mm}$ unless otherwise noted.
- Specifications are subject to change without notice.

Internal Circuit:

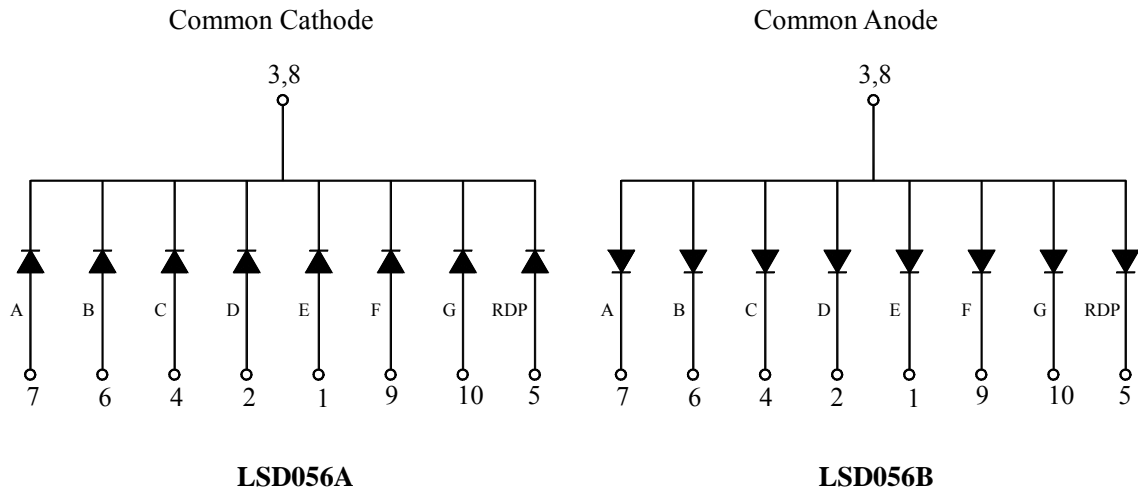

Reliability Test Items and Conditions

NO	Test Item	Test Conditions	Duration	Sample	Ac/Re
1	Temperature Cycle	-30 ~ 25 ~ 85 ~ 25 30min 5min 30min 5min	50cycles	100	0/1
2	High Temp. Storage	Ta=85	1000hours	100	0/1
3	Temp.& Humidity Test	Ta=85 RH=85%	1000hours	100	0/1
4	Low Temp. Storage	Ta=-30	1000hours	100	0/1
5	Operating Life Test	Ta=25 ± 5 DC IF=15mA	1000hours	100	0/1
6	Solder Heat	Tsol=260 ± 5 , 10s	1times	20	0/1

Typical Electro-Optical Characteristics Curves

