

型号 (Type) : HY 40 A 12 TR 09 - 1

	1	2	3	4	5	6	7
1 华宇电子							
2 标称频率							
3 外壳材质							
4 外壳直径							
5 功能							
6 产品高度							
7 结构							



### 电气规格(ELECTRICAL SPECIFICATION)

- 功能 (Function) : Dual use (双用途)
- 结构 (structure) : Open Structure (开放式)
- 外壳材质 (Housing Material) : Aluminum (铝)
- 中心频率 (Center Frequency) :  $40 \pm 1.5$  KHz
- 静态电容 (Free Capacitance) :  $2300\text{Pf} \pm 20\%$
- 声压 (Sound Pressure Level) : 110dB min. (0dB=0.02mPa)
- 灵敏度 (Sensitive) : -70dB Min (0dB=1V/ $\mu$  bar)
- 发射角度 (-6 dB Directivity (deg) :  $90^\circ \pm 15^\circ$
- 使用温度 (Operating Temperature) :  $-30^\circ\text{C} \sim +70^\circ\text{C}$
- 最大允许电压 (Maximum allowable voltage) : 80Vp-p
- 储存温度 (Storage Temperature) :  $-40^\circ\text{C} \sim +80^\circ\text{C}$
- 余震 (Ringing) : 2.0ms MAX
- 重量 (Weight) : 1.5g

### 外观及尺寸 (Appearance and size)

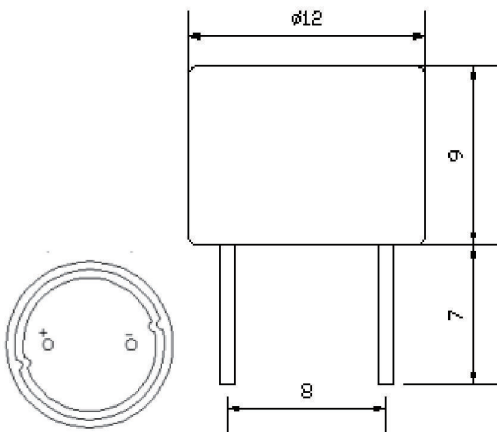

### 性能参数 (graphics for performance parameters)

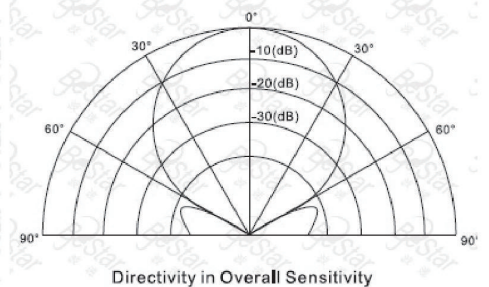
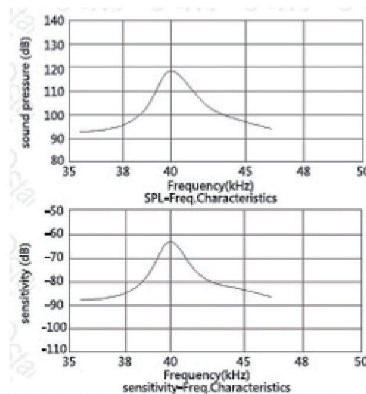

## 测试电路 (Test circuit)

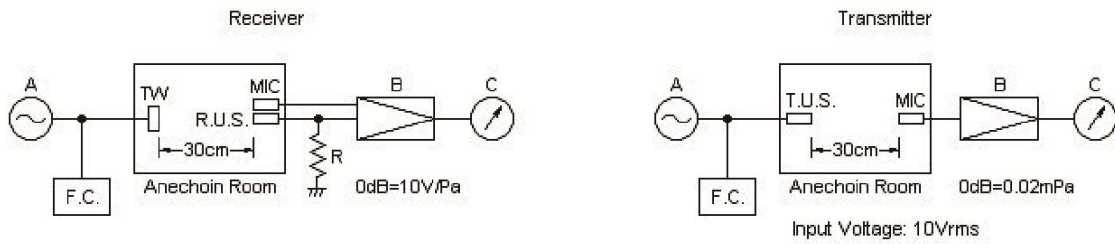

A: Oscillator B: Amplifier C: Voltmeter R: 3.9K MIC: Microphone TW: Tweeter  
R.U.S.: Receiver Ultrasonic Sensor T.U.S.: Transmitter Ultrasonic Sensor F.C.: Frequency Counter

## 可靠性试验 (RELIABILITY TEST)

### 1 High temp test

After being placed in a chamber at 120°C for 24 hours

### 2 Low temp test

After being placed in a chamber at -30°C for 96 hours

### 3 Humidity Test

After being placed in a chamber +50°C and 90±5% relative Humidity for 96 hours

### 4 Vibration

Sensor shall be measured after being applied vibration of Amplitude of 1.5mm with 10 to 55hz band of vibration frequency to each of 3 per-pendicular directions for 2 hours

### 5 Drop test

The part only shall be dropped from a height of 100cm onto a 10mm thick wooden board 3 times in 3 axes(X.Y.Z). (a total of 9 times).

### 6 Treminal Mechanical strength

The force 10 seconds of 9.8N(1.0Kg) is applied to each terminal in axial direction  
No damage and cutting off

7 After the test the part shall meet specifications with-out any Degradation in appearance and performance except SPL after 4 hours at 25°C. The SPL should be in±10dB compared wit initial one.

### 1 高温试验

120 度放置 24 小时

### 2 低温试验

30 度放置 96 小时

### 3 湿度测试

50 度 90±5%，96 小时。

### 4 振动

10-55hz 1min 1.5mm 3 轴 (x.y.z) 2hours/direction

### 5 跌落试验

100CM高下落到10mm厚的木板上3次一个循环（共做9次）。

### 6 接线的机械强度

用力 10 秒 9.8n (1.0kg) 施加到终端，在轴向方无损坏切断。

7 试验结束后，在 25°C4 小时后，传感器的外观和性能均应符合规定。声压级应在±10db相比初始。

## 包装规范 (Package Specification)

1 每只泡沫盒 100 只产品。

Each foam box has 100 products

2 每箱 40 只泡沫盒。

40 foam boxes in each case

3 每箱 4000 只产品。

4000 products per carton

4 包装箱尺寸 505X420X280 (mm)

Packing case size 505X420X280 mm

