

# GSM Antenna AN123

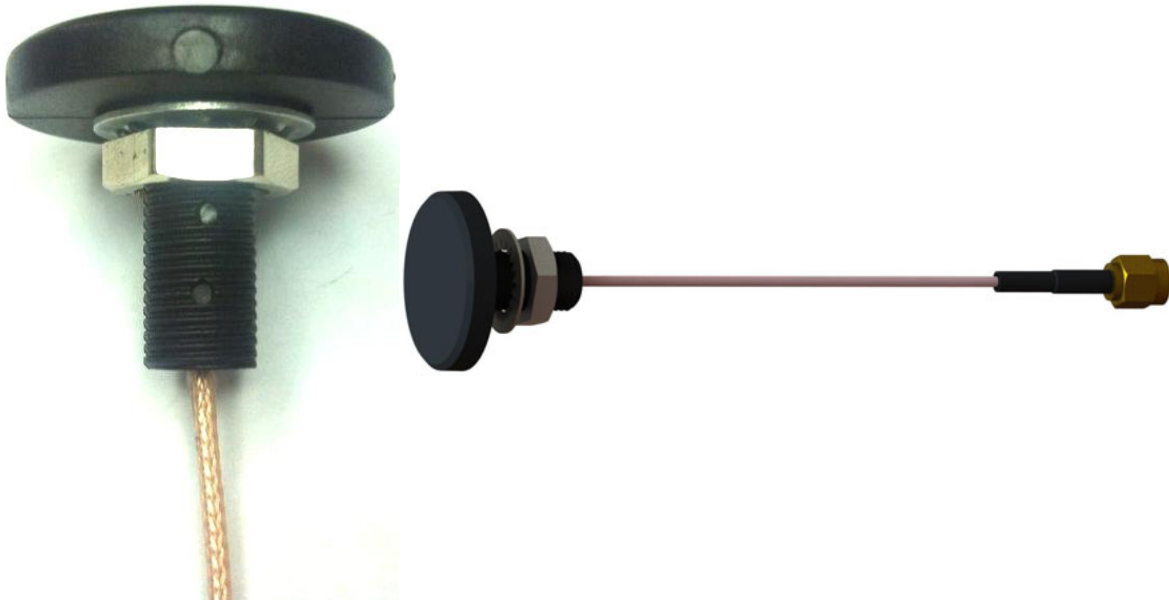

## DIMENSIONS

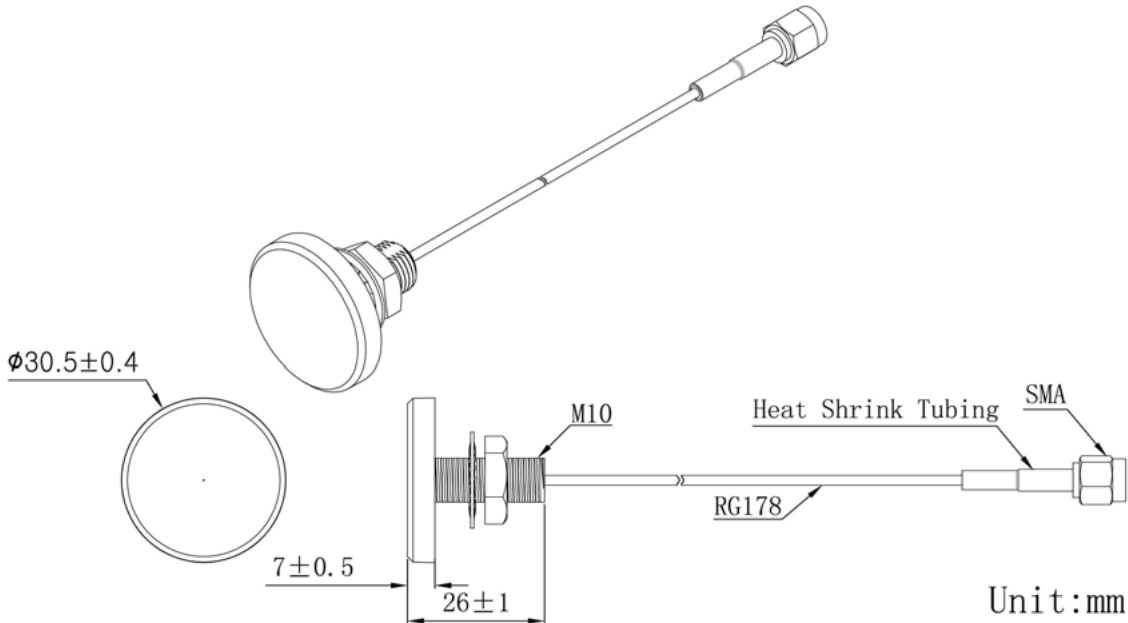

## SPECIFICATIONS

Item		Specifications
GSM Antenna	Frequency Range	824~960MHz/1710~2170MHz
	Polarization	Linear
	Gain	0.5dBi (Zenith)
	V.S.W.R(min)	<2.0
	Impedance	50Ω
Mechanical	Cable	RG 178 3M
	Connector	SMA Male
	Radome Material	ABS
	Mounting Method	Screw
Environmental	Operating Temperature	-40°C ~+85°C
	Relative Humidity	Up to 95%
	Ingress Protection	IP68
	Vibration	10 to 55Hz with 1.5mm amplitude 2hours
	Environmentally Friendly	ROHS Compliant

## Radiation Pattern

