

CMOSTEK

Features

- Embedded EEPROM
 - Very Easy Development with RFPDK
 - All Features Programmable
- Frequency Range: 300 to 480 MHz
- Symbol Rate: 0.1 to 40 kbps
- Sensitivity: -114 dBm at 1 kbps, 0.1% BER
- 3-wire SPI Interface for EEPROM Programming
- Stand-Alone, No External MCU Control Required
- Configurable Duty-Cycle Operation Mode
- Supply Voltage: 1.8 to 3.6 V
- Low Power Consumption: 3.8 mA
- Low Sleep Current
 - 60 nA when Sleep Timer Off
 - 440 nA when Sleep Timer On
- RoHS Compliant
- 16-pin QFN 3x3 Package

Descriptions

The CMT2210A is an ultra low power, high performance, low-cost OOK stand-alone RF receiver for various 300 to 480 MHz wireless applications. It is part of the CMOSTEK NextGenRF™ family, which includes a complete line of transmitters, receivers and transceivers. An embedded EEPROM allows the frequency, symbol rate and other features to be programmed into the device using the CMOSTEK USB Programmer and RFPDK. Alternatively, in stock products of 315/433.92 MHz are available for immediate demands with no need of EEPROM programming. When the CMT2210A is always on, it consumes only 3.8 mA current while achieving -114 dBm receiving sensitivity. It consumes even less power when working in duty-cycle operation mode via the built-in sleep timer. The CMT2210A receiver together with the CMT211x transmitter enables an ultra low cost RF link.

Applications

- Low-Cost Consumer Electronics Applications
- Home and Building Automation
- Infrared Receiver Replacements
- Industrial Monitoring and Controls
- Remote Automated Meter Reading
- Remote Lighting Control System
- Wireless Alarm and Security Systems
- Remote Keyless Entry (RKE)

Ordering Information

Part Number	Frequency	Package	MOQ
CMT2210A-EQR	Random	QFN16	5,000 pcs
CMT2210A-EQR3	315 MHz	QFN16	5,000 pcs
CMT2210A-EQR4	433.92 MHz	QFN16	5,000 pcs

More Ordering Info: See [Page 21](#)



QFN16 (3x3)

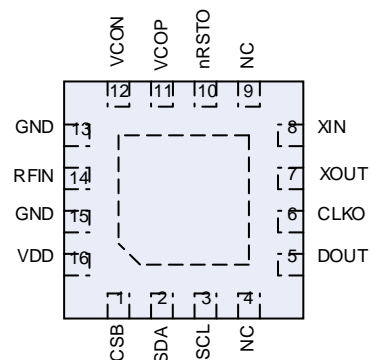

CMT2210A Top View

Typical Application

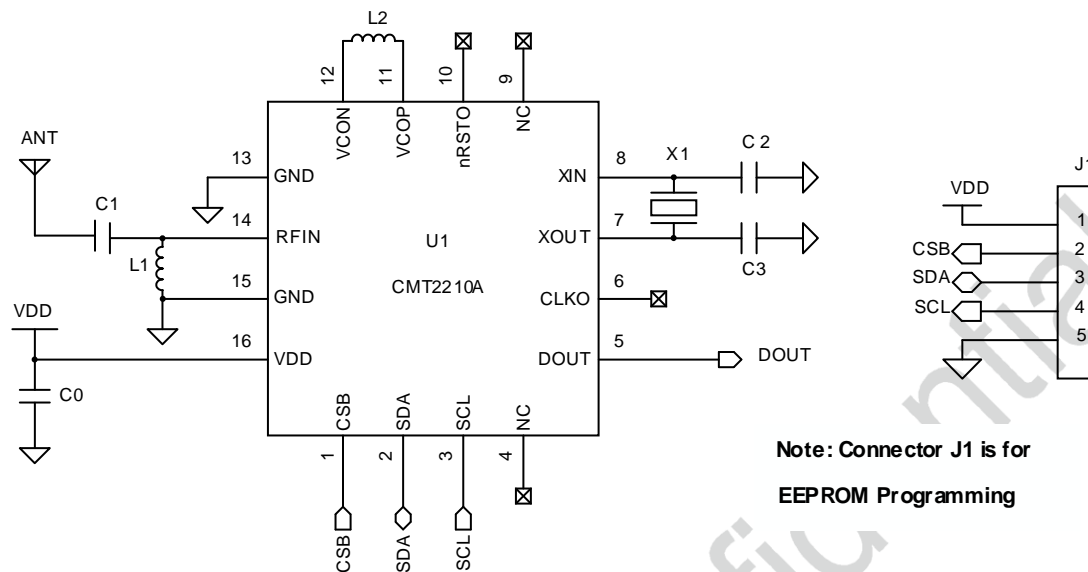

Figure 1. CMT2210A Typical Application Schematic

Table 1. BOM of Typical Application

Designator	Descriptions	Value		Unit	Manufacturer
		315 MHz	433.92 MHz		
U1	CMT2210A, low-cost 300 – 480 MHz OOK stand-alone RF receiver	-		-	CMOSTEK
L1	±5%, 0603 multi-layer chip inductor	39	27	nH	Murata LQG18
L2	±5%, 0603 multi-layer chip inductor	33	22	nH	Murata LQG18
C1	±0.25 pF, 0402 NP0, 50 V	4.3	3.3	pF	Murata GRM15
C0	±20%, 0402 X7R, 25 V	0.1		uF	Murata GRM15
C2, C3	±5%, 0402 NP0, 50 V	15		pF	Murata GRM15
X1	±20 ppm, SMD32*25 mm, crystal	26		MHz	EPSON

Abbreviations

Abbreviations used in this data sheet are described below

AGC	Automatic Gain Control	PC	Personal Computer
AN	Application Notes	PCB	Printed Circuit Board
BER	Bit Error Rate	PLL	Phase Lock Loop
BOM	Bill of Materials	PN9	Pseudorandom Noise 9
BSC	Basic Spacing between Centers	POR	Power On Reset
BW	Bandwidth	PUP	Power Up
DC	Direct Current	QFN	Quad Flat No-lead
EEPROM	Electrically Erasable Programmable Read-Only Memory	RF	Radio Frequency
ESD	Electro-Static Discharge	RFPDK	RF Products Development Kit
ESR	Equivalent Series Resistance	RoHS	Restriction of Hazardous Substances
Ext	Extended	RSSI	Received Signal Strength Indicator
IF	Intermediate Frequency	Rx	Receiving, Receiver
LNA	Low Noise Amplifier	SAR	Successive Approximation Register
LO	Local Oscillator	SPI	Serial Port Interface
LPOSC	Low Power Oscillator	TH	Threshold
Max	Maximum	Tx	Transmission, Transmitter
MCU	Microcontroller Unit	Typ	Typical
Min	Minimum	USB	Universal Serial Bus
MOQ	Minimum Order Quantity	VCO	Voltage Controlled Oscillator
NPO	Negative-Positive-Zero	WOR	Wake On Radio
NC	Not Connected	XOSC	Crystal Oscillator
OOK	On-Off Keying	XTAL/Xtal	Crystal

Table of Contents

1. Electrical Characteristics	5
1.1 Recommended Operation Conditions	5
1.2 Absolute Maximum Ratings	5
1.3 Receiver Specifications	6
1.4 Crystal Oscillator	7
1.5 LPOSC	7
2. Pin Descriptions	8
3. Typical Performance Characteristics	9
4. Typical Application Schematic	10
5. Functional Descriptions	11
5.1 Overview	11
5.2 Modulation, Frequency and Symbol Rate	11
5.3 Embedded EEPROM and RFPDK	12
5.4 All Configurable Options	12
5.5 Internal Blocks Description	14
5.5.1 RF Front-end and AGC	14
5.5.2 IF Filter	14
5.5.3 RSSI	14
5.5.4 SAR ADC	15
5.5.5 Crystal Oscillator	15
5.5.6 Frequency Synthesizer	15
5.5.7 LPOSC	16
5.6 Operation Mode	16
5.7 Always Receive Mode	17
5.8 Duty-Cycle Receive Mode	17
5.9 Easy Duty-Cycle Configurations	18
5.10 The nRSTO	19
5.11 The CLKO	20
6. Ordering Information	21
7. Package Outline	22
8. Top Marking	23
8.1 CMT2210A Top Marking	23
9. Other Documentations	24
10. Document Change List	25
11. Contact Information	26

1. Electrical Characteristics

$V_{DD} = 3.3\text{ V}$, $T_{OP} = 25\text{ }^{\circ}\text{C}$, $F_{RF} = 433.92\text{ MHz}$, sensitivities are measured in receiving a PN9 sequence and matching to $50\text{ }\Omega$ impedance, with the BER of 0.1%. All measurements are performed using the board CMT2210A-EM V1.0, unless otherwise noted.

1.1 Recommended Operation Conditions

Table 2. Recommended Operation Conditions

Parameter	Symbol	Conditions	Min	Typ	Max	Unit
Operation Voltage Supply	V_{DD}		1.8		3.6	V
Operation Temperature	T_{OP}		-40		85	$^{\circ}\text{C}$
Supply Voltage Slew Rate			1			mV/us

1.2 Absolute Maximum Ratings

Table 3. Absolute Maximum Ratings^[1]

Parameter	Symbol	Conditions	Min	Max	Unit
Supply Voltage	V_{DD}		-0.3	3.6	V
Interface Voltage	V_{IN}		-0.3	$V_{DD} + 0.3$	V
Junction Temperature	T_J		-40	125	$^{\circ}\text{C}$
Storage Temperature	T_{STG}		-50	150	$^{\circ}\text{C}$
Soldering Temperature	T_{SDR}	Lasts at least 30 seconds		255	$^{\circ}\text{C}$
ESD Rating ^[2]		Human Body Model (HBM)	-2	2	kV
Latch-up Current		@ $85\text{ }^{\circ}\text{C}$	-100	100	mA

Notes:

- [1]. Stresses above those listed as “absolute maximum ratings” may cause permanent damage to the device. This is a stress rating only and functional operation of the device under these conditions is not implied. Exposure to maximum rating conditions for extended periods may affect device reliability.
- [2]. The CMT2210A is high-performance RF integrated circuits with VCON/P pins having an ESD rating $< 2\text{ kV}$ HBM. Handling and assembly of this device should only be done at ESD-protected workstations.

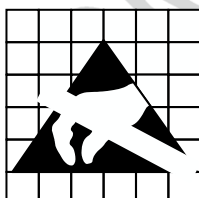

Caution! ESD sensitive device. Precaution should be used when handling the device in order to prevent permanent damage.

1.3 Receiver Specifications

Table 4. Receiver Specifications

Parameter	Symbol	Conditions	Min	Typ	Max	Unit
Frequency Range	F_{RF}		300		480	MHz
Symbol Rate	SR		0.1		40	kbps
Sensitivity	S_{315}	$F_{RF} = 315 \text{ MHz}$, SR = 1 kbps, BER = 0.1%		-114		dBm
	$S_{433.92}$	$F_{RF} = 433.92 \text{ MHz}$, SR = 1 kbps, BER = 0.1%		-113		dBm
Saturation Input Signal Level	P_{LVL}			10		dBm
Working Current	I_{DD}	$F_{RF} = 315 \text{ MHz}$		3.5		mA
		$F_{RF} = 433.92 \text{ MHz}$		3.8		mA
Sleep Current	I_{SLEEP}	When sleep timer is on		440		nA
		When sleep timer is off		60		nA
Frequency Resolution	F_{RES}			24.8		Hz
Frequency Synthesizer Settle Time	T_{LOCK}	From XOSC settled		150		us
Blocking Immunity	BI	SR = 1 kbps, $\pm 1 \text{ MHz}$ offset, CW interference		52		dB
		SR = 1 kbps, $\pm 2 \text{ MHz}$ offset, CW interference		74		dB
		SR = 1 kbps, $\pm 10 \text{ MHz}$ offset, CW interference		75		dB
Image Rejection Ratio	IMR	IF = 280 kHz		35		dB
Input 3 rd Order Intercept Point	IIP3	Two tone test at 1 MHz and 2 MHz offset frequency. Maximum system gain settings		-25		dBm
Receiver Bandwidth	BW		50		500	kHz
Receiver Start-up Time	$T_{START-UP}$	From power up to receive, in Always Receive Mode		4.3		ms
Receiver Wake-up Time	$T_{WAKE-UP}$	From sleep to receive, in Duty-Cycle Receive Mode		0.61		ms

1.4 Crystal Oscillator

Table 5. Crystal Oscillator Specifications

Parameter	Symbol	Conditions	Min	Typ	Max	Unit
Crystal Frequency ^[1]	F _{XTAL}		26	26	26	MHz
Crystal Tolerance ^[2]				±20		ppm
Load Capacitance	C _{LOAD}		10	15	20	pF
Crystal ESR	R _m				60	Ω
XTAL Startup Time ^[3]	t _{XTAL}			400		us

Notes:

[1]. The CMT2210A can directly work with external 26 MHz reference clock input to XIN pin (a coupling capacitor is required) with peak-to-peak amplitude of 0.3 to 0.7 V.

[2]. This is the total tolerance including (1) initial tolerance, (2) crystal loading, (3) aging, and (4) temperature dependence. The acceptable crystal tolerance depends on RF frequency and channel spacing/bandwidth.

[3]. This parameter is to a large degree crystal dependent.

1.5 LPOSC

Table 6. LPOSC Specifications

Parameter	Symbol	Conditions	Min	Typ	Max	Unit
Calibrated Frequency ^[1]	F _{LPOSC}			1		kHz
Frequency Accuracy		After calibration		1		%
Temperature Coefficient ^[2]				-0.02		%/°C
Supply Voltage Coefficient ^[3]				+0.5		%/V
Initial Calibration Time	t _{LPOSC-CAL}			4		ms

Notes:

[1]. The LPOSC is automatically calibrated to the crystal oscillator during the PUP state, and is periodically calibrated since then.

[2]. Frequency drifts when temperature changes after calibration. [3]. Frequency drifts when supply voltage changes after calibration.

2. Pin Descriptions

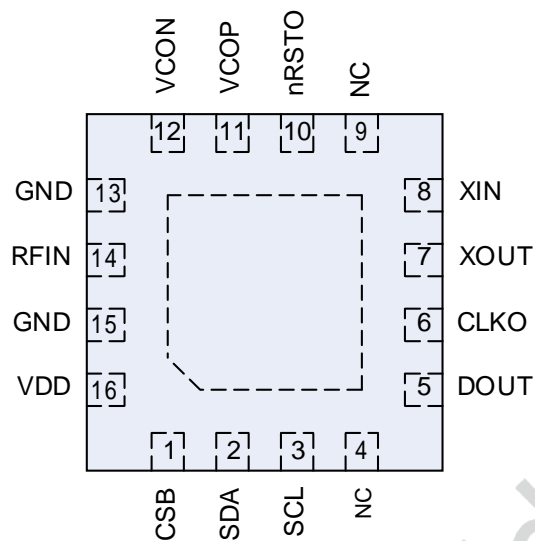

Figure 2. CMT2210A Pin Assignments

Table 7. CMT2210A Pin Descriptions

Pin Number	Name	I/O	Descriptions
1	CSB	I	3-wire SPI chip select input for EEPROM programming
2	SDA	IO	3-wire SPI data input and output for EEPROM programming
3	SCL	I	3-wire SPI clock input for EEPROM programming
4,9	NC	NA	Not connected, leave floating
5	DOUT	O	Received data output
6	CLKO	O	Programmable clock output to drive an external MCU
7	XOUT	O	Crystal oscillator output
8	XIN	I	Crystal oscillator input or external reference clock input
10	nRSTO	O	Active-low power-on-reset output to reset an external MCU
11	VCOP	IO	VCO tank, connected to an external inductor
12	VCON		
13, 15	GND	I	Ground
14	RFIN	I	RF signal input to the LNA
16	VDD	I	Power supply input

3. Typical Performance Characteristics

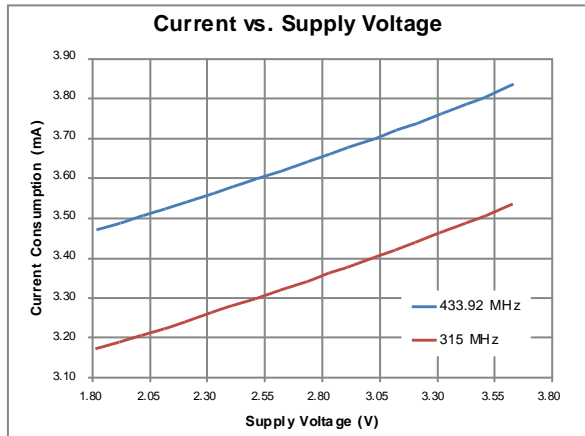

Figure 3.1 Current vs. Voltage, $F_{RF} = 315 / 433.92$ MHz, SR = 1 kbps

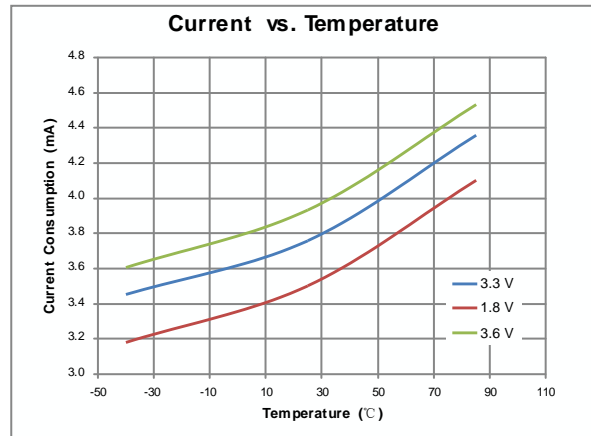

Figure 3.2 Current vs. Temperature, $F_{RF} = 433.92$ MHz, SR = 1 kbps

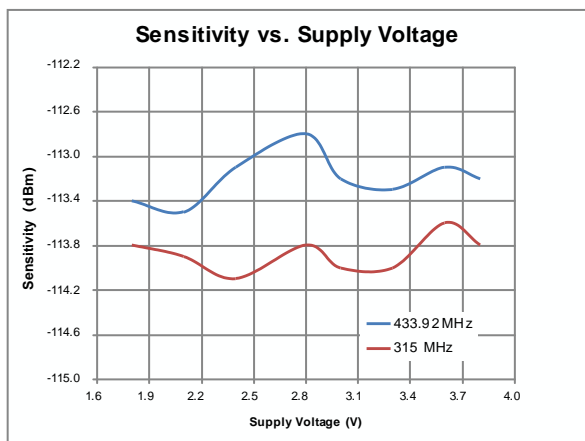

Figure 3.3 Sensitivity vs. Supply Voltage, SR = 1 kbps, BER = 0.1 %

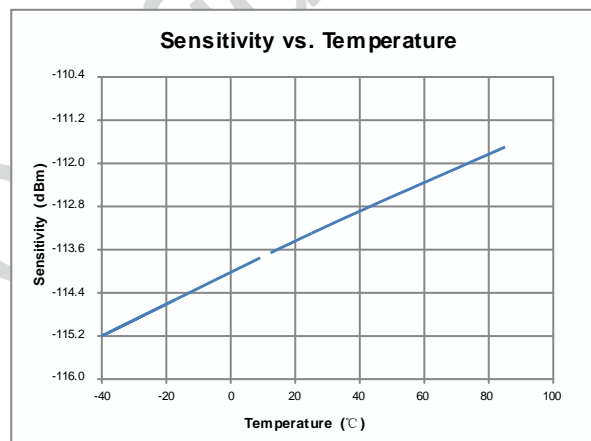

Figure 3.4 Sensitivity vs. Temperature, $F_{RF} = 433.92$ MHz, $V_{DD} = 3.3$ V, SR = 1 kbps, BER = 0.1 %

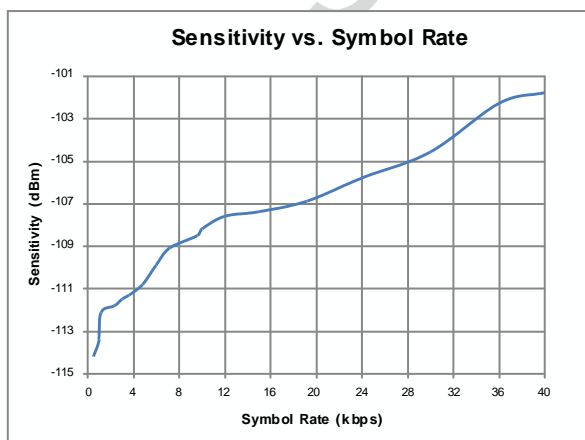

Figure 3.5 Sensitivity vs. SR, $F_{RF} = 433.92$ MHz, $V_{DD} = 3.3$ V, BER = 0.1 %

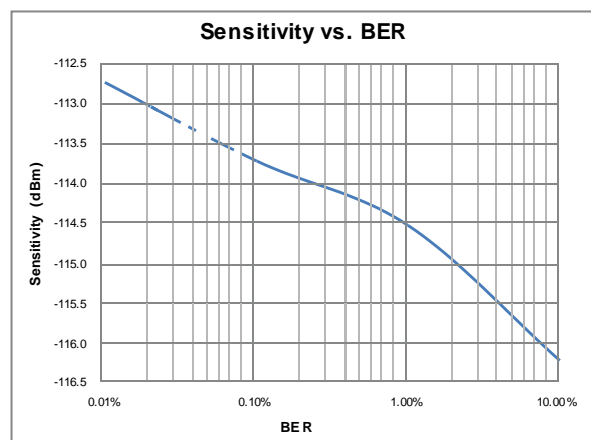

Figure 3.6 Sensitivity vs. BER, $F_{RF} = 433.92$ MHz, $V_{DD} = 3.3$ V, SR = 1 kbps

4. Typical Application Schematic

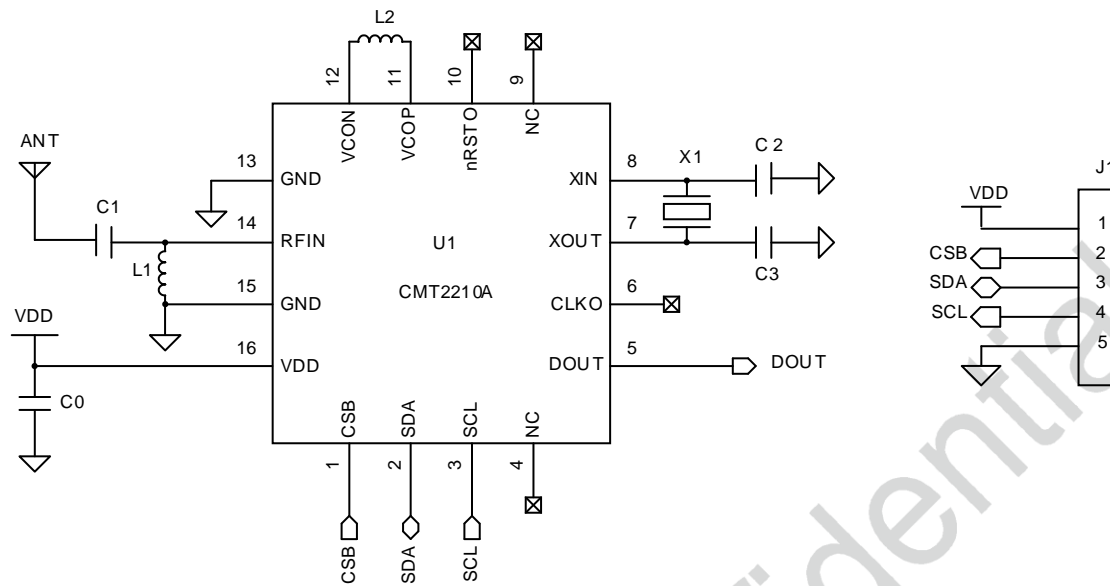

Figure 4. Typical Application Schematic

Notes:

1. Connector J1 is a must for the CMT2210A EEPROM access during development or manufacture.
2. The general layout guidelines are listed below. For more design details, please refer to “AN107 CMT2210A Schematic and PCB Layout Design Guideline”.
 - Use as much continuous ground plane metallization as possible.
 - Use as many grounding vias (especially near to the GND pins) as possible to minimize series parasitic inductance between the ground pour and the GND pins.
 - Avoid using long and/or thin transmission lines to connect the components.
 - Place C0 as close to the CMT2210A as possible for better filtering.
3. Table 8 shows the BOM of typical application.

Table 8. BOM of Typical Application

Designator	Descriptions	Value		Unit	Manufacturer
		315 MHz	433.92 MHz		
U1	CMT2210A, low-cost 300 – 480 MHz OOK stand-alone RF receiver	-		-	CMOSTEK
L1	±5%, 0603 multi-layer chip inductor	39	27	nH	Murata LQG18
L2	±5%, 0603 multi-layer chip inductor	33	22	nH	Murata LQG18
C1	±0.25 pF, 0402 NP0, 50 V	4.3	3.3	pF	Murata GRM15
C0	±20%, 0402 X7R, 25 V	0.1		uF	Murata GRM15
C2, C3	±5%, 0402 NP0, 50 V	15		pF	Murata GRM15
X1	±20 ppm, SMD32*25 mm, crystal	26		MHz	EPSON

5. Functional Descriptions

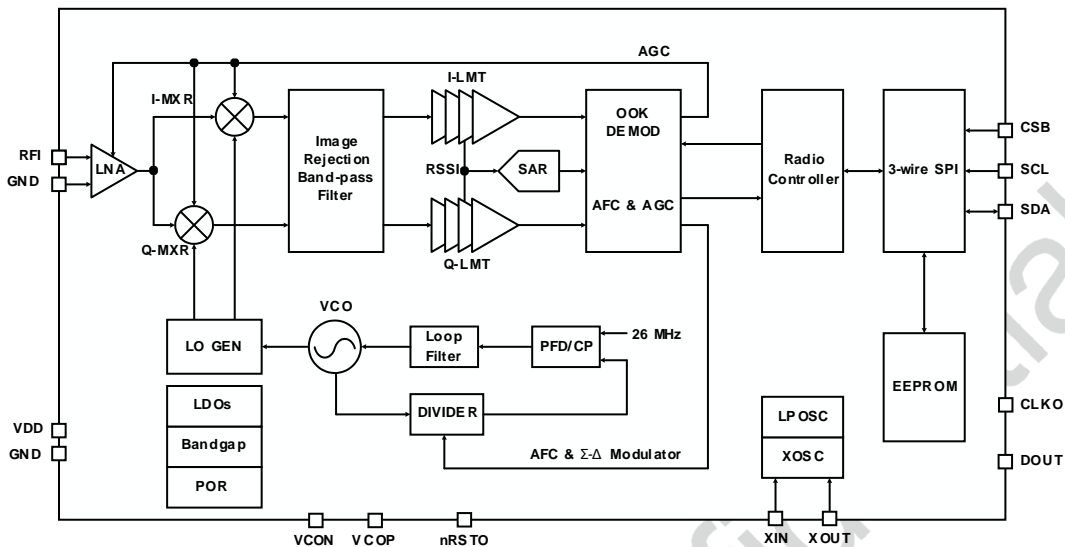

Figure 5. Functional Block Diagram

5.1 Overview

The CMT2210A is an ultra low power, high performance, low-cost OOK stand-alone RF receiver for various 300 to 480 MHz wireless applications. It is part of the CMOSTEK NextGenRF™ family, which includes a complete line of transmitters, receivers and transceivers. The chip is based on a fully integrated, low-IF receiver architecture. The low-IF architecture facilitates a very low external component count and does not suffer from powerline - induced interference problems. The synthesizer contains a VCO and a low noise fractional-N PLL with an output frequency resolution of 24.8 Hz. The VCO operates at 2x the Local Oscillator (LO) frequency to reduce spurious emissions. Every analog block is calibrated on each Power-on Reset (POR) to the internal reference voltage. The calibration helps the device to finely work under different temperatures and supply voltages. The baseband filtering and demodulation is done by the digital demodulator. The demodulated signal is output to the external MCU via the DOUT pin. No external MCU control is needed in the applications.

The 3-wire SPI interface is only used for configuring the device. The configuration can be done with the RFPDK and the USB Programmer. The RF Frequency, symbol rate and other product features are all configurable. This saves the cost and simplifies the design, development and manufacture. Alternatively, in stock products of 315/433.92 MHz are available for immediate demands with no need of EEPROM programming. The CMT2210A operates from 1.8 to 3.6 V so that it can finely work with most batteries to their useful power limits. The receive current is only 3.8 mA. The CMT2210A receiver together with the CMT211x transmitter enables an ultra low cost RF link.

5.2 Modulation, Frequency and Symbol Rate

The CMT2210A supports OOK demodulation with the symbol rate from 0.1 to 40 kbps. It continuously covers the frequency range from 300 to 480 MHz, including the license free ISM frequency band around 315 MHz and 433.92 MHz. The internal frequency synthesizer contains a high-purity VCO and a low noise fractional-N PLL with an

output frequency resolution of 24.8 Hz. See Table 9 for the demodulation, frequency and symbol rate information.

Table 9. Modulation, Frequency and Symbol Rate

Parameter	Value	Unit
Demodulation	OOK	-
Frequency	300 to 480	MHz
Frequency Resolution	24.8	Hz
Symbol Rate	0.1 to 40	kbps

5.3 Embedded EEPROM and RFPDK

The RFPDK is a PC application developed to help the user to configure the CMOSTEK NextGenRF™ products in the most intuitional way. The user only needs to connect the USB Programmer between the PC and the device, fill in/select the proper value of each parameter on the RFPDK, and click the “Burn” button to program the configurations into the device. The configurations of the device will then remain unchanged until the next programming. No external MCU control is required in the application program.

The RFPDK also allows the user to save the active configuration into a list by clicking on the “List” button, so that the saved configuration can be directly reloaded from the list in the future. Furthermore, it supports exporting the configuration into a hexadecimal file by clicking on the “Export” button. This file can be used to burn the same configuration into a large amount of devices during the mass production. See Figure 6 for the accessing of the EEPROM.

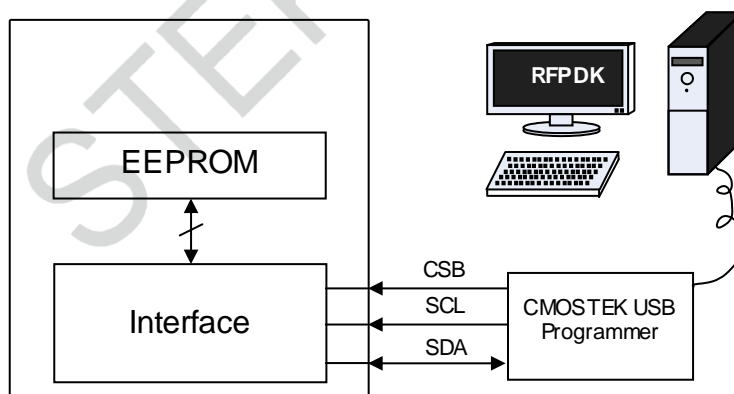

Figure 6. Accessing Embedded EEPROM

For more details of the CMOSTEK USB Programmer and the RFPDK, please refer to “AN103 CMT2110A/2210A One-Way RF Link Development Kits”.

5.4 All Configurable Options

Beside the demodulation, frequency and symbol rate, more options can be used to customize the device. The following is a table of all the configurable options. On the RFPDK, the Basic Mode only contains a few options

allowing the user to perform easy and fast configurations. The Advanced Mode shows all the options that allow the user to customize the device in a deeper level. The options in “Basic Mode” are a subset of that in the “Advanced Mode”.

Table 10. Configurable Parameters in RFPDK

Category	Parameters	Descriptions	Default	Mode
RF Settings	Frequency	The receive radio frequency, the range is from 300 to 480 MHz, with resolution of 0.01 MHz.	433.92 MHz	Basic Advanced
	Demodulation	The demodulation type, only OOK demodulation is supported in this product.	OOK	Basic Advanced
	Symbol Rate	The receiver symbol rate, the range is from 0.1 to 40 kbps, with resolution of 0.1 kbps.	4.8 kbps	Basic Advanced
	Squelch TH	The threshold of the squelch circuit to suppress the noise, the range is from 0 to 255.	0	Basic Advanced
	Xtal Tolerance	Crystal frequency tolerance, the range is from 0 to ± 200 ppm.	± 20 ppm	Basic Advanced
	Xtal Stabilizing Time	Time for the device to wait for the crystal to get settled after power up. The options are: 78, 155, 310, 620, 1240 or 2480 us.	310 us	Basic Advanced
Operation Settings	Duty-Cycle Mode	Turn on/off the duty-cycle receive mode, the options are: on or off.	On	Basic Advanced
	Sleep Time	The sleep time in duty-cycle receive mode, the range is from 3 to 134,152,192 ms.	3 ms	Basic Advanced
	Rx Time	The receive time in duty-cycle receive mode, the range is from 0.04 to 2,683,043.00 ms. The default value is different when the Wake-On Radio (WOR) is turned on or off.	10,000.00 (WOR is off) or 20.00 (WOR is on)	Basic Advanced
	Rx Time Ext	The extended receive time in duty-cycle receive mode, the range is from 0.04 to 2,683,043.00 ms.	200.00 ms	Advanced
	Wake-On Radio	Turn on/off the wake-on radio function, the options are: on or off.	Off	Advanced
	Wake-On Condition	The condition to wake on the radio, the options are: Extended by Preamble, or Extended by RSSI	Extended by Preamble	Advanced
	System Clock Output	Turn on/off the system clock output on CLKO, the options are: on or off.	Off	Advanced
	System Clock Frequency	The system clock output frequency, the options are: 13.000, 6.500, 4.333, 3.250, 2.600, 2.167, 1.857, 1.625, 1.444, 1.300, 1.182, 1.083, 1.000, 0.929, 0.867, 0.813, 0.765, 0.722, 0.684, 0.650, 0.619, 0.591, 0.565, 0.542, 0.520, 0.500, 0.481, 0.464, 0.448, 0.433, 0.419 or 0.406 MHz.	6.5 MHz	Advanced

Category	Parameters	Descriptions	Default	Mode
OOK Settings	Demod Method	The OOK demodulation methods, the options are: Peak TH, or Fixed TH	Peak TH	Advanced
	Fixed Demod TH	The threshold value when the Demod Method is "Fixed TH", the minimum input value is the value of Squelch Threshold set on the RFPDK, the maximum value is 255.	80	Advanced
	Peak Drop	Turn on/off the RSSI peak drop function, the options are on, or off.	On	Advanced
	Peak Drop Step	The RSSI peak drop step, the options are: 1, 2, 3, 5, 5, 9, 12 or 15.	2	Advanced
	Peak Drop Rate	The RSSI peak drop rate, the options are: 1 step/4 symbol, 1 step/2 symbol, 1 step /1 symbol, or 1 step/0.5 symbol.	1 step / 4 symbol	Advanced
Decode Settings	Preamble	The size of the valid preamble, the options are: 1-byte, 2-byte, 3-byte, or 4-byte	2-byte	Advanced

5.5 Internal Blocks Description

5.5.1 RF Front-end and AGC

The CMT2210A features a low-IF receiver. The RF front-end of the receiver consists of a Low Noise Amplifier (LNA), I/Q mixer and a wide-band power detector. Only a low-cost inductor and a capacitor are required for matching the LNA to any 50 Ω antennas. The input RF signal induced on the antenna is amplified and down-converted to the IF frequency for further processing.

By means of the wide-band power detector and the attenuation networks built around the LNA, the Automatic Gain Control (AGC) loop regulates the RF front-end's gain to get the best system linearity, selectivity and sensitivity performance, even though the receiver suffers from strong out-of-band interference.

5.5.2 IF Filter

The signals coming from the RF front-end are filtered by the fully integrated 3rd-order band-pass image rejection IF filter which achieves over 35 dB image rejection ratio typically. The IF center frequency is dynamically adjusted to enable the IF filter to locate to the right frequency band, thus the receiver sensitivity and out-of-band interference attenuation performance are kept optimal despite the manufacturing process tolerances. The IF bandwidth is automatically computed according to the three basic system parameters input from the RFPDK: RF frequency, Xtal tolerance, and symbol rate.

5.5.3 RSSI

The subsequent multistage I/Q Log amplifiers enhance the output signal from IF filter before it is fed for demodulation. Receive Signal Strength Indicator (RSSI) generators are included in both Log amplifiers which produce DC voltages that are directly proportional to the input signal level in both of I and Q path. The resulting RSSI is a sum of both these two paths. Extending from the nominal sensitivity level, the RSSI achieves over 66 dB

dynamic range.

The CMT2210A integrates a patented DC-offset cancellation engine. The receiver sensitivity performance benefits a lot from the novel, fast and accurate DC-offset removal implementation.

5.5.4 SAR ADC

The on-chip 8-bit SAR ADC digitalizes the RSSI for OOK demodulation.

5.5.5 Crystal Oscillator

The crystal oscillator is used as the reference clock for the PLL frequency synthesizer and system clock for the digital blocks. A 26 MHz crystal should be used with appropriate loading capacitors (C2 and C3 in Figure 4, Page 10). The values of the loading capacitors depend on the total load capacitance C_L specified for the crystal. The total load capacitance seen between the XIN and XOUT pin should equal C_L for the crystal to oscillate at 26 MHz.

$$C_L = \frac{1}{\frac{1}{C_2} + \frac{1}{C_3}} + C_{\text{parasitic}}$$

The parasitic capacitance is constituted by the input capacitance and PCB tray capacitance. The ESR of the crystal should be within the specification in order to ensure a reliable start-up (see Section 1.4 on page 7). An external signal source can easily be used in place of a conventional XTAL and should be connected to the XIN pin. The incoming clock signal is recommended to have a peak-to-peak swing in the range of 300 mV to 700 mV and AC-coupled to the XIN pin.

5.5.6 Frequency Synthesizer

A fractional-N frequency synthesizer is used to generate the LO frequency for the down conversion I/Q mixer. The frequency synthesizer is fully integrated except the VCO tank inductor which enables the ultra low-power receiver system design. Using the 26 MHz reference clock provided by the crystal oscillator or the external clock source, it can generate any receive frequency between 300 to 480 MHz with a frequency resolution of 24.8 Hz.

The VCO always operates at 2x of LO frequency. A high Q (at VCO frequency) tank inductor should be chosen to ensure the VCO oscillates at any conditions meanwhile burns less power and gets better phase noise performance. In addition, properly layout the inductor matters a lot of achieving a good phase noise performance and less spurious emission. The recommended VCO inductors for different LO frequency bands are shown as bellow.

Table 11. VCO Inductor for 315/433.92 MHz Frequency Band

LO Frequency Band	315 MHz	433.92 MHz
VCO Inductor	33 nH	22 nH

Multiple subsystem calibrations are performed dynamically to ensure the frequency synthesizer operates reliably in any working conditions.

5.5.7 LPOSC

An internal 1 kHz low power oscillator is integrated in the CMT2210A. It generates a clock to drive the sleep timer to periodically wake the device from sleep state. The Sleep Time can be configured from 3 to 134,152,192 ms (more than 37 hours) when the device works in duty-cycle receive mode. Since the frequency of the LPOSC drifts when the temperature and supply voltage change, it is automatically calibrated during the PUP state, and is periodically calibrated since then. The calibration scheme allows the LPOSC to maintain its frequency tolerance to less than $\pm 1\%$.

5.6 Operation Mode

An option “Duty-Cycle On-Off” on the RFPDK allows the user to determine how the device behaves. The device is able to work in two operation modes, as shown in the figure below.

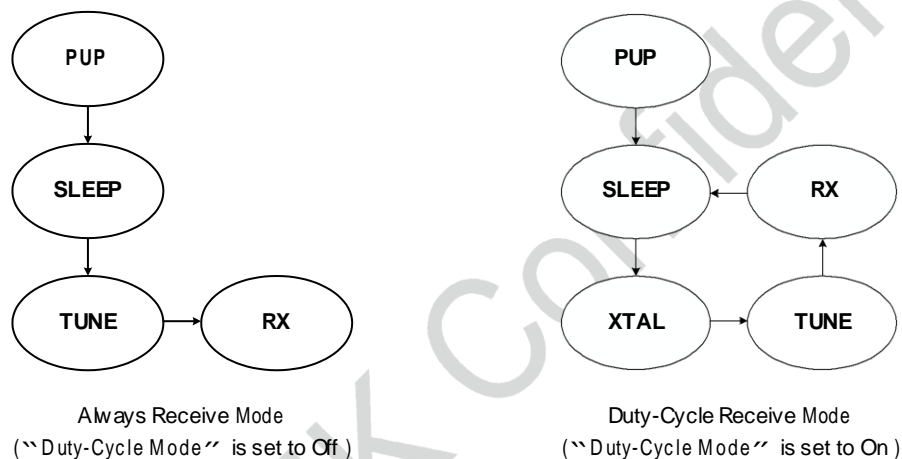

Figure 7. Two different operation modes

Power Up (PUP) State

Once the device is powered up, the device will go through the Power Up (PUP) sequence which includes the task of releasing the Power-On Reset (POR), turning on the crystal and calibrating the internal blocks. The PUP takes about 4 ms to finish in the always receive mode, and about 9.5 ms to finish in the duty-cycle receive mode. This is because that the LPOSC and sleep timer is turned off in the always receive mode, while it must be turned on and calibrated during the PUP in the duty-cycle receive mode. The average current of the PUP sequence is about 0.9 mA.

SLEEP State

In this state, all the internal blocks are powered down except the sleep timer. In Always Receive Mode, the sleep time is fixed at about 3 ms. In Duty-Cycle Receive Mode, the sleep time is defined by the option “Sleep Time” on the RFPDK. The sleep current is about 60 nA in the always receive mode, and about 440 nA (with LPOSC and sleep timer turned on) in the duty-cycle receive mode.

XTAL State

The XTAL state only exists in the duty-cycle receive mode. Once the device wakes up from the SLEEP State, the crystal oscillator restarts to work. The option “XTAL Stabilizing Time” on the RFPDK defines the time for the device

to wait for the crystal oscillator to settle. The current consumption in this state is about 520 μA .

TUNE State

The device is tuned to the desired frequency defined by the option “Frequency” on the RFPDK and ready to receive. It usually takes approximately 300 μs to complete the tuning sequence. The current consumption in this state is about 2 mA.

RX State

The device receives the incoming signals and outputs the demodulated data from the DOUT pin. In duty-cycle receive mode, the device only stays in the RX State for a certain amount of time, which is defined by the option “Rx Time” on the RFPDK. The current in this state is about 3.8 mA.

5.7 Always Receive Mode

If the duty-cycle receive mode is turned off, the device will go through the Power Up (PUP) sequence, stay in the SLEEP state for about 3 ms, tune the receive frequency, and finally stay in the RX state until the device is powered down. The power up sequence, which takes about 4 ms to finish, includes the task of turning on the crystal and calibrating the internal blocks. The device will continuously receive the incoming RF signals during the RX state and send out the demodulated data on the DOUT pin. The configurable system clock is also output from the CLKO pin if it is enabled in the Advanced Mode on the RFPDK. The figure below shows the timing characteristics and current consumption of the device from the PUP to RX.

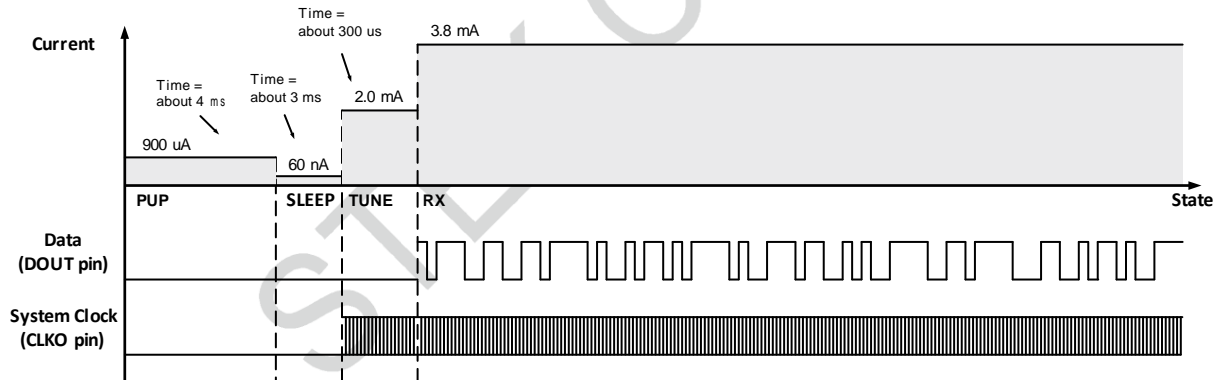

Figure 8. Timing and Current Consumption for Always Receive Mode

5.8 Duty-Cycle Receive Mode

If the duty-cycle mode is turned on, after the PUP the device will automatically repeat the sequence of SLEEP, XTAL, TUNE and RX until the device is powered down. This allows the device to re-tune the synthesizer regularly to adapt to the changeable environment and therefore remain its highest performance. The device will continuously receive any incoming signals during the RX state and send out the demodulated data on the DOUT pin. The configurable system clock output is output from the CLKO pin during the TUNE and RX state. The PUP sequence consumes about 9.5 ms which is longer than the 4 ms in the Always Receive Mode. This is because the LPOSC, which drives the sleep timer, must be calibrated during the PUP.

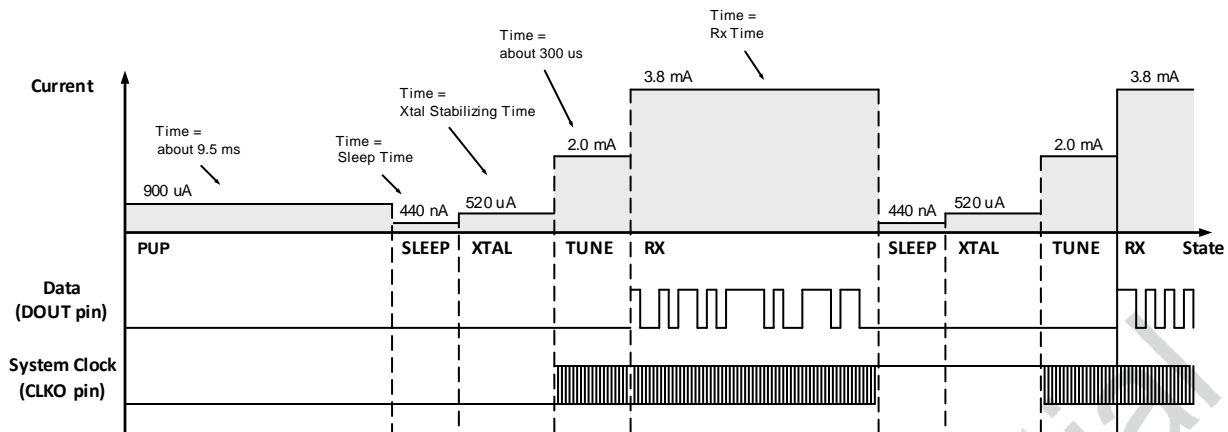

Figure 9. Timing and Current Consumption for Duty-Cycle Receive Mode

It is strongly recommended for the user to turn on the duty-cycle receive mode option. The advantages are:

- Maintaining the highest performance of the device by regular frequency re-tune.
- Increasing the system stability by regular sleep (resetting most of the blocks).
- Saving power consumptions of both of the Tx and Rx device.

As long as the Sleep Time and Rx Time are properly configured, the transmitted data can always be captured by the device.

5.9 Easy Duty-Cycle Configurations

When the user wants to take the advantage of maintaining the highest system stability and performance, and the power consumption is not the first concern in the system, the Easy Configuration can be used to let the device to work in the duty-cycle mode without complex calculations, the following is a good example:

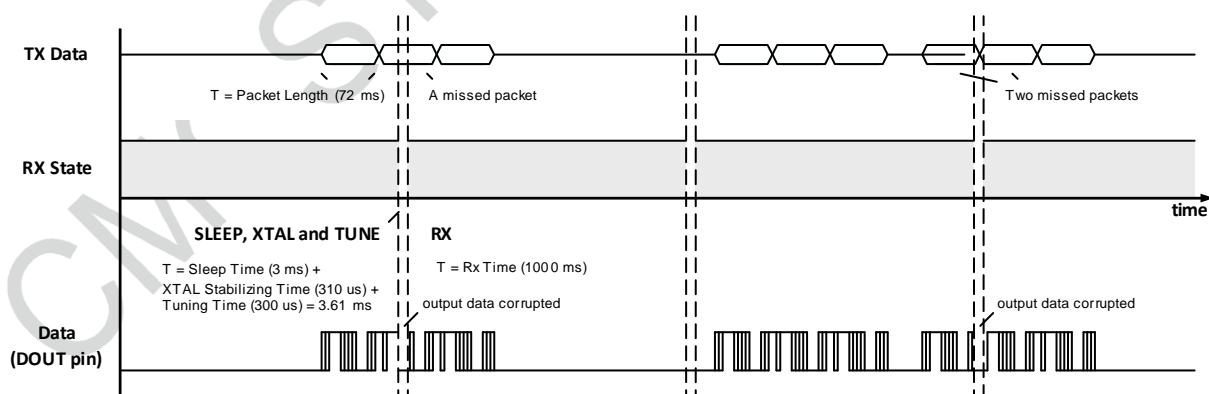

Figure 10. Tx and Rx relationship of Easy Configuration

In this example, the Tx device transmits the data at 1.2 kbps and there are 60 symbols in one data packet. Thus, the packet length is 72 ms. The user can do the following:

- Set the Sleep Time to the minimum value of 3 ms.
- Set the Rx Time to 1 second which is much longer than the packet length.
- Let the Tx device to send out 3 continuous data packets in each transmission.

Because the Sleep Time is very short, the non-receive time is only about 3.61 ms (the sum of the Sleep Time, XTAL stabilizing time and the tuning time), which is much shorter than the packet length of 72 ms. Therefore, this non-receive time period will only have a change to corrupt no more than 2 packets receiving. During the non-receive time period, the DOUT pin will output logic 0.

Because the Rx Time is very long, and 3 continuous data packets are sent in each transmission, there is at least 1 packet that can be completely received by the device and sent out via the DOUT pin with no corruption. The external MCU will only need to observe the DOUT pin status to perform data capturing and further data processing.

If the system power consumption is a sensitive and important factor in the application, the Precise Configuration can be used. Also, based on the duty-cycle receive mode, the “Wake-On Radio” technique allows the device to even save more power. For the precise duty-cycle configurations and the use of wake-on radio, please refer to the “AN108 CMT2210A Configuration Guideline”.

5.10 The nRSTO

By default, an active low reset signal is generated by the internal POR and output via the nRSTO pin. It can be used to reset the external MCU if it is required.

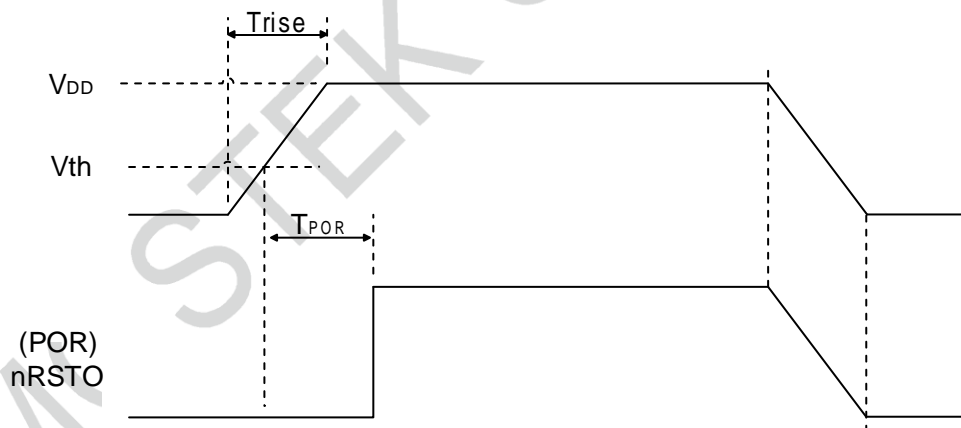

Figure 11. nRSTO Timing Characteristics

On the above figure, T_{rise} is the time taken for the V_{DD} to rise from 0 V to its ultimate stabilized level. After the internal Power-On Reset circuit detects that the V_{DD} has risen over the threshold voltage (V_{th}), it takes the time T_{POR} for the POR to change its state from logical 0 to 1. The V_{th} is about 1.2 V. The value of T_{POR} varies according to the time taken for the V_{DD} to rise from 0 to 3 V, as listed in Table 12. When the V_{DD} falls, the nRSTO follows with the V_{DD} simultaneously.

Table 12. T_{POR} Timing Characteristics

T_{RISE} (us)	T_{POR} (us)
3,000	500
1,000	300
300	160
100	100
30	70
10	60

5.11 The CLKO

A clock divided down from the crystal oscillator clock is output via the CLKO pin if the “System Clock Output” is set to “On” on the RFPDK. This clock can be used to drive the external MCU, and is available when the device is in the XTAL, TUNE and RX states. The clock frequency is selected by the option “System Clock Frequency”.

More details of using the CLKO can be referred to the “AN108 CMT2210A Configuration Guideline”.

6. Ordering Information

Table 13. CMT2210A Ordering Information

Part Number	Descriptions	Package Type	Package Option	Operating Condition	MOQ / Multiple
CMT2210A-EQR ^[1]	Low-Cost 300 – 480 MHz OOK Stand-Alone RF Receiver	QFN16 (3x3)	Tape & Reel	1.8 to 3.6 V, -40 to 85 °C	5,000
CMT2210A-EQR3 ^[1]	Low-Cost 315 MHz OOK Stand-Alone RF Receiver	QFN16 (3x3)	Tape & Reel	1.8 to 3.6 V, -40 to 85 °C	5,000
CMT2210A-EQR4 ^[1]	Low-Cost 433.92 MHz OOK Stand-Alone RF Receiver	QFN16 (3x3)	Tape & Reel	1.8 to 3.6 V, -40 to 85 °C	5,000

Note:

[1]. “E” stands for extended industrial product grade, which supports the temperature range from -40 to +85 °C.

“Q” stands for the package type of QFN16 (3x3).

“R” stands for the tape and reel package option, the minimum order quantity (MOQ) for this option is 5,000 pieces.

“3” in the suffix stands for in stock product of 315 MHz with no need of EEPROM programming.

“4” in the suffix stands for in stock product of 433.92 MHz with no need of EEPROM programming.

If the CMT2210A-EQR3/4 cannot meet the application requirements, the user can order the CMT2210A-EQR for self-customizing with the RFPDK.

Default Configurations	CMT2210A-EQR3	CMT2210A-EQR4	CMT2210A-EQR
Frequency	315.00 MHz	433.92 MHz	Random
Others	Refer to the default values in Table 10 of Page 13/14		

Visit www.hoperf.com to know more about the product and product line.

Contact sales@hoperf.com or your local sales representatives for more information.

7. Package Outline

The 16-pin QFN 3x3 illustrates the package details for the CMT2210A. Table 14 lists the values for the dimensions shown in the illustration.

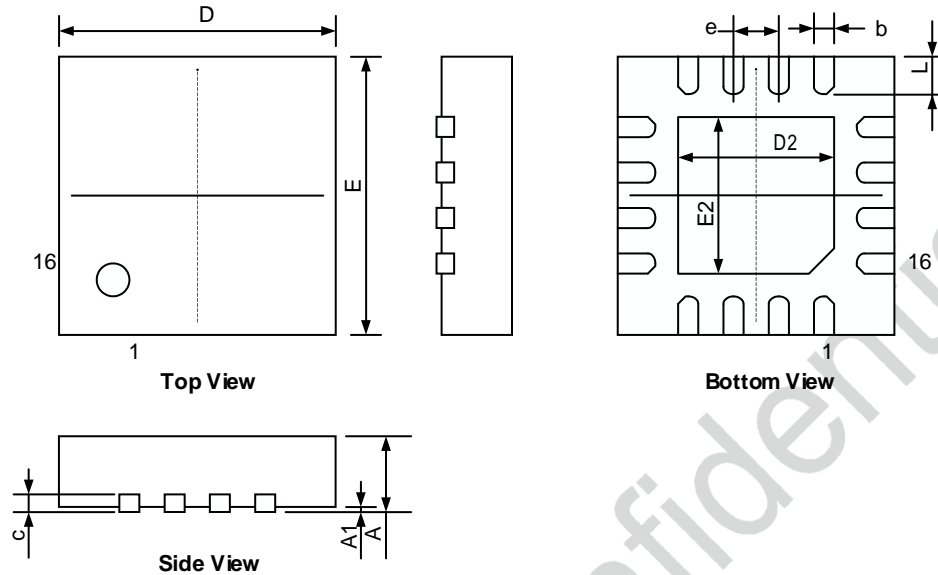

Figure 12. 16-Pin QFN 3x3 Package

Table 14. 16-Pin QFN 3x3 Package Dimensions

Symbol	Size (millimeters)	
	Min	Max
A	0.7	0.8
A1	—	0.05
b	0.18	0.30
c	0.18	0.25
D	2.90	3.10
D2	1.55	1.75
e	0.50 BSC	
E	2.90	3.10
E2	1.55	1.75
L	0.35	0.45

8. Top Marking

8.1 CMT2210A Top Marking

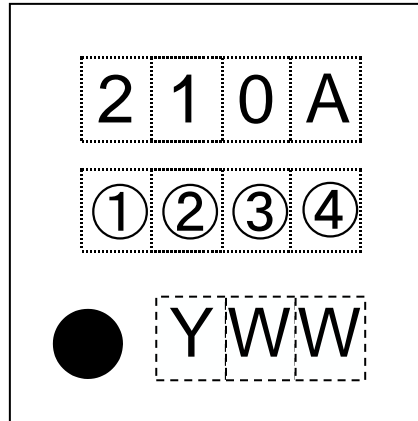

Figure 13. CMT2210A Top Marking

Table 15. CMT2210A Top Marking Explanation

Mark Method :	Laser
Pin 1 Mark :	Circle's diameter = 0.3 mm
Font Size :	0.5 mm, right-justified
Line 1 Marking :	210A, represents part number CMT2210A
Line 2 Marking :	①②③④ Internal tracking number
Line 3 Marking :	Date code assigned by the assembly house. Y represents the last digit of the mold year and WW represents the workweek

9. Other Documentations

Table 16. Other Documentations for CMT2210A

Brief	Name	Descriptions
AN103	CMT2110A/2210A One-Way RF Link Development Kits User's Guide	User's Guides for CMT2110A/2210A Development Kits, including Evaluation Board and Evaluation Module, CMOSTEK USB Programmer and RFPDK.
AN107	CMT2210A Schematic and PCB Layout Design Guideline	Details of CMT2210A PCB schematic and layout design rules, RF matching network and other application layout design related issues.
AN108	CMT2210A Configuration Guideline	Details of configuring CMT2210A features on the RFPDK.

10. Document Change List

Table 17. Document Change List

Rev. No	Chapter	Description of Changes	Date
0.9		Initial released version	2014-06-14
1.0	5	Update Section 5.7 and Figure 8	2014-06-30

CMR STEK Confidential

11. Contact Information

HOPE MICROELECTRONICS CO.,LTD

Add: 2/F, Building 3, Pingshan Private Enterprise Science and Technology Park, Lishan Road, XiLi Town, Nanshan District, Shenzhen, Guangdong, China

Tel: 86-755-82973805

Fax: 86-755-82973550

Email: sales@hoperf.com

Website: <http://www.hoperf.com>

<http://www.hoperf.cn>

HOPE MICROELECTRONICS CO.,LTD

Add: 2/F, Building 3, Pingshan Private Enterprise Science and Technology Park, Lishan Road, XiLi Town, Nanshan District, Shenzhen, Guangdong, China

Tel: 86-755-82973805

Fax: 86-755-82973550

Email: sales@hoperf.com

Website: <http://www.hoperf.com>

<http://www.hoperf.cn>

This document may contain preliminary information and is subject to change by Hope Microelectronics without notice. Hope Microelectronics assumes no responsibility or liability for any use of the information contained herein. Nothing in this document shall operate as an express or implied license or indemnity under the intellectual property rights of Hope Microelectronics or third parties. The products described in this document are not intended for use in implantation or other direct life support applications where malfunction may result in the direct physical harm or injury to persons. NO WARRANTIES OF ANY KIND, INCLUDING, BUT NOT LIMITED TO, THE IMPLIED WARRANTIES OF MERCHANTABILITY OR FITNESS FOR A PARTICULAR PURPOSE, ARE OFFERED IN THIS DOCUMENT.

©2006, HOPE MICROELECTRONICS CO.,LTD. All rights reserved.