

VOICE OTP IC

aP23682 – 682sec

aP23341 – 341sec

aP23170 – 170sec

aP23085 – 85sec

16 PIN

APLUS INTEGRATED CIRCUITS INC.

Address:

3 F-10, No. 32, Sec. 1, Chenggung Rd., Taipei,
Taiwan 115, R.O.C.
(115)台北市南港區成功路一段 32 號 3 樓之 10.

TEL: 886-2-2782-9266

FAX: 886-2-2782-9255

WEBSITE : <http://www.aplusinc.com.tw>

Sales E-mail:

sales@plusinc.com.tw

Support E-mail:

edit@plusinc.com.tw

▪ **FEATURES :**

- Standard CMOS process.
- Embedded 16M/8M/4M/2M EPROM.
- **682/341/170/85** sec Voice Length at 6KHz sampling and 4-bits ADPCM compression.
- Maximum 1024 voice groups.
- Maximum 48KHz sample rate.
- Combination of voice blocks to extend playback duration.
- User selectable PCM16 or ULAW8 or PCM8 or ADPCM4 data compression.
- 6 triggering modes are available :
 - Key Mode :
S1 ~ S4 to trigger up to 9 voice groups; Power on play function.
 - SBT Mode :
SBT to trigger up to 1024 voice groups sequentially; Power on play function.
 - CPU Parallel Mode :
S[4:1] services as 4-bits address to trigger up to 16 voice groups.
with SBT goes HIGH to strobe the address bits.
 - SPI Mode : CSB , SCK , DI.
3 wire address control up to 1024 voice groups.
 - I2C Mode : SCK , DI.
2 wire address control up to 1024 voice groups.
 - MP3 Mode :
S1:Backward , S2: Forward , S3:Stop , S4:Reset ,
SBT: (Play/Pause) or (Play/Stop) Trigger up to 1024 voice groups.
- Voice Group Trigger Options: Edge / Level; Hold / Unholdable; Retrigger / Non-retrigger.
- Optional 16ms or 65us selectable debounce time.
- RST pin set HIGH to stop the playback at once.
- LVD (Low voltage detect).
- Programmable outputs pin out1:
for busy-H , busy-L , stop-H , stop-L , prog busy-H , prog busy-L , Load,
LED flash (LED high active) , ~LED flash (LED low active).
- Three kind oscillator: Internal-Rosc 、 External-Rosc 、 Crystal.
- 2V – 5V single power supply and < 5uA low stand-by current.
- 16/8/4 level volume control setting available.
- 16 bits audio out.
- PWM Vout1 and Vout2 drive speaker directly.
- D/A COUT pin drives speaker through an external BJT or audio AMP.
- Development System support for voice compilation.

▪ **DESCRIPTION :**

aP23682/341/170/085 series high performance Voice OTP is fabricated with Standard CMOS process with embedded 16M/8M/4M/2M bits EPROM. It can store up to 682/341/170/85 sec voice message with 4-bits ADPCM compression at 6KHz sampling rate. 16-bits PCM 、 8-bits PCM and 8-bits ULAW at (4K to 48K sample rate) is also available for user selecting.

User selectable triggering and output signal options provide maximum flexibility to various applications. Built-in resistor controlled oscillator, 16-bits current mode DAC output and 14-bits PWM direct speaker driving output minimize the number of external components. PC controlled programmer and developing software are available.

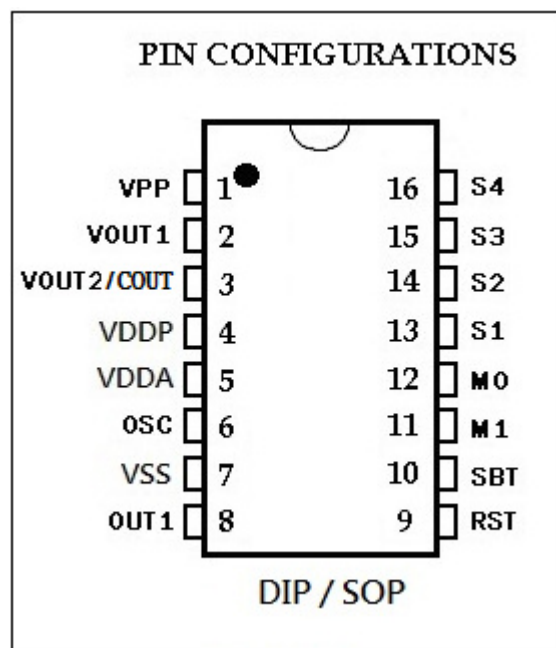

■ **PIN NAMES :**

PIN 16-pin	Playback Mode	OTP Program Mode	Description
1	VPP	VPP	Supply ground.
2	VOUT1		PWM output to drive speaker directly.
3	VOUT2/COUT		PWM output to drive speaker directly. / DAC current output.
4	VDDP	VDDP	Supply voltage.
5	VDDA	VDDA	Analog supply voltage.
6	OSC		Oscillator input.
7	VSS	VSS	Supply ground.
8	OUT1		Programmable output (I/O pin).
9	RST	RST	Reset pin (input pin with internal pull-down).
10	SBT	SBT	Trigger pin (I/O pin with internal pull-down).
11	M1		Mode select pin 1(input with internal pull-down).
12	M0		Mode select pin 0(input with internal pull-down).
13 ~ 16	S1~S4	S2、S3	Trigger pin (I/O pin with internal pull-down).

■ PIN DESCRIPTIONS :

S1 ~ S4 :

Input Trigger Pins:

- In Key Mode :S1 to S4 is used to trigger 9 voice groups.
 - In CPU Parallel Mode :This pin low to high [Latch] the address at S1(lsb) to S4(msb) and starts the voice playback.
 - In SPI Mode :
 - S1 is Chip Select (CSB) pin to initiate the command input.
 - S2 is the Serial Clock (SCK) pin which clocks the input command and data bits into the chip.
 - S3 is the Data In (DI) pin in which command and data bits are shifted input into the chip.
 - In I2C Mode :
 - S2 is the Serial Clock (SCK) pin which clocks the input command and data bits into the chip.
 - S3 is the Data In (DI) pin in which command and data bits are shifted input into the chip.
 - In MP3 Mode :
 - S1:Backward. S2 :Forward. S3:Stop. S4: Reset.
-

SBT :

Input Trigger Pin:

- In SBT Mode : This pin is trigger pin to play Voice Groups one time or looping sequentially up to 1024 Voice Groups.
 - In CPU Parallel Mode : This pin is used as address strobe to latch the Voice Group address input at S1 to S4 and starts the voice playback.
 - In MP3 Mode : This pin is (Play/Pause) or (Play/Stop).
-

VDDP and VDDA :

Power Supply Pins : These two pins must be connected to the positive power supply.

VSS :

Power Ground Pins : VSS and VPP pins must be connected together to the power ground during voice playback.

In Circuit Program : VSS and VPP pins must be separated to the power ground. Connect resistor between power ground and VPP.

VPP :

During voice playback, this pin and VSS must be connected together to the power ground.

In Circuit Program : This pin is connected to a separate 8.5V power supply voltage for OTP programming. Connect resistor between power ground and VPP.

Note : Resistor is 10K Ω .

M0 and M1 :

In Key Mode 、 SBT Mode 、 CPU Parallel Mode 、 MP3 Mode 、 SPI Mode 、 and I2C Mode , M0 and M1 can be used for Crystal oscillator or volume control.

VOUT1 and VOUT2 :

14-bits PWM output pins which can drive speaker and buzzer directly for voice playback.

COUT :

16-bits current mode DAC output for voice playback.

OSC :

During voice playback, an external resistor is connected between this pin and the VDD pin to set the sampling frequency. Or keep OSC floating if choosing INT-Rosc.

Note : External resistor is 68K Ω .

OUT1 :

OUT1 can select output function as below :

1. Busy- H : When voice is playing, output high level signal.
 2. Busy- L : Inverted output of Busy- H.
 3. LED- Flash : When voice is playing, output LED flash pulse.
 4. ~LED- Flash : Inverted output of LED- Flash.
 5. Stop- H : When voice plays finished, output stop pulse.
 6. Stop- L : Inverted output of Stop- H.
 7. Load : After load voice data to buffer success, output logic high signal.
 8. Prog-Busy - H : When voice of Prog-Busy set 1, high pulse output.
When voice of Prog-Busy set 0, low pulse output.
 9. Prog-Busy - L : Inverted output of Prog-Busy – H.
-

RST :

Chip reset in playback mode.

External reset pull high a capacitor if used internal reset not. capacitor :100nF

▪ **VOICE SECTION COMBINATIONS :**

Voice files created by the PC base developing system are stored in the built-in EPROM of the aP23682/341/170/085 chip as a number of fixed length Voice Blocks. Voice Blocks are then selected and grouped into Voice Groups for playback. Up to 1024 Voice Groups are allowed. A Voice Blocks Table is used to store the information of combinations of Voice Blocks and then group them together to form Voice Group.

Chip	aP23682	aP23341	aP23170	aP23085
Memory size	16M bits	8M bits	4M bits	2M bits
Max no. of Voice Block	2016	2016	2016	2016
Max. no. of Voice Group	1024	1024	1024	1024
Voice Length (@ 6KHz 4-bit ADPCM)	682 sec	341 sec	170 sec	85 sec

▪ **Example of Voice Block Combination :**

Assume here we have three voice files, they are “How are You?”, Sound Effect and Music. Each of the voice file is divided into a number of fixed length Voice Block and stored into the memory.

Voice block :

B1 = “How”	B2 = ”are”	B3 = ”You”
B4 = Sound Effect	B5 = Music1	B6 = Music2

Voice Blocks are grouped together using Voice Table to form Voice Group for playback:

Group no.	Voice Group contents	Voice Table Entries
Group 1	“How are You?”	B1+B2+B3
Group 2	Sound Effect + “How are You?”	B4+ B1+B2+B3
Group 3	“How are You?” + Music1	B1+B2+B3+B5
Group 4	Music2	B6

▪ **Voice Data Compression :**

Voice File data is stored in the on-chip EPROM as either 4-bits ADPCM or 8-bits PCM/ ULAW format or 16-bits PCM format. Voice data are stored as 16-bits PCM format is without compression. The voice playback quality is best. Voice data stored as 4-bits ADPCM or 8-bits PCM/ ULAW provide 4:2 data compression to save memory space. But voice playback quality will be lower than 16-bits PCM format.

▪ **Group Options :**

User selectable options that affect each individual group are called Group Options. They are:

- Edge or Level trigger.
- Unholdable or Holdable option.
- Re-triggerable or Non-retriggerable option.
- Stop pulse disable or enable.

Fig. 1 to Fig. 6 show the voice playback with different combination of triggering mode and the relationship between outputs and voice playback.

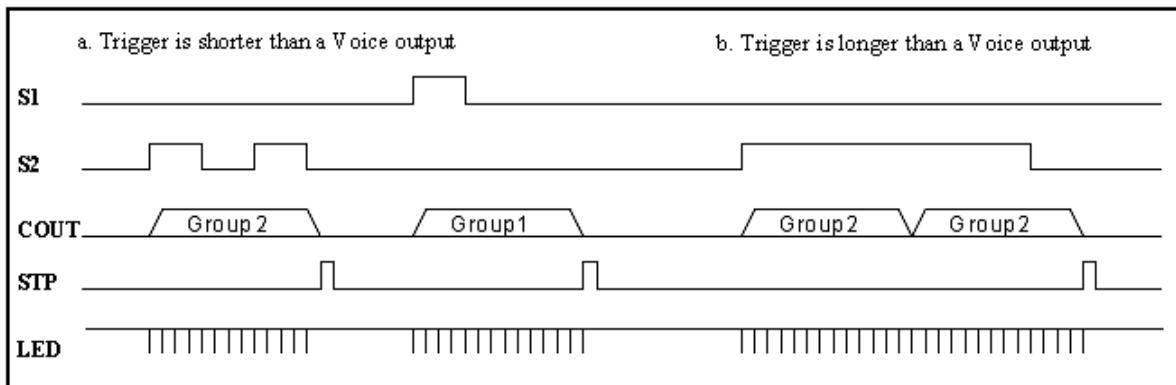

Fig. 1 Level, Unholdable, Non-retriggerable

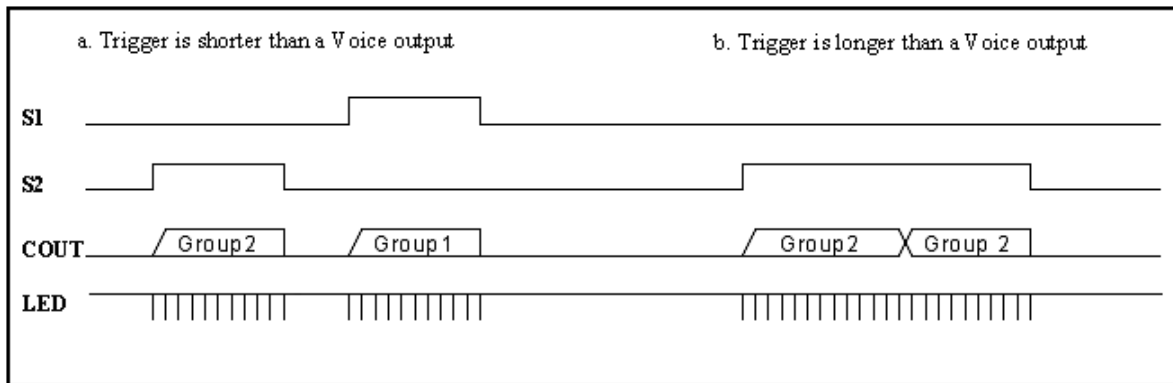

Fig. 2 Level Holdable

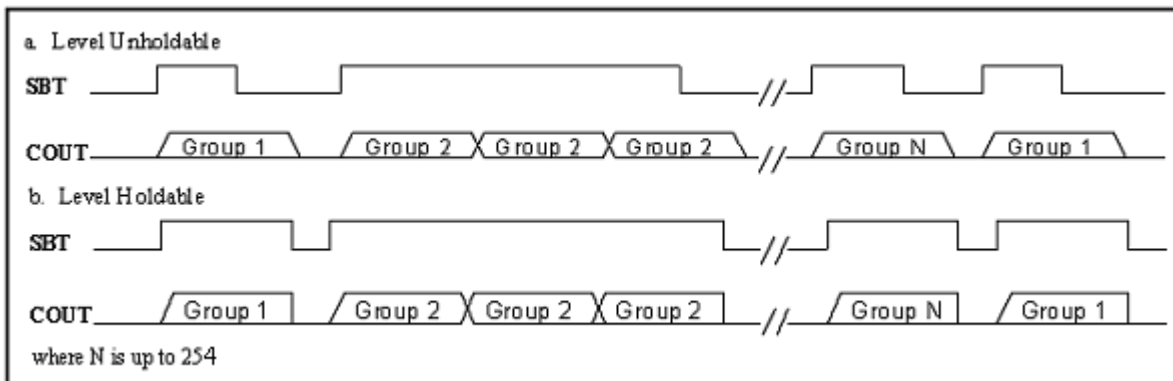

Fig. 3 SBT sequential trigger with Level Holdable and Unholdable

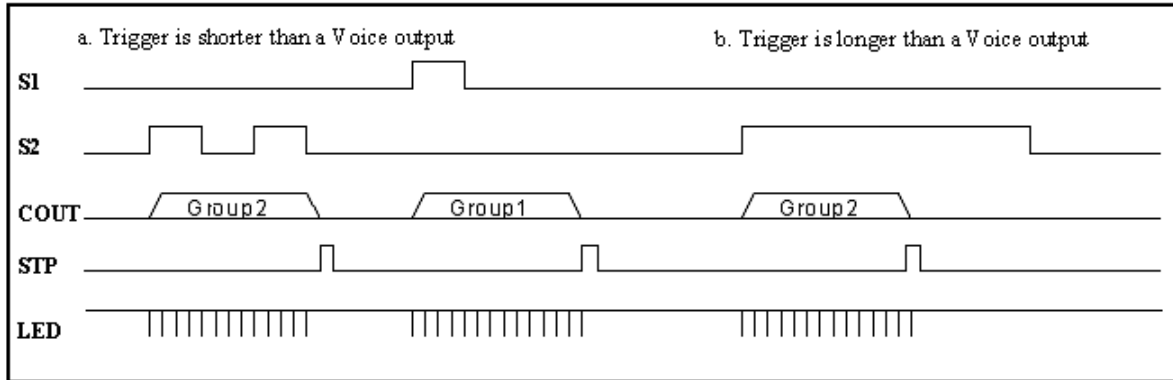

Fig. 4 Edge, Unholdable, Non-retrigger

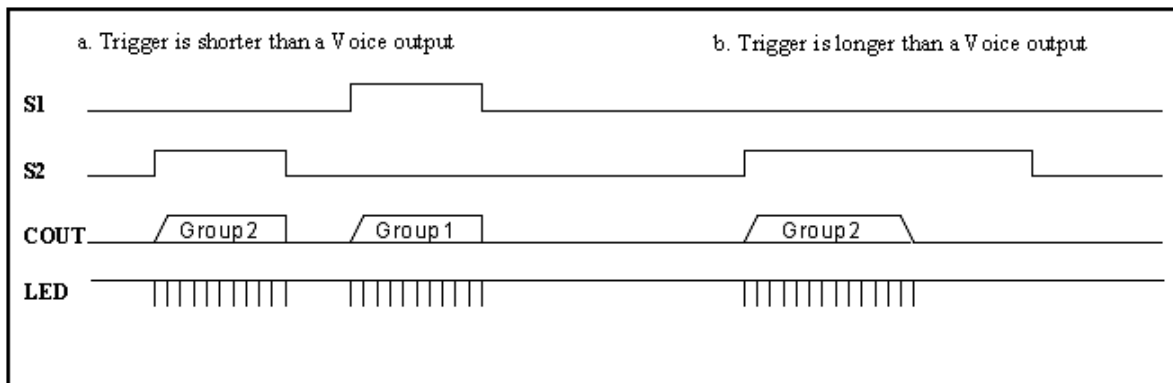

Fig. 5 Edge, Holdable

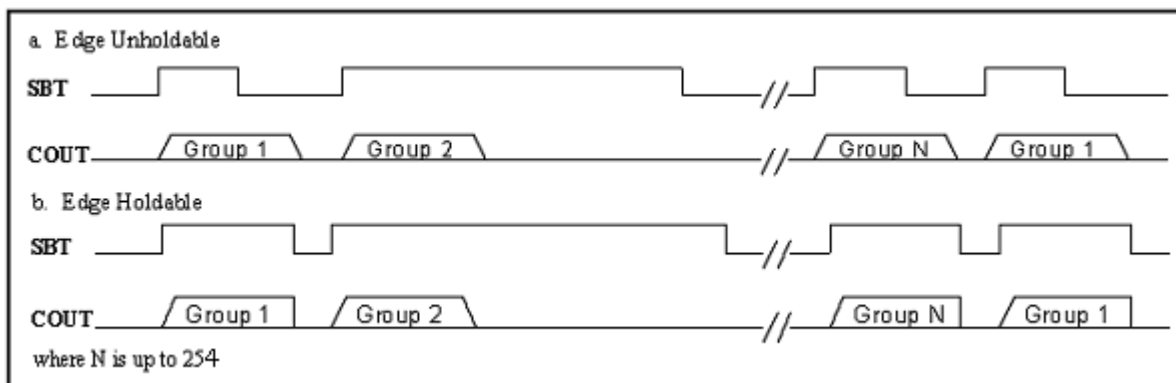

Fig. 6 SBT sequential trigger with Edge Holdable and Unholdable

▪ **TRIGGER MODES :**

There are six trigger modes available for aP23682/341/170/085 series.

- Key Mode.
- SBT Mode.
- CPU Parallel Mode.
- SPI Mode.
- I2C Mode.
- MP3 Mode.

• **Key Mode :**

With this trigger mode, the beginning 9 Voice Groups are triggered by setting S1 to S4 to HIGH or LOW in different combinations. Each Voice Group can have its only independent trigger options (See Fig. 1,2,4 and 5 for trigger options definition).

The setting of S1 to S4 for triggering the 1st to the 9nd Voice Groups are as follow:

Voice Group	S1	S2	S3	S4
SW1	HIGH	NC	NC	NC
SW2	NC	HIGH	NC	NC
SW3	NC	NC	HIGH	NC
SW4	NC	NC	NC	HIGH
SW5	HIGH	HIGH	NC	NC
SW6	NC	HIGH	HIGH	NC
SW7	NC	NC	HIGH	HIGH
SW8	HIGH	HIGH	HIGH	NC
SW9	HIGH	HIGH	HIGH	HIGH

★★★ Note: NC represents open or no connection

• **SBT Mode :**

A maximum of 1024 Voice Groups are available. And can be triggered one by one sequentially with the SBT key (See Fig. 3 and 6).

- CPU Parallel Mode :**

In this mode, S4 to S1 serve as 4-bits addresses input for 16 Voice Groups with S4 represents the MSB and S1 represents LSB. After Group address is set and ready, setting the SBT input pin LOW to HIGH will [LATCH] and trigger the corresponding Voice Group to playback.

Trigger options defined in Fig. 1,2, 4 and 5 are valid for this mode.

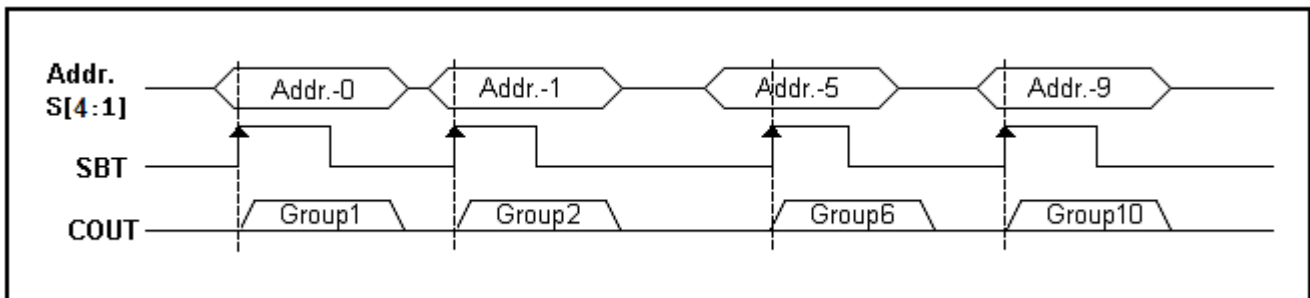

Fig. 7 CPU Parallel Trigger Mode

Note that SBT pin cannot be used as Single Button Sequential trigger in this mode(Fig. 7). For instead, it acts as a Strobe input to clock-in the Voice Group address set at S1 to S4 into the chip.

Voice Groups are represented in Binary address format. For example:

- [S4:S1] = 0000 0000 (00hex) for Voice Group #1
- [S4:S1] = 0000 0001 (01hex) for Voice Group #2
-
- [S4:S1] = 0000 1000 (08 hex) for Voice Group #9
-
- [S4:S1] = 0000 1111 (0F hex) for Voice Group #16

CPU Serial Command Description :

CPU Serial Command include **SPI Mode** 、 **I2C Mode**.

The command support to reference Fig.8 CPU Serial Command Description.

LOAD	<ol style="list-style-type: none"> 1. This command pre-load the next Voice Group Address into the address buffer. 2. The "Full/Load" signal will become HIGH once the Group Address is loaded. 3. The Voice Group will be played once the playing of the current Voice Group is finished. 4. The "Full/Load" signal will become LOW once the Voice Group is played and the address buffer is released and ready for next PREFECT action. 5. Using this command make sure there is no gap between each Voice Group.
PLAY	<ol style="list-style-type: none"> 1. This command load the Voice Group Address into the address buffer. 2. The current Voice Group will be stopped and play the new one.
PU1	Power up the chip without ramp-up (suitable for PWM direct drive).
PU2	Power up the chip with ramp-up (suitable for COUT transistor drive).
PD1	Power down the chip without ramp-down (suitable for PWM direct drive).
PD2	Power down the chip with ramp-down (suitable for COUT transistor drive).
VOL	Set Volume index of volume Table.
VOL--	Decrease the volume index of volume Table.
VOL++	Increase the volume index of volume Table.
PAUSE	Pause the current Voice Group.
RESUME	Resume the current Voice Group.
STOUT	Device Status Output.

Fig. 8 CPU Serial Command Description

***Note:** If not selecting volume control function in CPU serial control, its default value would be fixed at "16 level". (In Compiler software: 23KW-Software-V2.5).

State Description :

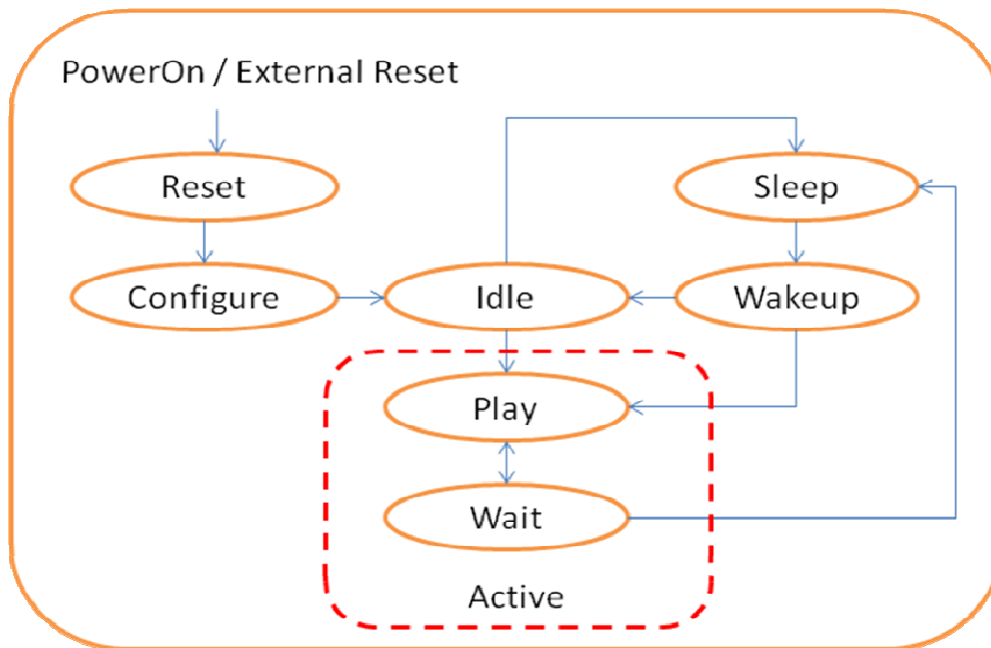

State Name	Description
Reset	Include Power On Reset (typ 5us) and external reset (depends on the external reset circuit). All pins are input floating. Serial Command inhibited. After reset, state transfer to the "Configure" state.
Configure	Internal Chip Configuration. All pins are input floating. Serial Command inhibited. (Max configure time = 2ms) After configuration, state transfer to the "Idle" state.
Idle	State transfer to the " Play " state if " active command " received before timeout. After time out without active command, state transition to the " Sleep " State.
Play	Playing Voice Group include ramp. State transfer to the "Wait" state if nothing to be played.
Wait	Wait new Serial command and back to the play state without time limit. State transition to the " Sleep " state if " de-active command " received. Ramp down before transition to the sleep if the "PD2" command be accepted.
Sleep	State transition to the "Wakeup" state if selected by the host CPU. (Wait sleep to wakeup state time = 20us.)
Wake up	Single command be buffered and wait to execute after wakeup state!! (Max wakeup time = 2ms). State transition to the "Play" state if active command received else to the "Idle" state.

Fig. 9 State Description

*** Active commands are "Load", "Play", "PU1" and "PU2".
De-Active commands are "PD1" and "PD2".

In CPU Serial Command Control :

- Using PU1/PU2 command first from de-active state.
Add 2ms delay after PU1/PU2 command is necessary.
- Max "Output Delay of Busy/Full Signal" equal 2ms during active.
- Output select to reference PIN DESCRIPTIONS of OUT1.

• **SPI Mode :**

This trigger mode is specially designed for simple CPU interface. The aP23682/341/170/085 is controlled by command sent to it from the host CPU. S1 to S3 are used to input command word into the chip while OUT1 as output from the chip to the host CPU for feedback response.

- S1 acts as CSB (Chip Select) to initiate the command word input.
- S2 acts as SCK (Serial Clock) to clock-in the command word at rising edge.
- S3 acts as DI (Data-In) to input the command bits.
- OUT1 acts as BUSY to indicate the chip is in busy state(include play and ramp).
- M0 acts as volume level increase.
- M1 acts as volume level decrease.

SPI Command Table [MSB First] : Command input into the chip 16-bits data.

Command	D15	D14	D13	D12	D11	D10	D[9:0]						
LOAD	1	0	0	1	0	1	Voice Group Address Number.						
PLAY	1	0	0	1	1	0	Voice Group Address Number.						
PU1 w/o Ramp	1	0	1	0	0	1	don't care.						
PU2 with Ramp	1	0	1	0	1	0	don't care.						
PD1 w/o Ramp	1	0	1	1	0	1	don't care.						
PD2 with Ramp	1	0	1	1	1	0	don't care.						
VOL	0	1	0	0	0	1	0	0	0	0	0	0	VOL[3:0]
VOL++	0	1	0	0	1	0	don't care.						
VOL--	0	1	0	1	0	1	don't care.						
PAUSE	0	1	1	0	0	1	don't care.						
RESUME	0	1	1	0	1	0	don't care.						

Fig. 10 SPI Command Table

SPI Command Timing Diagram:

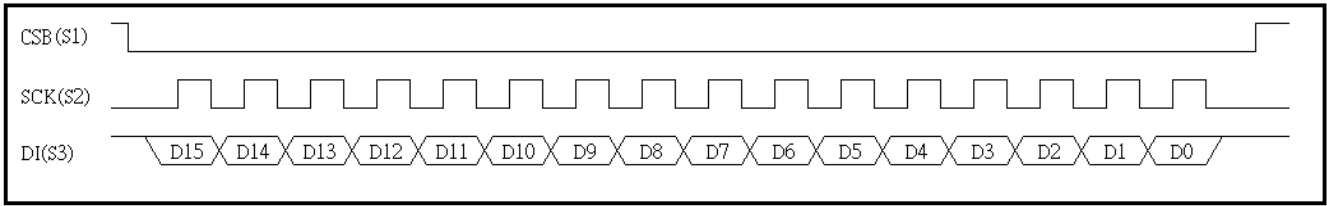

Fig.11 SPI Command timing

* Data is latched at rising edge of SCK.

* SPI Command function reference Fig. 8 CPU Serial Command Description.

Power up with RAMP-UP(PU2) or without RAMP-UP(PU1)

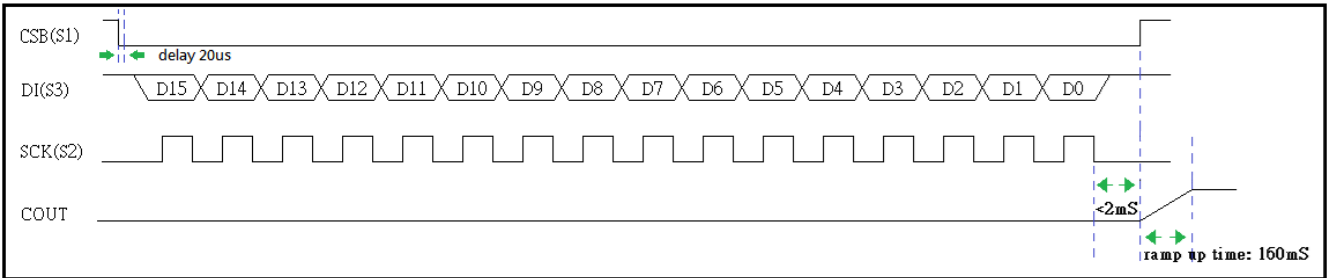

Fig. 12 Power-Up command timing

* Ramp up time : 160mS

Power down with RAMP-DOWN(PD2) or without RAMP-DOWN (PD1)

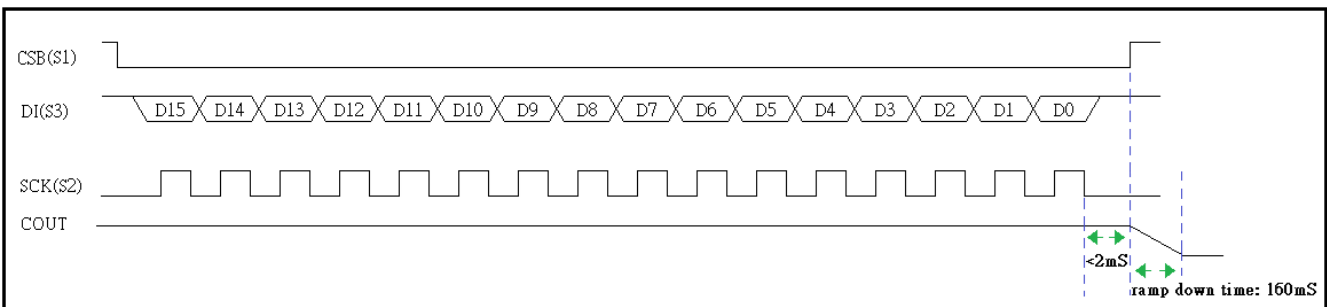

Fig. 13 Power-Down command timing

* Ramp down time : 160mS

- (1). Load Voice Group Address :
 - a. Command timing reference Fig.11 SPI Command timing.
 - b. D9 to D0 total 10 bits to be the Group Address.
 - c. The OUT1 output (Load) will become logic high once the Group Address is successfully loaded.
 - d. The Load signal will become logic LOW once the Voice Group is played and the address buffer is released and ready for next Play action.

- (2). Play Voice Group Address :
 - a. Command timing reference Fig.11 SPI Command timing.
 - b. D9 to D0 total 10 bits to be the Group Address.
 - c. Playing assign group address immediately.

- (3). Power up with RAMP-UP(PU2) or without RAMP-UP(PU1) :
 - a. Command timing reference Fig. 12 Power-Up command timing.
 - b. PU1 : will power-up the chip and set the VOUT to center value immediately and stay there.
 - c. PU2 : will power-up the chip and ramp-up COUT from bottom to center value and stay there.

- (4). Power-down with RAMP-DOWN(PD2) or without RAMP-DOWN (PD1) :
 - a. Command timing reference Fig. 13 Power-Down command timing.
 - b. PDN1 will power-down the chip and set the VOUT data to bottom value immediately.
PDN1 will be executed correctly only if PU1 is executed before.
 - c. PDN2 will power-down the chip and ramp-down the COUT from its current to bottom value.
PDN2 will be executed correctly only if PU2 is executed before.

- (5). Volume Set (VOL[3:0]) :
 - a. Command timing reference Fig.11 SPI Command timing.
 - b. D3 to D0 total 4bits(0 ~ 15) set volume level (max : 0, min : 15), if volume level is 16.
 - c. D2 to D0 total 3bits(0 ~ 7) set volume level (max : 0, min : 7), if volume level is 8.
 - d. D1 to D0 total 2bits(0 ~ 3) set volume level (max : 0, min : 3), if volume level is 4.

- (6). Volume ++ (VOL++) :
 - a. Command timing reference Fig.11 SPI Command timing.
 - b. Set volume level increase.

- (7). Volume -- (VOL--) :
 - a. Command timing reference Fig.11 SPI Command timing.
 - b. Set volume level decrease.

- (8). Pause and Resume (PAUSE; RESUME) :
 - a. Command timing reference Fig.11 SPI Command timing.
 - b. In Pause state, VOUT1 and VOUT2 will stay at logic LOW while the COUT will stay at the current D/A data level. When Resume, the COUT data will continue at the current D/A data level.

• **I2C Mode :**

This trigger mode is specially designed for simple CPU interface. The aP23682/341/170/085 is controlled by command sent to it from the host CPU. S2 and S3 are used to input command word into the chip while OUT1 as output from the chip to the host CPU for feedback response.

- S2 acts as SCK (Serial Clock) to clock-in the command word at rising edge.
- S3 acts as DI (Data-In) to input the command bits.
- OUT1 acts as BUSY to indicate the chip is in busy state(include play and ramp).
- M0 acts as volume level increase.
- M1 acts as volume level decrease.

P.S.:

This mode named "I2C mode" in the document/software, but it's NOT compatible with standard I2C device(e.g. NOT implemented ACK, and no device/register address supported).

I2C Command Table [MSB First] : Command input into the chip 16-bits data.

Command	D15	D14	D13	D12	D11	D10	D[9:0]						
LOAD	1	0	0	1	0	1	Voice Group Address Number.						
PLAY	1	0	0	1	1	0	Voice Group Address Number.						
PU1 w/o Ramp	1	0	1	0	0	1	don't care.						
PU2 with Ramp	1	0	1	0	1	0	don't care.						
PD1 w/o Ramp	1	0	1	1	0	1	don't care.						
PD2 with Ramp	1	0	1	1	1	0	don't care.						
VOL	0	1	0	0	0	1	0	0	0	0	0	0	VOL[3:0]
VOL++	0	1	0	0	1	0	don't care.						
VOL--	0	1	0	1	0	1	don't care.						
PAUSE	0	1	1	0	0	1	don't care.						
RESUME	0	1	1	0	1	0	don't care.						

Fig. 14 I2C Command Table

I2C Command Timing Diagram:

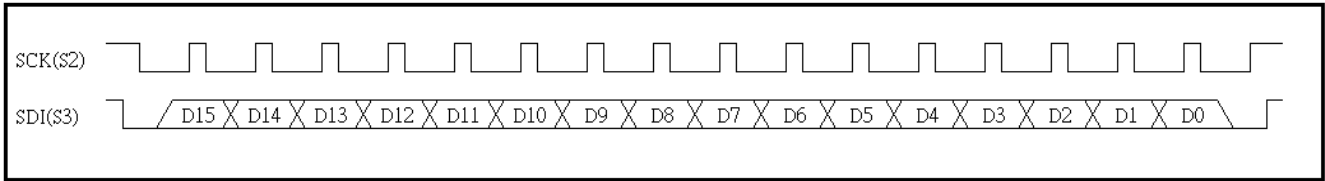

Fig.15 I2C Command timing

* The data bit only can be changed in SCK low level , but it has to be latched before rising edge of SCK.

* I2C Command function reference Fig. 8 CPU Serial Command Description.

Power up with RAMP-UP(PU2) or without RAMP-UP(PU1)

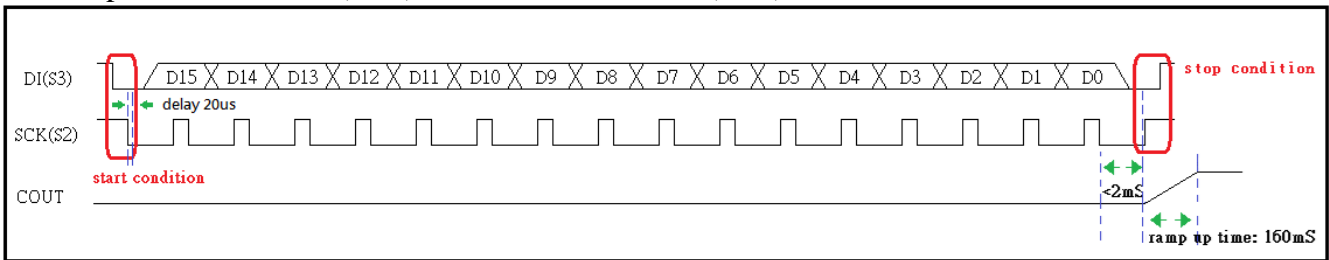

Fig. 16 Power-Up command timing

* Ramp up time : 160mS

Add stop condition after power on and internal chip configuration time finish.

In Power up command : After start condition signal, add delay time more than 300us to wake up device.

Power-down with RAMP-DOWN(PD2) or without RAMP-DOWN (PD1)

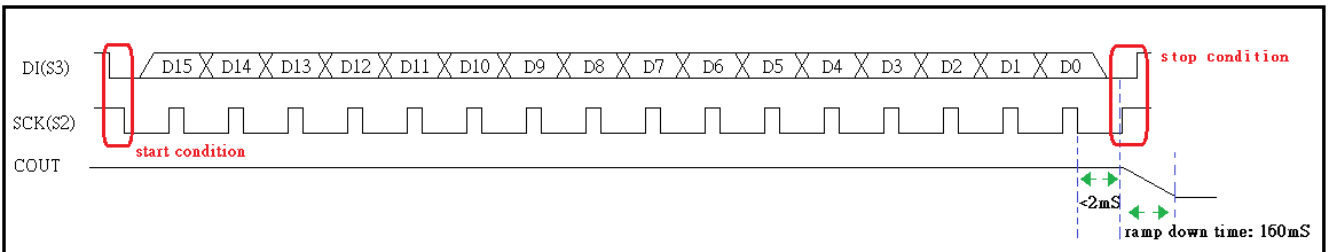

Fig. 17 Power-Down command timing

* Ramp down time : 160mS

- (1). Load Voice Group Address :
 - a. Command timing reference Fig.15 I2C Command timing.
 - b. D9 to D0 total 10 bits to be the Group Address.
 - c. The OUT1 output (Load) will become logic high once the Group Address is successfully loaded.
 - d. The Load signal will become logic LOW once the Voice Group is played and the address buffer is released and ready for next Play action.

- (2). Play Voice Group Address :
 - a. Command timing reference Fig.15 I2C Command timing.
 - b. D9 to D0 total 10 bits to be the Group Address.
 - c. Playing assign group address immediately.

- (3). Power up with RAMP-UP(PU2) or without RAMP-UP(PU1) :
 - a. Command timing reference Fig. 16 Power-Up command timing.
 - b. PU1 : will power-up the chip and set the VOUT to center value immediately and stay there.
 - c. PU2 : will power-up the chip and ramp-up COUT from bottom to center value and stay there.

- (4). Power-down with RAMP-DOWN(PD2) or without RAMP-DOWN (PD1) :
 - a. Command timing reference Fig. 17 Power-Down command timing.
 - b. PDN1 will power-down the chip and set the VOUT data to bottom value immediately.
PDN1 will be executed correctly only if PU1 is executed before.
 - c. PDN2 will power-down the chip and ramp-down the COUT from its current to bottom value.
PDN2 will be executed correctly only if PU2 is executed before.

- (5). Volume Set (VOL[3:0]) :
 - a. Command timing reference Fig.15 I2C Command timing.
 - b. D3 to D0 total 4bits(0 ~ 15) set volume level (max : 0, min : 15), if volume level is 16.
 - c. D2 to D0 total 3bits(0 ~ 7) set volume level (max : 0, min : 7), if volume level is 8.
 - d. D1 to D0 total 2bits(0 ~ 3) set volume level (max : 0, min : 3), if volume level is 4.

- (6). Volume ++ (VOL++) :
 - a. Command timing reference Fig.15 I2C Command timing.
 - b. Set volume level increase.

- (7). Volume -- (VOL--) :
 - a. Command timing reference Fig.15 I2C Command timing.
 - b. Set volume level decrease.

- (8). Pause and Resume (PAUSE; RESUME) :
 - a. Command timing reference Fig.15 I2C Command timing.
 - b. In Pause state, VOUT1 and VOUT2 will stay at logic LOW while the COUT will stay at the current D/A data level. When Resume, the COUT data will continue at the current D/A data level.

- **MP3 Mode :**

This trigger mode is specially designed for simple MP3 function.

User can start to Play or Pause the voice by SBT pin, and Backward or Forward play by S1 pin or S2 pin, up to 1024 Voice Sections.

- SBT acts as (play/pause) or (play/stop).
- S1 acts as backward.
- S2 act as forward.
- S3 acts as stop.
- S4 act as reset.
- M0 acts as volume level increase.
- M1 acts as volume level decrease.

Option :

SPI Mode and I2C Mode are Pin S4 as data output (DO)using.
DO (Pin S4) as output from the chip to the host CPU for feedback response.

DO(Pin S4) Output the status bits :

Status	Description
S [15:9]	Reserved.
S [8]	STO_TAG.
S [7]	STO_BUSYB.
S [6]	STO_FULLB / STO_EMPTY.
S [5]	Reserved.
S [4]	Reserved.
S [3]	Reserved.
S [2]	STO_VALIDB.
S [1]	STO_PARITY.
S [0]	STO_TAG.

Fig. 18 Output Status Table

S [15:9] : Reserved.

S [8] : STO_TAG : When received valid command the bit toggle.

S [7] : STO_BUSYB : When voice is playing the bit indicate 0 otherwise 1.

S [6] : STO_FULLB/STO_EMPTY : If voice group is waiting to be played ,the bit indicate 0 otherwise 1.

S [5:3] : Reserved.

S [2] : STO_VALIDB : If the last serial command is valid the bit indicate 0 otherwise 1.

S [1] : STO_PARITY : If digit 1 in group address[D9~D0] total are odd numbers, the bit indicate 0 otherwise 1.

S [0] : STO_TAG : When received valid command the bit toggle.

SPI Mode :

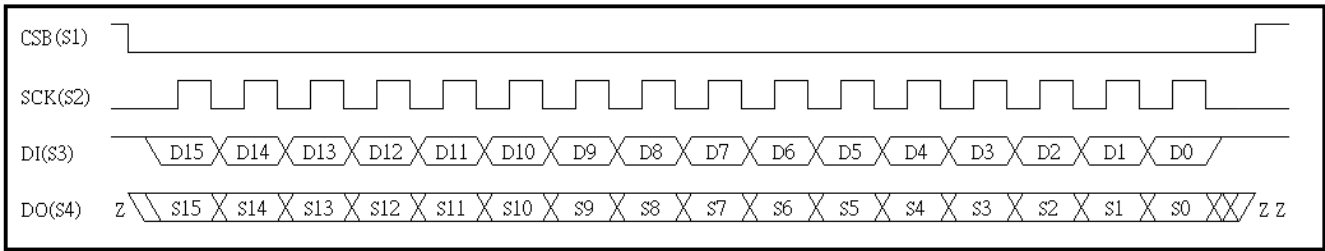

Fig. 19 SPI Data Output Command timing

* Data output to be changed at falling edge of SCK.

SPI TIMING WAVEFORMS

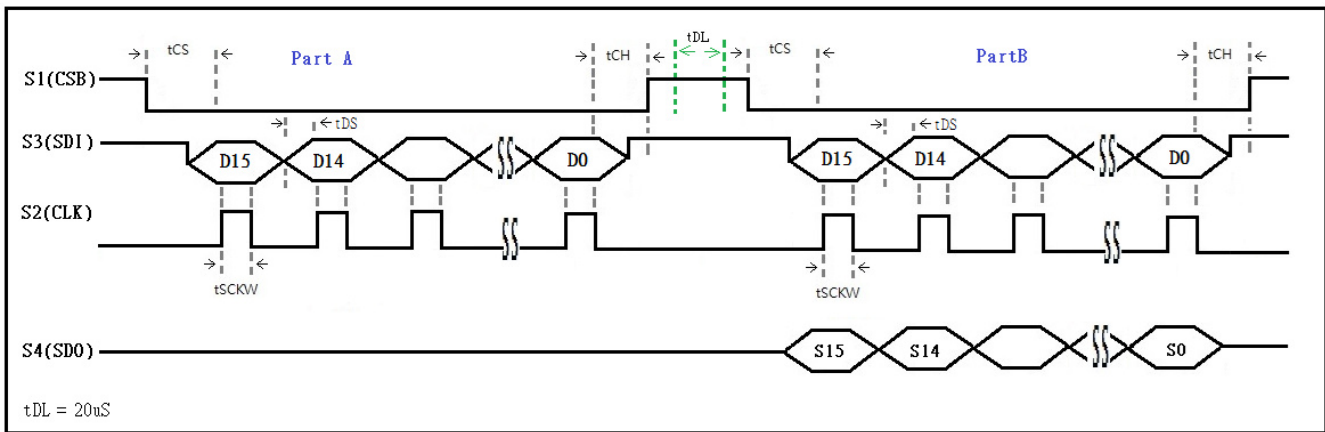

Fig. 20

Part A : Using command reference Fig. 10 SPI Command Table.

Part B : Using command is STOUT.

STOUT Command [MSB First] : Command input into the chip 16-bits data.

Command	D15	D14	D13	D12	D11	D10	D[9:0]
STOUT	0	1	1	1	1	0	don't care.

(1). STOUT(Status Out) :

- a. Command timing reference Fig. 19 SPI Data Output Command timing.
- b. Get Device Status.

I2C Mode :

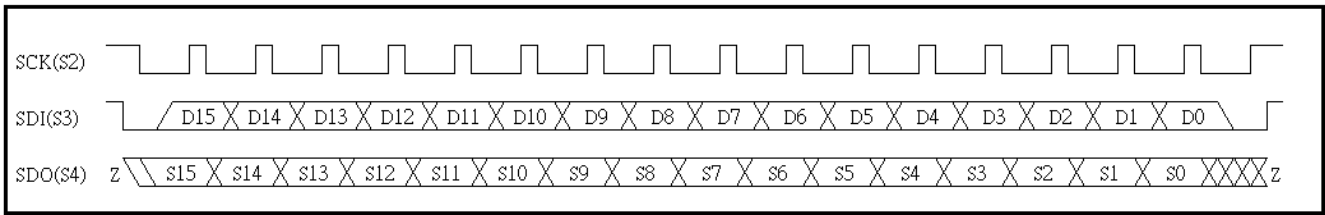

Fig. 21 I2C Data Output Command timing

* Data output to be changed at falling edge of SCK.

I2C TIMING WAVEFORMS

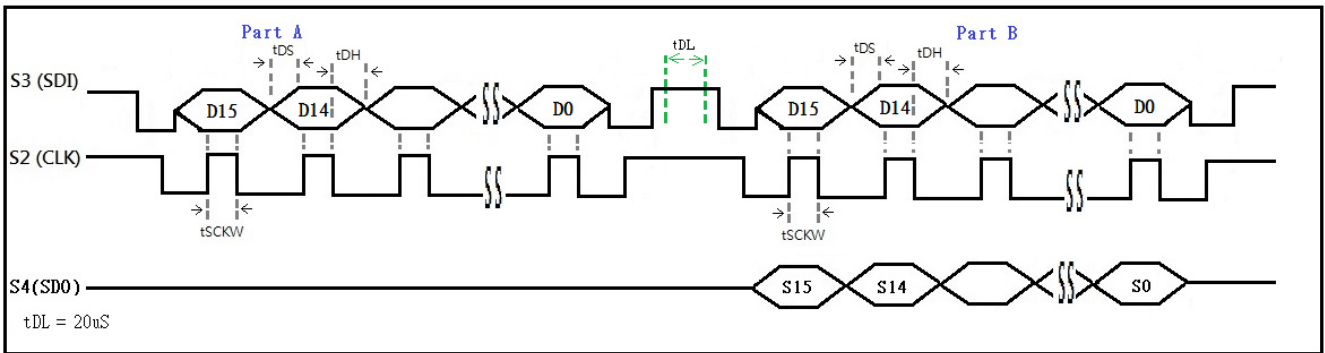

Fig. 22

Part A : Using command reference Fig. 14 I2C Command Table.

Part B : Using command is STOUT.

STOUT Command [MSB First] : Command input into the chip 16-bits data.

Command	D15	D14	D13	D12	D11	D10	D[9:0]
STOUT	1	1	1	1	1	1	don't care.

(1). STOUT(Status Out) :

- a. Command timing reference Fig. 21 I2C Data Output Command timing.
- b. Get Device Status.

▪ **Oscillator Resistance :**

We have 3 modes can choose: Internal resistor 、 External resistor 、 Crystal resistance.

Rosc Int – No need to add resistor for OSC.

Rosc Ext – Use 68K ohm resistor in OSC pin.

XT - Setting Crystal mode in M0 pin and M1 pin.

1. The crystal use 16MHz.
2. Use C1 , C2 for capacitor depend on Crystal spec.

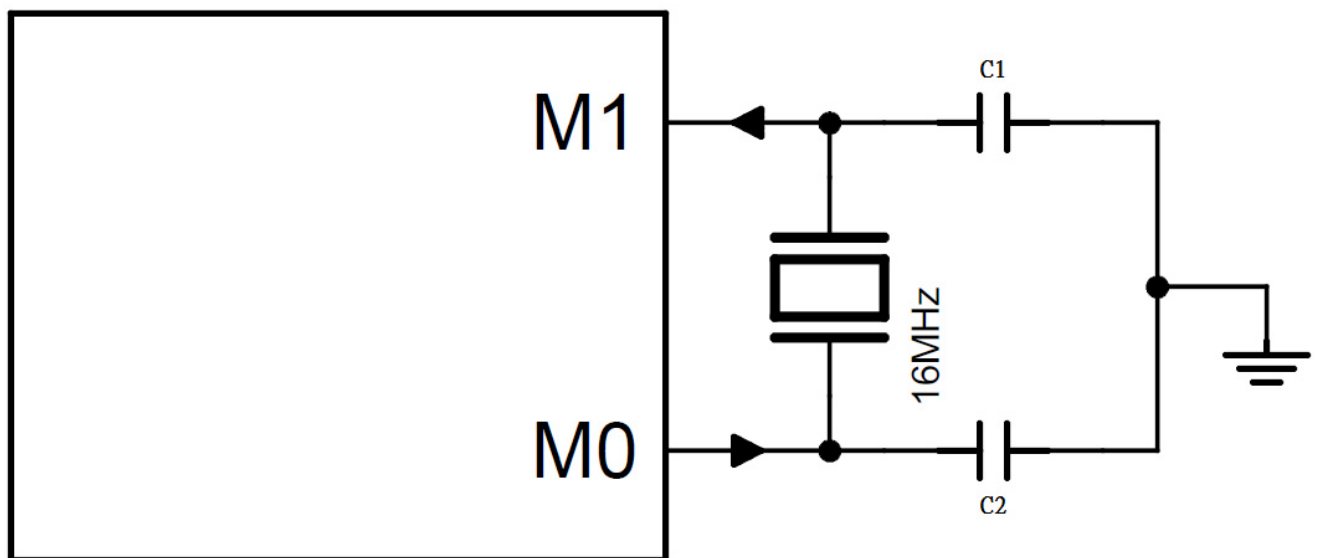

▪ **Reset Circuit for Hot Plug-in Applications :**

LVD provide basic voltage monitoring and prevent chip malfunction at low supply voltage which is around 1.3v to 2.0v. The supply voltage may be lower than 1.3v in hot plug-in applications. We recommend adding a resistor as an external low voltage reset circuit to promote system stability in hot plug-in applications. The drawing shown below is the external low voltage reset circuit.

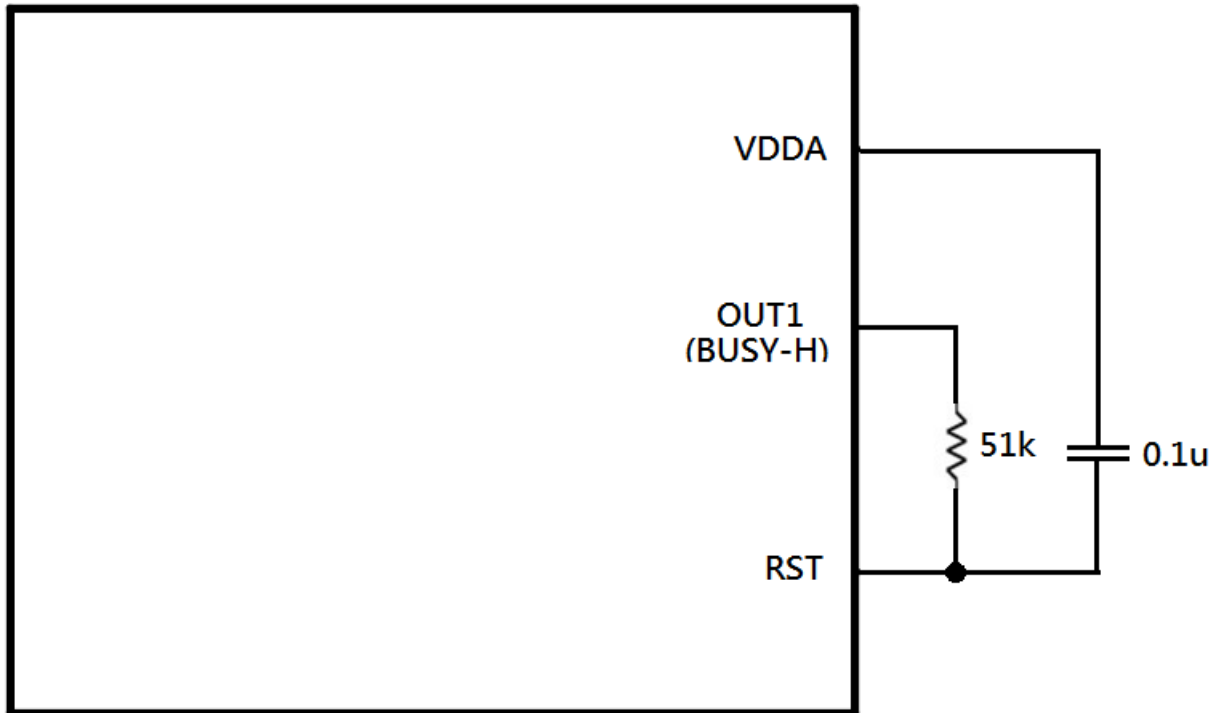

If there is no more OUT pin to act as busy-h, you can add a resistor between VDDA and RST to implement the external low voltage reset circuit. But there is dc current which is about 100uA.

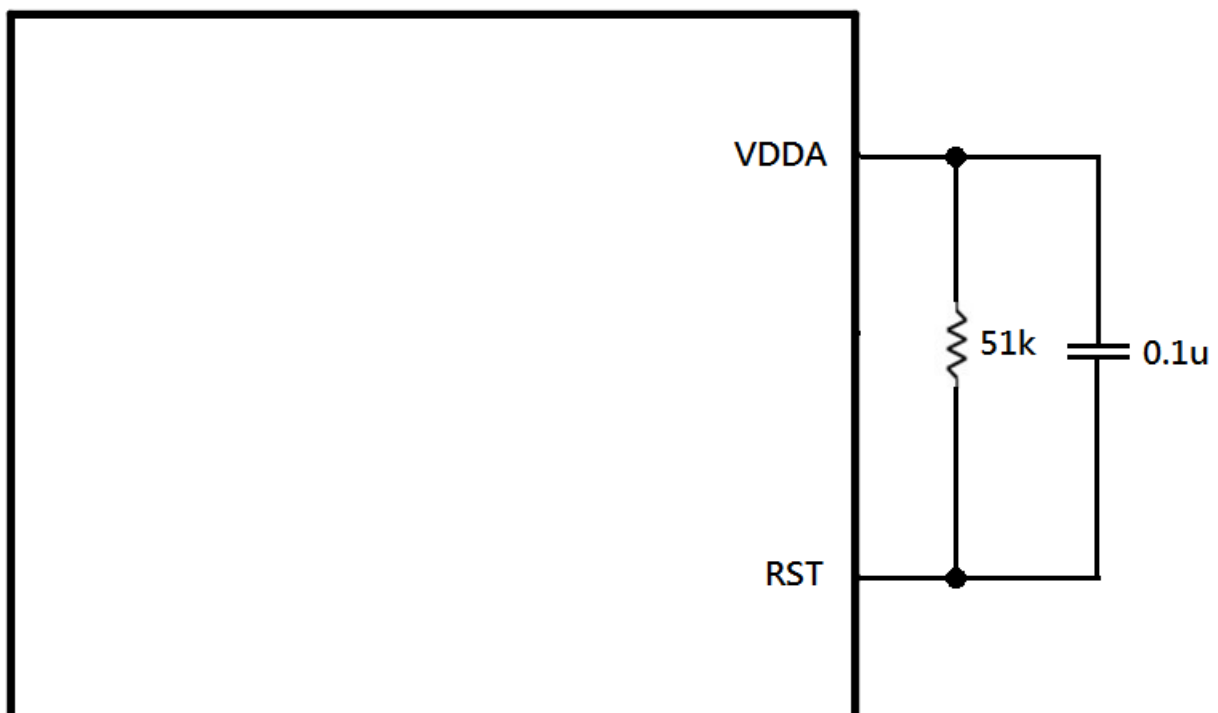

▪ **BLOCK DIAGRAM :**

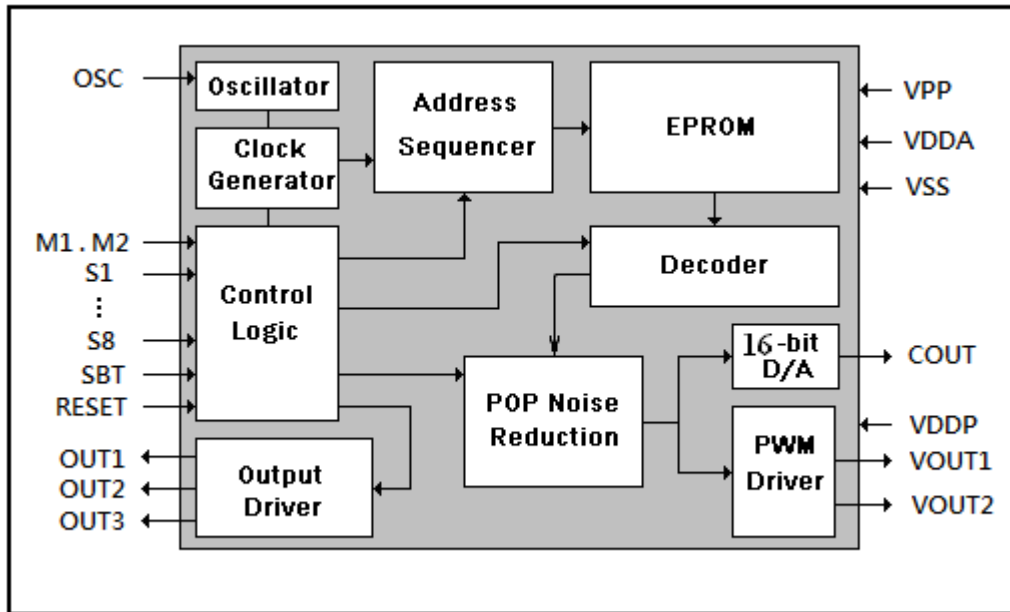

Fig. 23 Block Diagram

▪ **ABSOLUTE MAXIMUM RATINGS :**

Symbol	Rating	Unit
$V_{DD} - V_{SS}$	-0.5 ~ +5.0	V
V_{IN}	$V_{SS} - 0.3 < V_{IN} < V_{DD} + 0.3$	V
V_{OUT}	$V_{SS} < V_{OUT} < V_{DD}$	V
T (Operating):	-10 ~ +85	°C
T (Junction)	-10 ~ +85	°C
T (Storage)	-10 ~ +85	°C

DC CHARACTERISTICS ($T_A = 0$ to 70°C)

Symbol	Parameter	Min.	Typ.	Max.	Unit	Condition
VDD	Operating Voltage	2.0		5.0	V	
$\Delta F_c/F_c$	Chip to chip frequency variation	-1.5		+1.5	%	

Symbol	Parameter	VDD	Min.	Typ.	Max.	Unit	Condition
I _{SB}	Standby current	3.3			1.0	uA	
		4.5			1.0		
I _{OP}	Operating current	3.3		11		mA	
		4.5		18			
I _{IH}	Input current	3.3		7		uA	V _{IL} =3.3V
		4.5		17			V _{IL} =4.5V
V _{IH}	Input high voltage	3.3		2/3 VDD		V	
		4.5					
V _{IL}	Input low voltage	3.3		1/3 VDD		V	
		4.5					
I _{OH}	Output high current	3.3		-16		mA	V _{OH} =2.0V
		4.5		-25			V _{OH} =3.5V
I _{OL}	Output low current	3.3		26		mA	V _{OL} =1.0V
		4.5		36			
I _{VOUT}	VOUT Current	3.3		150		mA	Load=8Ω
		4.5		220			
I _{COUT}	COUT Current	3.3		4		mA	V _{COUT} =1.0V full scale
		4.5		4			
$\Delta F/F$	Frequency Stability	3.3		1.5		%	Note1
		4.5		1.5			Note2

Note1:

$$\frac{F_{osc}(3.3) - F_{osc}(2.7)}{F_{osc}(3.3)}$$

Note2:

$$\frac{F_{osc}(5.0) - F_{osc}(4.5)}{F_{osc}(4.5)}$$

▪ **TIMING WAVEFORMS :**

- KEY 、 SBT and MP3 Trigger Mode :

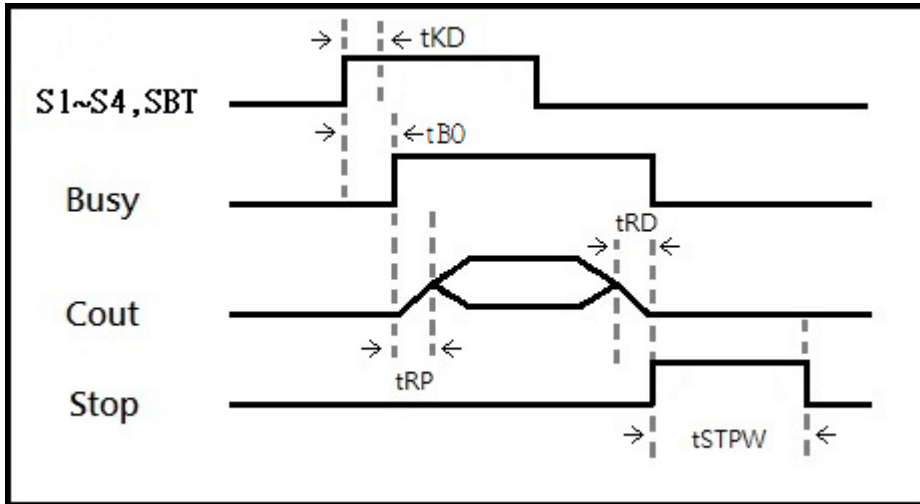

Fig. 24

- CPU Parallel Mode :

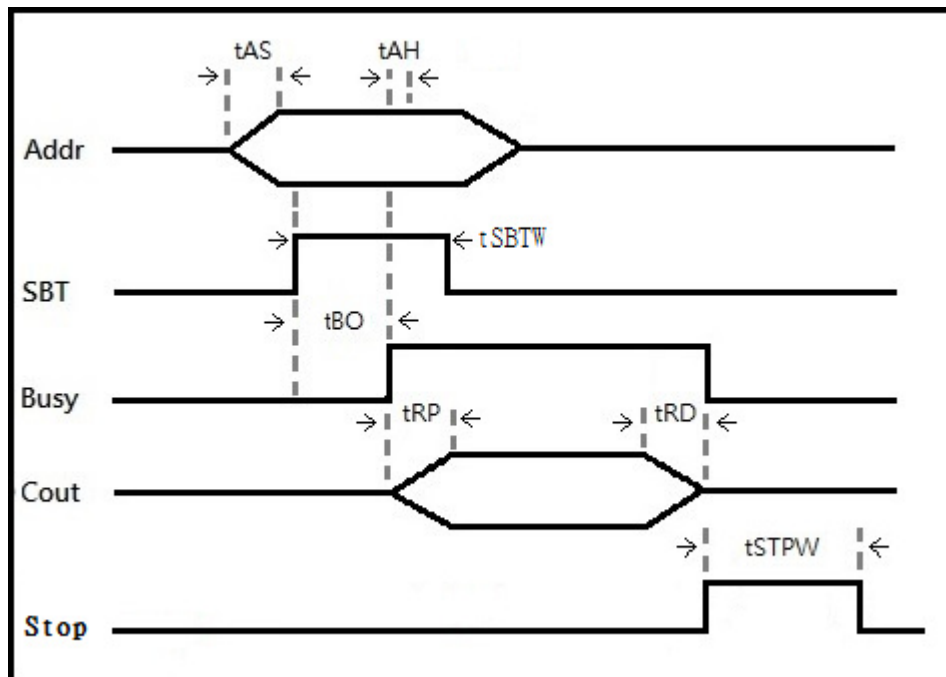

Fig.25

• SPI Mode :

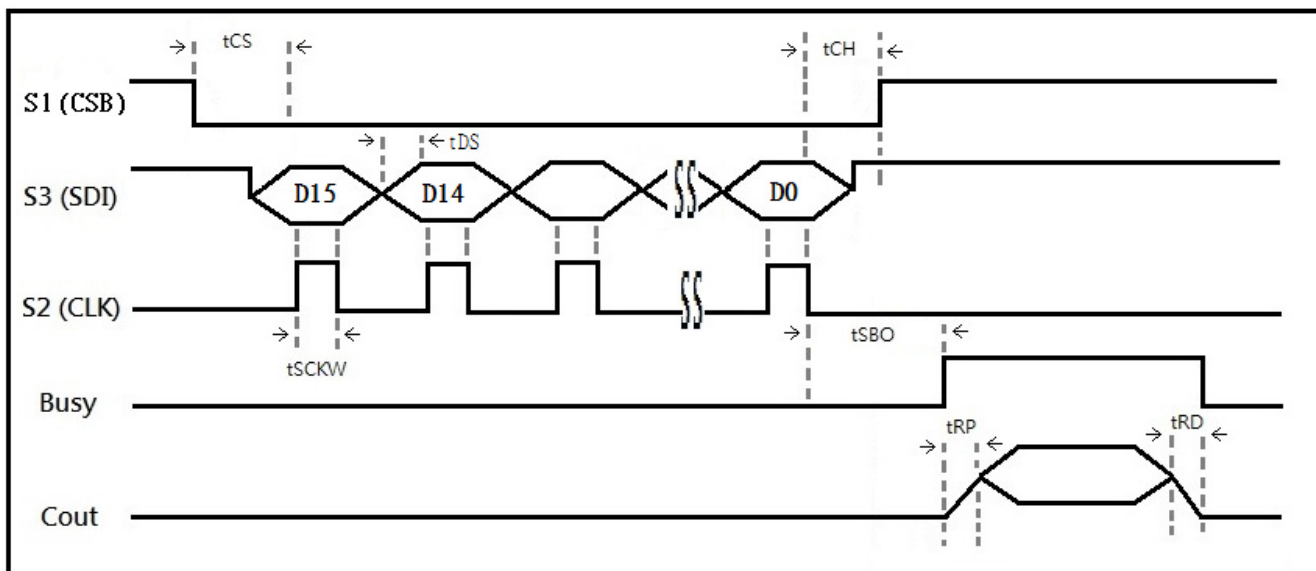

Fig. 26

• I2C Mode :

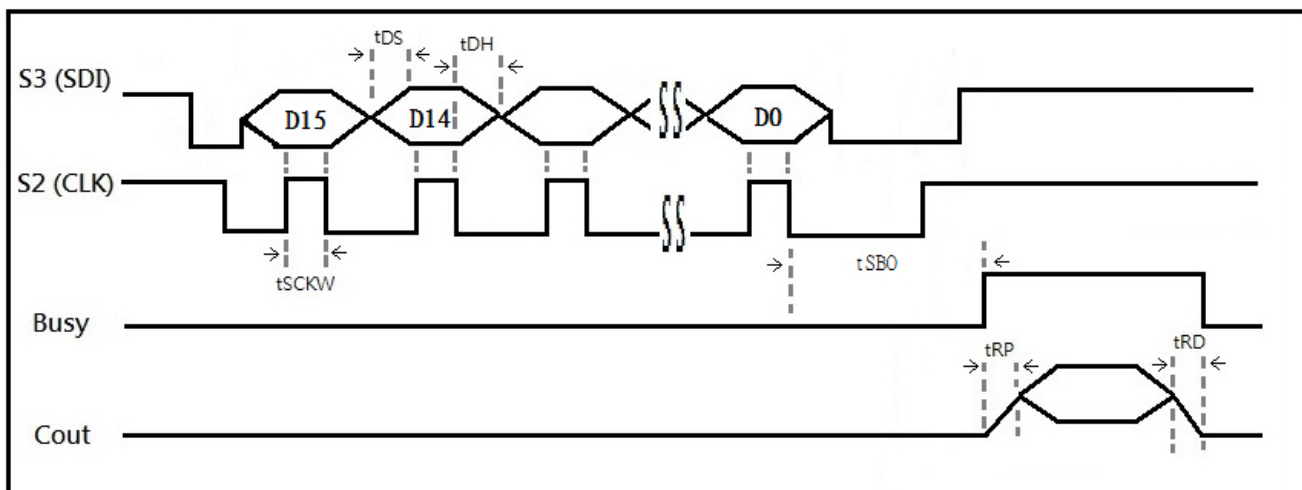

Fig. 27

AC CHARACTERISTICS ($T_A = 0$ to 70°C , $V_{DD} = 3.3\text{V}$, $V_{SS} = 0\text{V}$, 8KHz sampling)

Symbol	Parameter	Min.	Typ.	Max.	Unit	Note
t_{KD}	Key trigger debounce time (long)	—	16	—	ms	1
t_{KD}	Key trigger debounce time (long) – Retrigger during voice playback.	—	24	—	ms	1
t_{KD}	Key trigger debounce time (short)	—	1	—	ms	1
t_{KD}	Key trigger debounce time (short) – Retrigger during voice playback.	—	1.5	—	ms	1
t_{STPW}	STOP pulse width (long)	—	128	—	ms	1
t_{STPW}	STOP pulse width (short)	—	500	—	μs	1
t_{AS}	Address set-up time	300	—	—	ns	
t_{AH}	Address hold time	300	—	—	ns	
t_{SBTW}	SBT stroke pulse width (long)	16	—	—	ms	1
t_{SBTW}	SBT stroke pulse width (short)	1	—	—	ms	1
t_{BO}	BUSY signal output delay time(long)	—	24	—	ms	1
t_{BO}	BUSY signal output delay time(short)	—	1	—	ms	1
t_{CS}	Chip select set-up time	100	—	—	ns	
t_{CH}	Chip select hold time	100	—	—	ns	
t_{SCKW}	Serial clock pulse width	1	—	—	μs	
t_{DS}	Data set-up time	100	—	—	ns	
t_{DH}	Data hold time	100	—	—	ns	
t_{SBO}	BUSY signal output delay time	—	—	2	ms	
t_{RP}	Ramp Up time	—	160	—	ms	
t_{RP}	Ramp Up time at cpu parallel mode	—	20	—	ms	
t_{RD}	Ramp Down time	—	160	—	ms	
t_{RD}	Ramp Down time at cpu parallel mode	—	20	—	ms	
t_{FD}	Full signal output delay time	—	—	2	ms	

Notes :

The long or short debounce time is selectable as whole chip option during Voice Files Compiling.

In Circuit Program Applications :

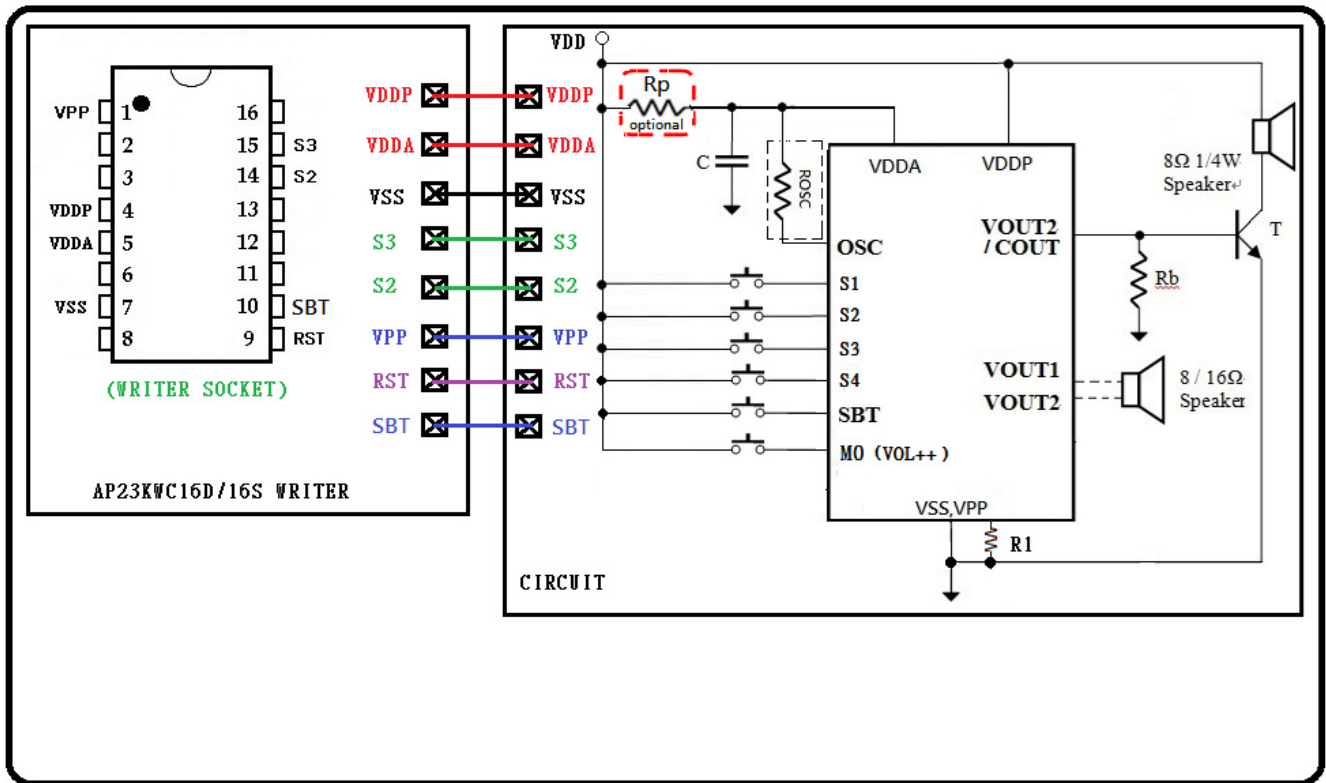

Fig. 28

Note:

1. Between VPP and GND should add R1(10K) Ω .
2. Between Writer and Circuit connect wire less than 10cm is the better.
3. If voltage is higher than 4.0V, C (0.1 μ F_(typ)) is necessary for endure high voltage and protect it from noise which may affect its performance.
Distance between caps and ICs should be minimized to reduce spreading inductance.
The wiring length between the IC and caps may be less than 150mil.
4. Rp is used to filter noise from power line.
 - A. Rp is unnecessary in DAC mode or VDD less than 3.6v.
The value of Rp is 0 ohm in DAC mode.
 - B. If voltage is higher than 3.6V and chip is configured as PWM mode,
Rp is necessary for system stability.
The value of Rp is 56 ohm in PWM mode.
The minimum operating voltage would be lifted from 2.0v to 2.2v, when Rp is added.
 - C. If Rp is added and there is LED drive by OUT1 pin,
please configure the OUT1 pin as active low to drive LED.

▪ **TYPICAL APPLICATIONS :**

Key Mode

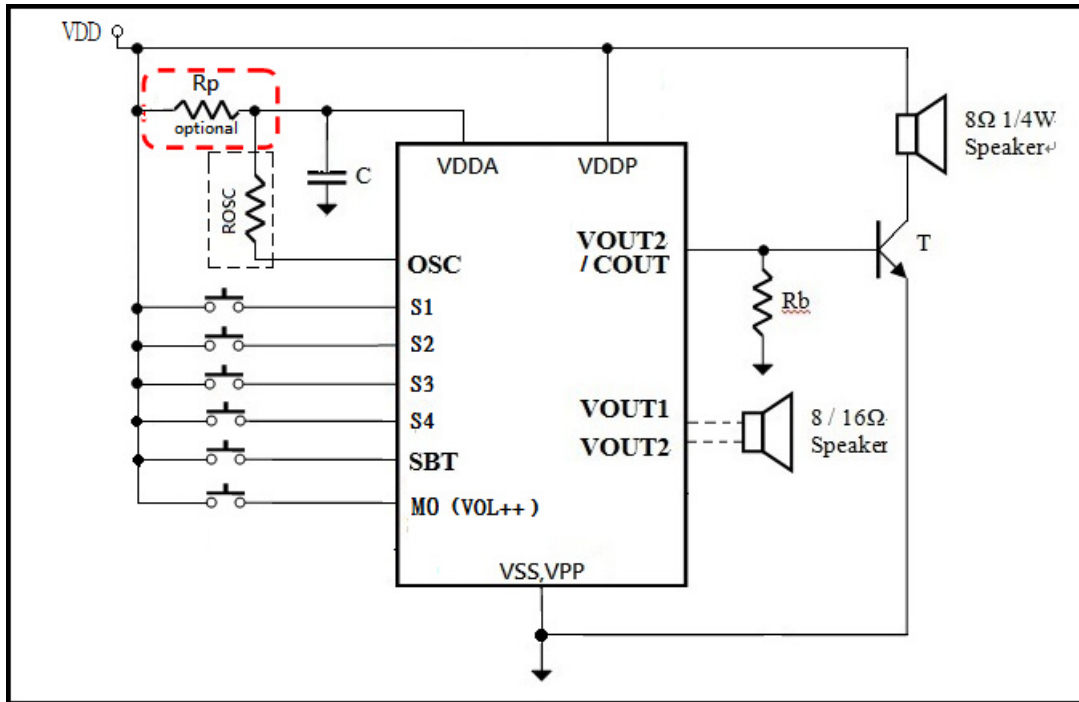

Fig. 29

Note:

- 1 .If voltage is higher than 4.0V, C (0.1uF_(typ)) is necessary for endure high voltage and protect it from noise which may affect its performance.
Distance between caps and ICs should be minimized to reduce spreading inductance.
The wiring length between the IC and caps may be less than 150mil.
2. Rp is used to filter noise from power line.
 - A. Rp is unnecessary in DAC mode or VDD less than 3.6v.
The value of Rp is 0 ohm in DAC mode.
 - B. If voltage is higher than 3.6V and chip is configured as PWM mode,
Rp is necessary for system stability.
The value of Rp is 56 ohm in PWM mode.
The minimum operating voltage would be lifted from 2.0v to 2.2v, when Rp is added.
 - C. If Rp is added and there is LED drive by OUT1 pin,
please configure the OUT1 pin as active low to drive LED.

Ex: Single key control volume.

If volume level is 8 , 1→2→3→4→5→6→7→8→1→2→3→ 4→....

CPU Parallel Mode

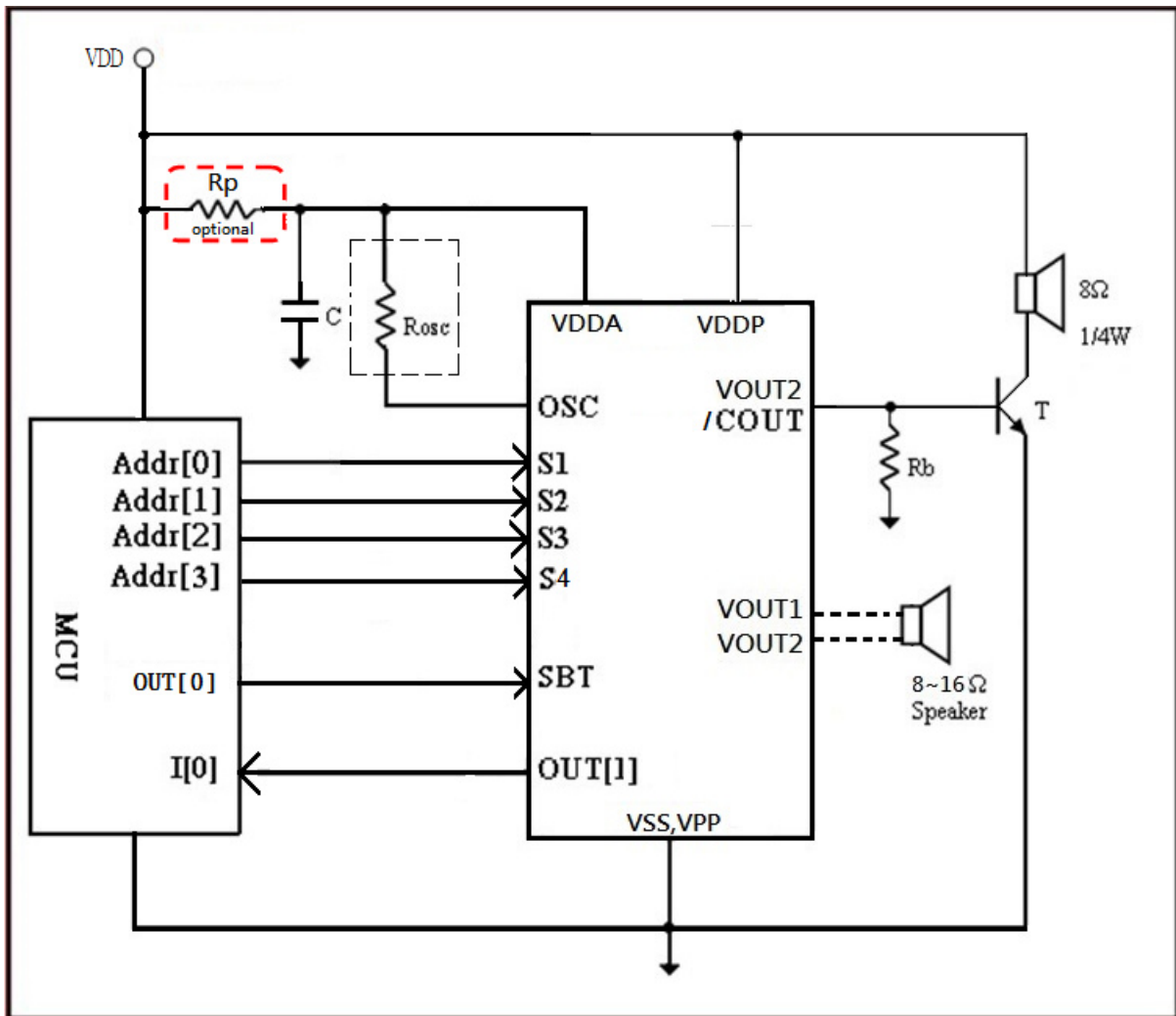

Fig. 30

Note:

1. C is capacitor from 0.1uF to 4.7uF depends on the kind of Vdd source and sound loudness.
2. Rb is base resistor from 120 Ohm to 390 Ohm depends on Vdd value and transistor gain.
3. T is an NPN transistor with beta larger than 150.
4. Reference value for the above components are Rb = 390 Ohm and T = 8050D.
5. If voltage is higher than 4.0V, C (0.1uF_(typ)) is necessary for endure high voltage and protect it from noise which may affect its performance.
Distance between caps and ICs should be minimized to reduce spreading inductance.
The wiring length between the IC and caps may be less than 150mil.
6. Rp is used to filter noise from power line.
 - A. Rp is unnecessary in DAC mode or VDD less than 3.6v.
The value of Rp is 0 ohm in DAC mode.
 - B. If voltage is higher than 3.6V and chip is configured as PWM mode,
Rp is necessary for system stability.
The value of Rp is 56 ohm in PWM mode.
The minimum operating voltage would be lifted from 2.0v to 2.2v, when Rp is added.
 - C. If Rp is added and there is LED drove by OUT1 pin,
please configure the OUT1 pin as active low to drive LED.

SPI Mode

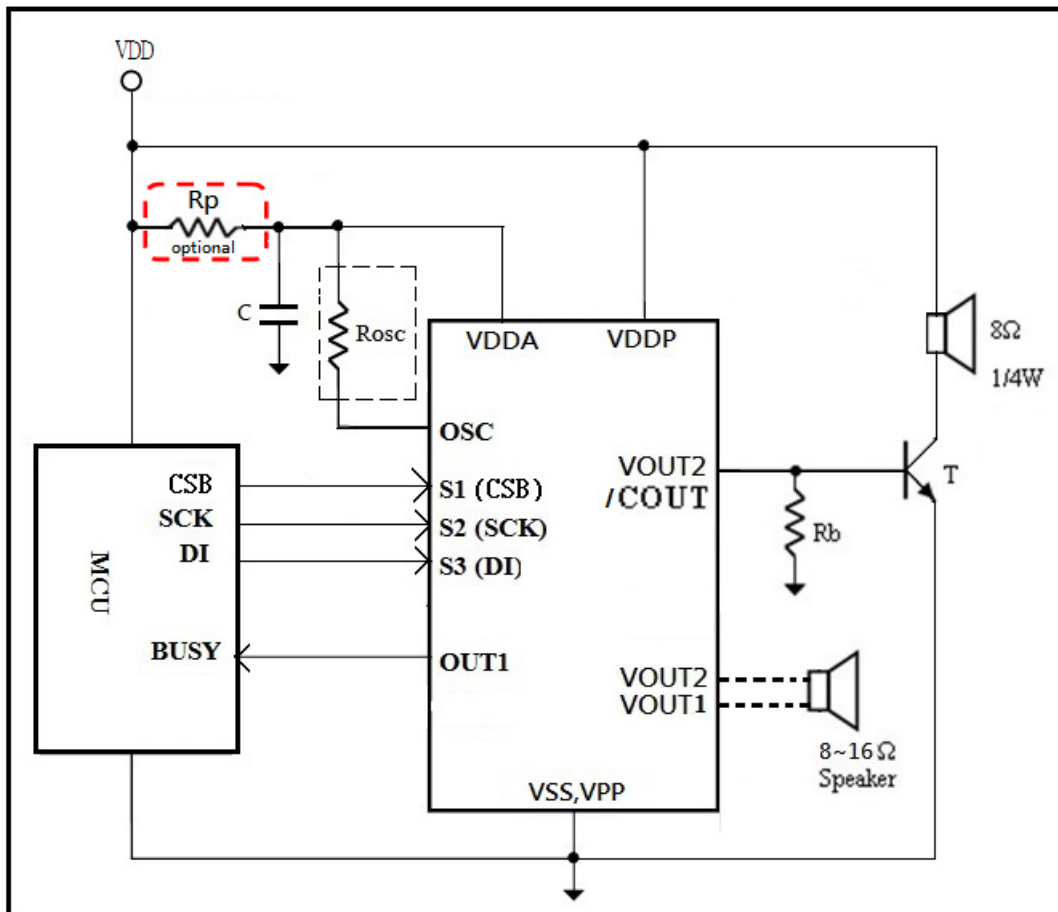

Fig. 31

Note:

1. If voltage is higher than 4.0V, C (0.1uF_(typ)) is necessary for endure high voltage and protect it from noise which may affect its performance.
Distance between caps and ICs should be minimized to reduce spreading inductance.
The wiring length between the IC and caps may be less than 150mil.
2. Rp is used to filter noise from power line.
 - A. Rp is unnecessary in DAC mode or VDD less than 3.6v.
The value of Rp is 0 ohm in DAC mode.
 - B. If voltage is higher than 3.6V and chip is configured as PWM mode,
Rp is necessary for system stability.
The value of Rp is 56 ohm in PWM mode.
The minimum operating voltage would be lifted from 2.0v to 2.2v, when Rp is added.
 - C. If Rp is added and there is LED drive by OUT1 pin,
please configure the OUT1 pin as active low to drive LED.

I2C Mode

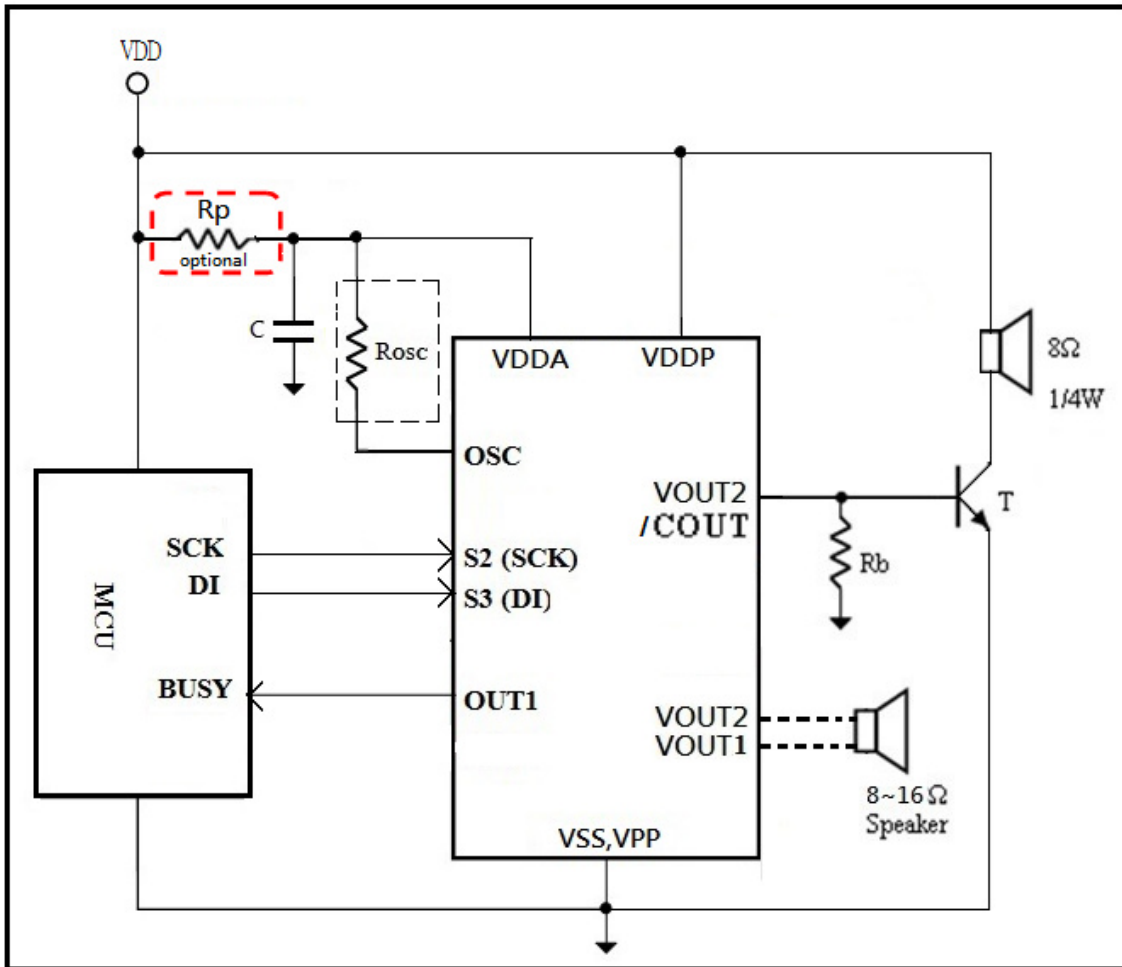

Fig. 32

Note:

1. If voltage is higher than 4.0V, C (0.1uF_(typ)) is necessary for endure high voltage and protect it from noise which may affect its performance.
Distance between caps and ICs should be minimized to reduce spreading inductance.
The wiring length between the IC and caps may be less than 150mil.
2. Rp is used to filter noise from power line.
 - A. Rp is unnecessary in DAC mode or VDD less than 3.6v.
The value of Rp is 0 ohm in DAC mode.
 - B. If voltage is higher than 3.6V and chip is configured as PWM mode,
Rp is necessary for system stability.
The value of Rp is 56 ohm in PWM mode.
The minimum operating voltage would be lifted from 2.0v to 2.2v, when Rp is added.
 - C. If Rp is added and there is LED drove by OUT1 pin,
please configure the OUT1 pin as active low to drive LED.

MP3 Mode

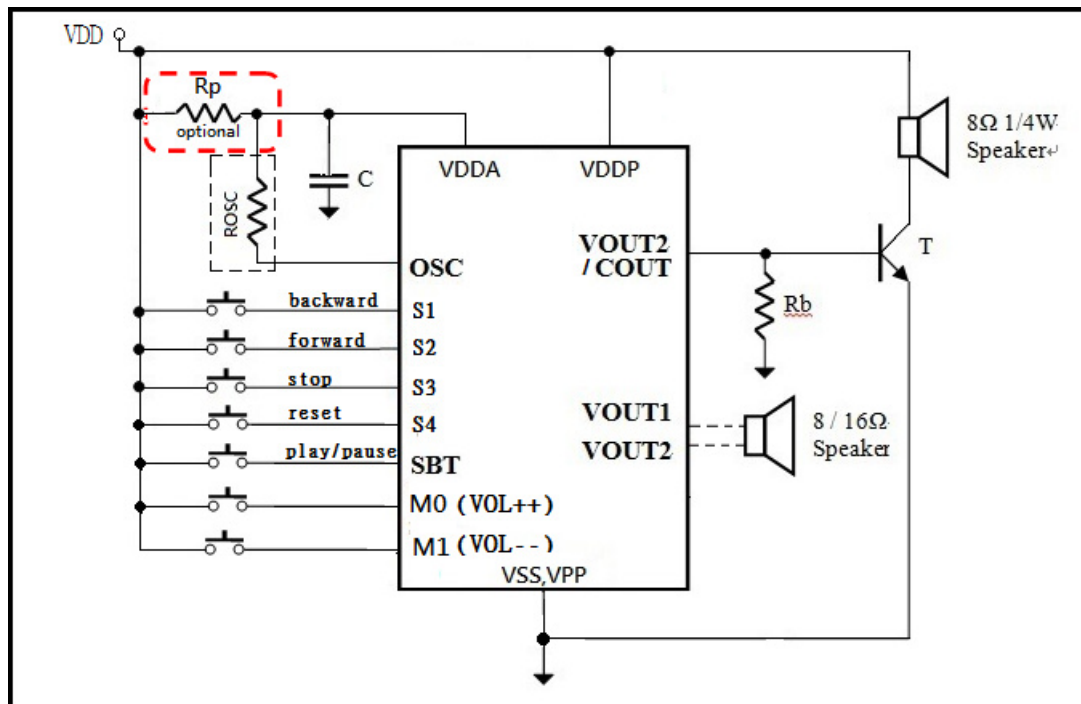
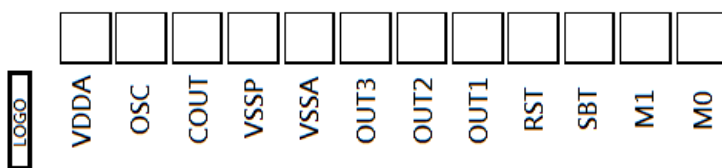
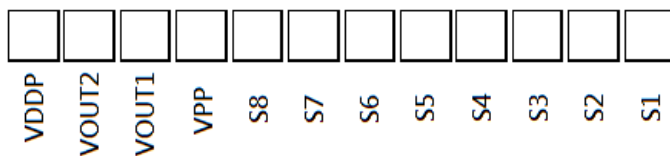
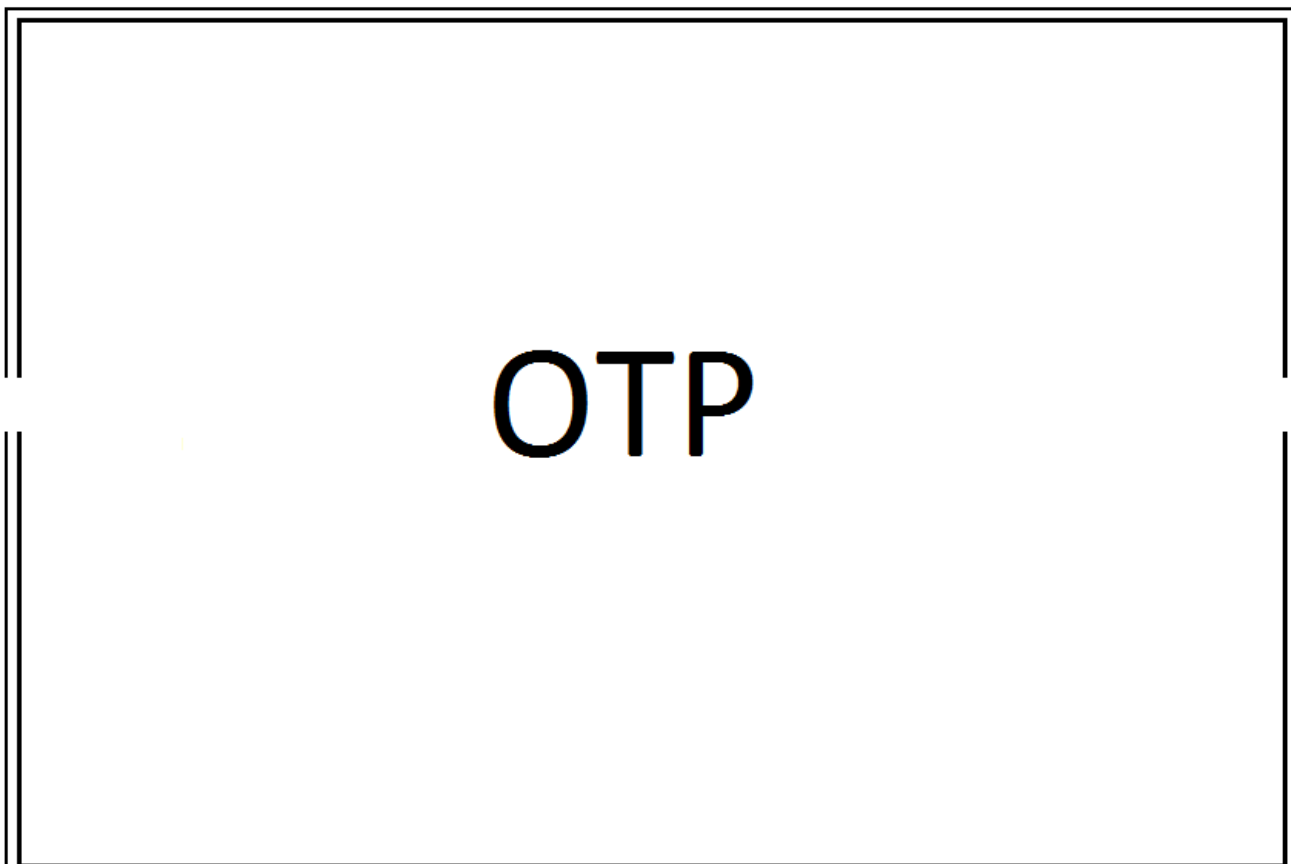

Fig. 33

Note:

- 1 .If voltage is higher than 4.0V, C (0.1uF_(typ)) is necessary for endure high voltage and protect it from noise which may affect its performance.
Distance between caps and ICs should be minimized to reduce spreading inductance.
The wiring length between the IC and caps may be less than 150mil.
2. Rp is used to filter noise from power line.
 - A. Rp is unnecessary in DAC mode or VDD less than 3.6v.
The value of Rp is 0 ohm in DAC mode.
 - B. If voltage is higher than 3.6V and chip is configured as PWM mode,
Rp is necessary for system stability.
The value of Rp is 56 ohm in PWM mode.
The minimum operating voltage would be lifted from 2.0v to 2.2v, when Rp is added.
 - C. If Rp is added and there is LED drive by OUT1 pin,
please configure the OUT1 pin as active low to drive LED.

BONDING PAD DIAGRAMS (aP23682/aP23341)



Notes:

1. Between VPP and GND should add 10KΩ.
2. VDDA and VDDP should be connected to the Positive Power Supply.
3. VSSA and VSSP should be connected to the Power GND.
4. Substrate should be connected to the Power GND.

BONDING PAD DIAGRAMS (aP23170/aP23085)

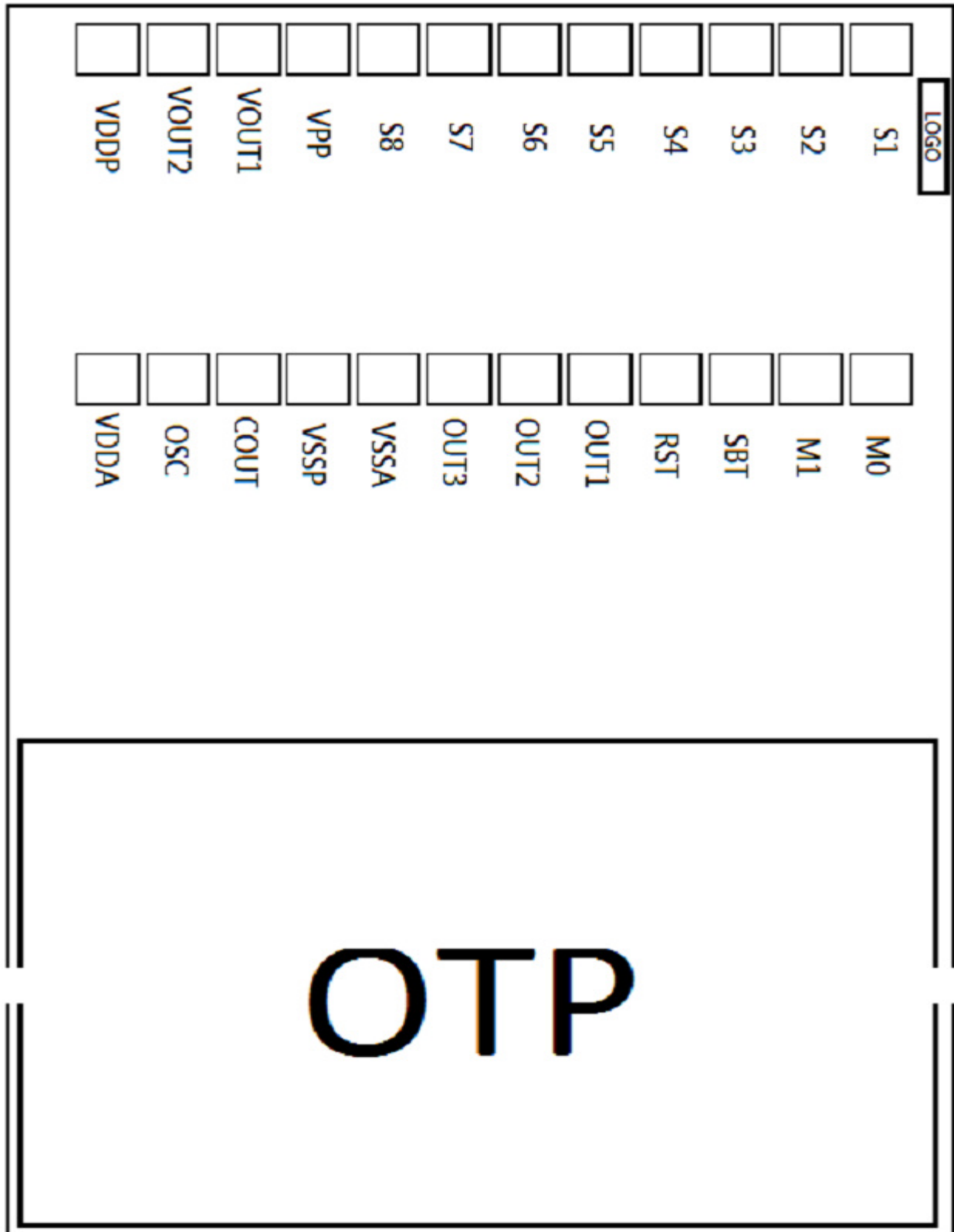

Notes:

1. Between VPP and GND should add 10K Ω .
2. VDDA and VDDP should be connected to the Positive Power Supply.
3. VSSA and VSSP should be connected to the Power GND.
4. Substrate should be connected to the Power GND.

PACKAGES DIMENSION OUTLINES

16-Pin 300mil P-DIP Package

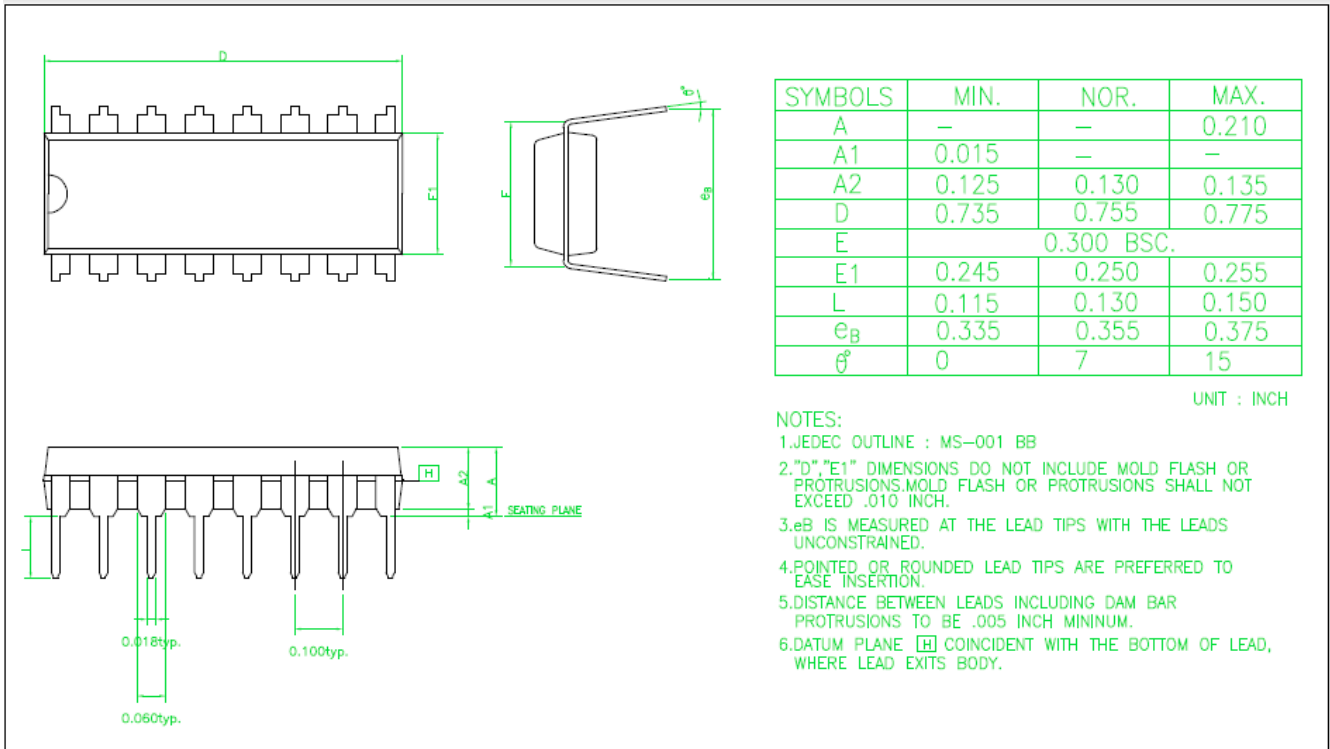

16-Pin 150mil SOP Package

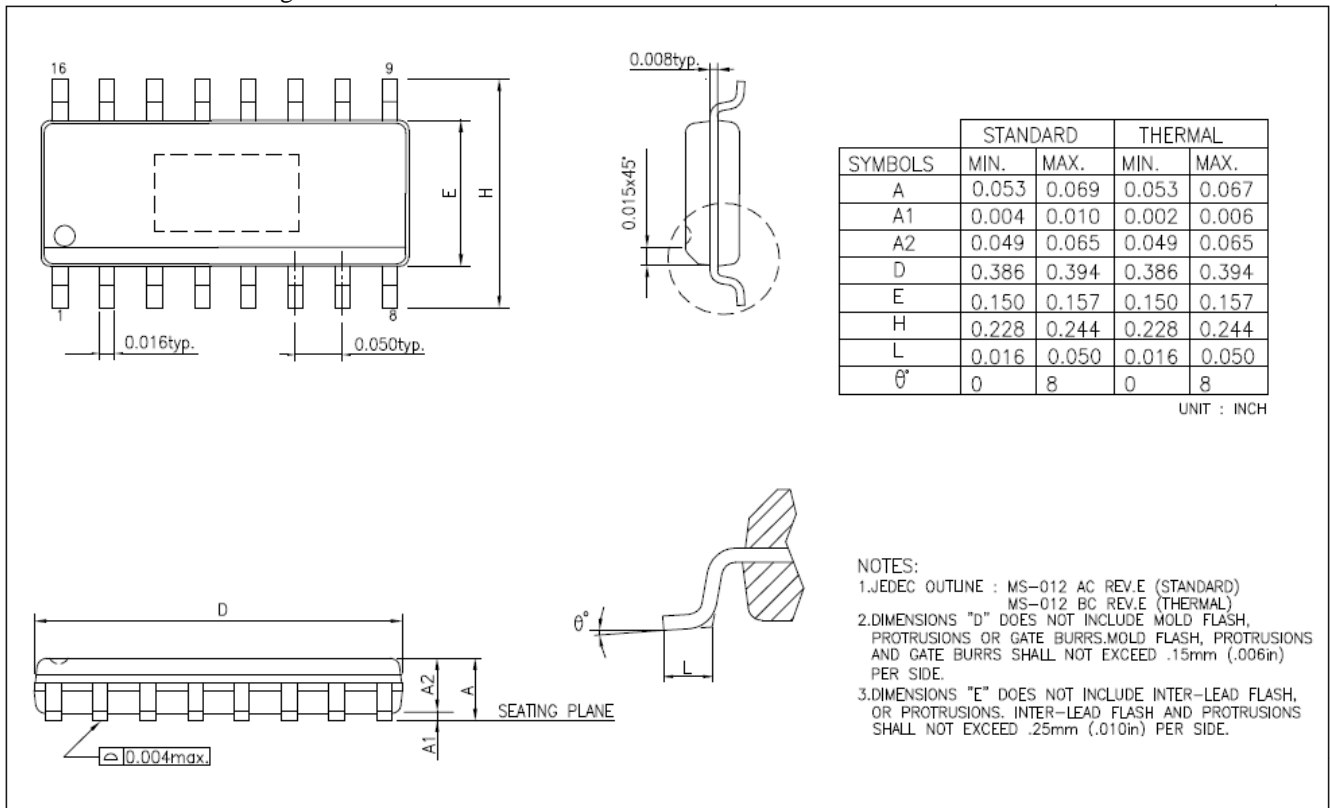

HISTORY

2015/07/20

aP23682_341__170_085 SPEC : Modify cpu control timing waveforms
Modify Page. 17 DC CHARACTERISTICS
Reduce output function from 14 to 9.

2015/09/08

aP23682_341__170_085 SPEC : Modify ULAW5 to ULAW8
Add SBT mode independent description.
Optimize the CPU mode control.
Add In Circuit Program application on page. 29.

2015/12/23

aP23682_341__170_085 SPEC : Add decoupling cap suggestion at high voltage application.
Page 29 to 34.

2016/04/26

aP23682_341__170_085 SPEC : Add Rp to filter noise from power line.
Page 31 to 36.
Add reset circuit for hot plug-in applications.

2016/05/24

aP23682_341__170_085 SPEC : Modify in circuit program schematic to support copier.
Page 4,31.

2017/03/13

aP23682_341__170_085 SPEC : Add a new description in volume control in cpu serial control, its default value would be fixed at "16 level". Page 12.
Remove rewind command of cpu serial. Page 12, 14,16,17,19.
Correct wrong typing in cpu serial command vol++ and vol- -. Page 14,16,17,19.
Modify Fig.11 SPI Command timing change to (CPOL = 0 & CPHA = 0) mode 0
CPOL(clock polarity)=0, the sck idle=0 CPHA(clock phase)=0,the sck low to high (rising)Latch the data(DI)
Fig.12 Power-Up command timing suggest add delay 20us. Page 15.
Fig.16 Power-Up command timing suggest add delay 20us. Page 18.
Fig.20 Change to (CPOL = 0 & CPHA = 0) mode 0. Page 22.
