



# CMX612 Calling Line Identifier with VMWI

D/612/2 August 1999

Advance Information

## Features

- CLI, CIDCW and VMWI System Operation
- CLASS (FSK) and SDT (Stuttered Dial Tone)
- Low Power Operation 0.5mA at 2.7V
- Zero-Power Detector for Ring or Line Reversal
- Low CAS Tone Falsing in CIDCW Mode
- Bellcore, ETSI, BT and Mercury Compatible

## Applications

- CLI and CIDCW Adjunct Boxes
- CLI and CIDCW Feature Phones
- Computer Telephone Integration
- Call Logging Systems
- Voice-Mail Equipment

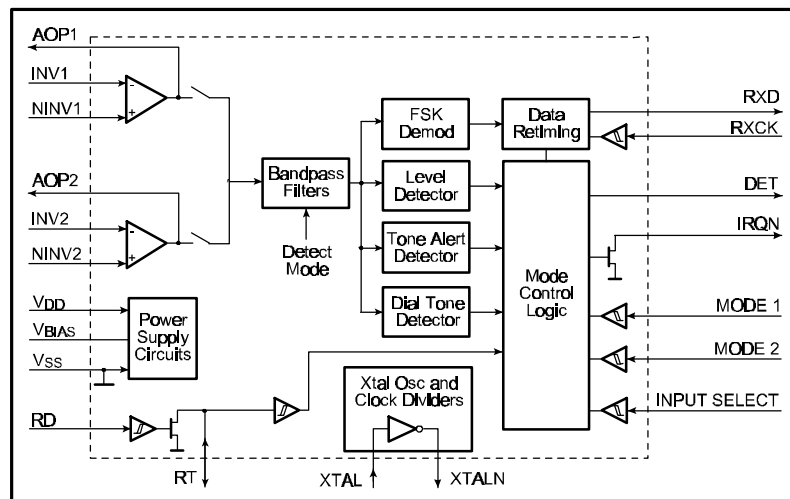

## 1.1 Brief Description

The CMX612 is a low power CMOS integrated circuit for the reception of physical layer signals used in British Telecom's Calling Line Identification Service (CLIP), Bellcore's Calling Identity Delivery system (CID), the Cable Communications Association's Caller Display Services (CDS) and similar evolving systems. It also meets the requirements of emerging Caller Identity with Call Waiting services (CIDCW).

In addition, it provides Visual Message Waiting Indicator (VMWI) detection in both CLASS (FSK) and (SDT) Stuttered Dial Tone modes. Two different signal inputs are provided to the device, to support Tip/Ring and Hybrid connectivity. The device includes a 'zero-power' ring or line reversal detector, a dual-tone (2130Hz plus 2750Hz) Tone Alert Signal detector, a dual-tone (350Hz plus 440Hz) stuttered dial tone detector and a 1200-baud FSK V23/Bell202 compatible asynchronous data demodulator with a data retiming circuit which removes the need for a UART in the associated  $\mu$  Controller.

It is suitable for use in systems to BT specifications SIN227 and SIN242, Bellcore GR-30-CORE and SR-TSV-002476, CCA TW/P&E/312, ETSI ETS 300 659 parts 1 and 2, ETS 300 778 parts 1 and 2 and Mercury Communications MNR 19.

## CONTENTS

<u>Section</u>	<u>Page</u>
<b>1.0 Features and Applications .....</b>	<b>1</b>
<b>1.1 Brief Description.....</b>	<b>1</b>
<b>1.2 Block Diagram .....</b>	<b>3</b>
<b>1.3 Signal List.....</b>	<b>4</b>
<b>1.4 External Components.....</b>	<b>6</b>
<b>1.5 General Description.....</b>	<b>7</b>
<b>1.5.1 Mode Control Logic .....</b>	<b>7</b>
<b>1.5.2 Input Signal Amplifier .....</b>	<b>7</b>
<b>1.5.3 Bandpass Filter .....</b>	<b>8</b>
<b>1.5.4 Level Detector .....</b>	<b>8</b>
<b>1.5.5 FSK Demodulator .....</b>	<b>9</b>
<b>1.5.6 FSK Data Retiming .....</b>	<b>9</b>
<b>1.5.7 Tone Alert Detector .....</b>	<b>10</b>
<b>1.5.8 Dial Tone Detector .....</b>	<b>11</b>
<b>1.5.9 Ring or Line Polarity Reversal Detector .....</b>	<b>11</b>
<b>1.5.10 Xtal Osc and Clock Dividers .....</b>	<b>13</b>
<b>1.6 Application Notes .....</b>	<b>13</b>
<b>1.6.1 'On-Hook' Operation .....</b>	<b>13</b>
<b>1.6.2 'Off-Hook' Operation .....</b>	<b>17</b>
<b>1.6.3 VMWI Operation .....</b>	<b>18</b>
<b>1.7 Performance Specification.....</b>	<b>21</b>
<b>1.7.1 Electrical Performance.....</b>	<b>21</b>
<b>1.7.2 Packaging.....</b>	<b>26</b>

**Note:** This product is in development: Changes and additions will be made to this specification. Items marked TBD or left blank will be included in later issues.

**Information in this data sheet should not be relied upon for final product design.**

## 1.2 Block Diagram

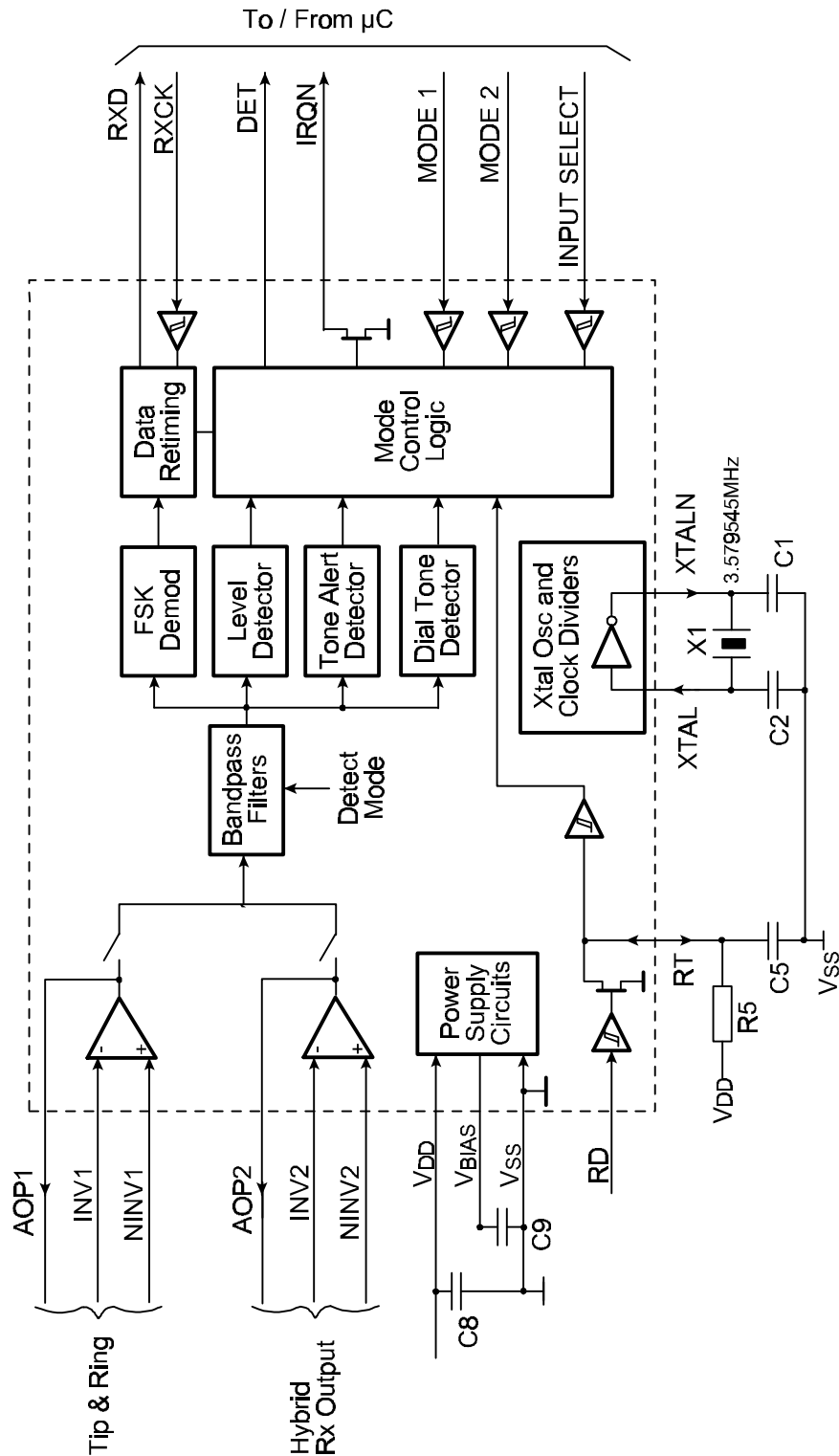

Figure 1 : Block Diagram

### 1.3 Signal List

Package E3	Package P6	Signal		Description
Pin No.	Pin No.	Name	Type	
1	1	XTALN	O/P	The output of the on-chip Xtal oscillator inverter.
2	2	XTAL	I/P	The input to the on-chip Xtal oscillator inverter.
3	3	RD	I/P(S)	Input to the Ring or Line Polarity Reversal Detector.
4	4	RT	BI	Open-drain output and Schmitt trigger input forming part of the Ring or Line Polarity Reversal detector. An external resistor to $V_{DD}$ and a capacitor to $V_{SS}$ should be connected to RT to filter and extend the RD input signal.
5	5	INPUT SELECT	I/P(S)	Controls the selection of the two Input Signal Amplifiers. A low level selects Input 1 and a high level selects Input 2.
6	6	AOP1	BI	The output of on-chip Input Signal Amplifier 1 and an input to the signal selection multiplexer.
7	7	INV1	I/P	The inverting input to on-chip Input Signal Amplifier 1.
8	8	NINV1	I/P	The non-inverting input to on-chip Input Signal Amplifier 1.
9	10	$V_{BIAS}$	O/P	Internally generated bias voltage, held at $\frac{1}{2} V_{DD}$ when the device is not in 'Zero-Power' mode. Should be decoupled to $V_{SS}$ by a capacitor mounted close to the device pins.
10	11	$V_{SS}$	Power	Negative supply rail (signal ground).
11	12	NINV2	I/P	The non-inverting input to on-chip Input Signal Amplifier 2.
12	13	INV2	I/P	The inverting input to on-chip Input Signal Amplifier 2.
13	14	AOP2	BI	The output of on-chip Input Signal Amplifier 2 and an input to the signal selection multiplexer.
14	15	MODE 2	I/P(S)	Input used to select the operating mode. See Section 1.5.1.
15	16	MODE 1	I/P(S)	As per MODE 2 description.

Package E3	Package P6	Signal		Description
Pin No.	Pin No.	Name	Type	
16	17	IRQN	O/P	An open-drain active low output that may be used as an Interrupt Request/Wake-up input to the associated $\mu$ C. An external pull-up resistor should be connected between this output and $V_{DD}$ .
17	18	DET	O/P	A logic level output driven by the Ring or Line Polarity Reversal Detector, the Tone Alert Detector, the Dial Tone Detector or the FSK Level detect circuits, depending on the operating mode. See Section 1.5.1.
18	19	RXCK	I/P(S)	An input which may be used to clock received data bits out of the FSK Data Retiming block.
19	21	RXD	O/P	A logic level output carrying either the raw output of the FSK Demodulator or re-timed 8-bit characters depending on the state of the RXCK input. See Section 1.5.6.
20	22	$V_{DD}$	Power	The positive supply rail. Levels and thresholds within the device are proportional to this voltage. Should be decoupled to $V_{SS}$ by a capacitor mounted close to the device pins.
	9, 20			Not used. Do not connect to these pins.

**Notes:** I/P = Input  
 I/P(S) = Schmitt trigger input  
 O/P = Output  
 BI = Bidirectional

### 1.4 External Components

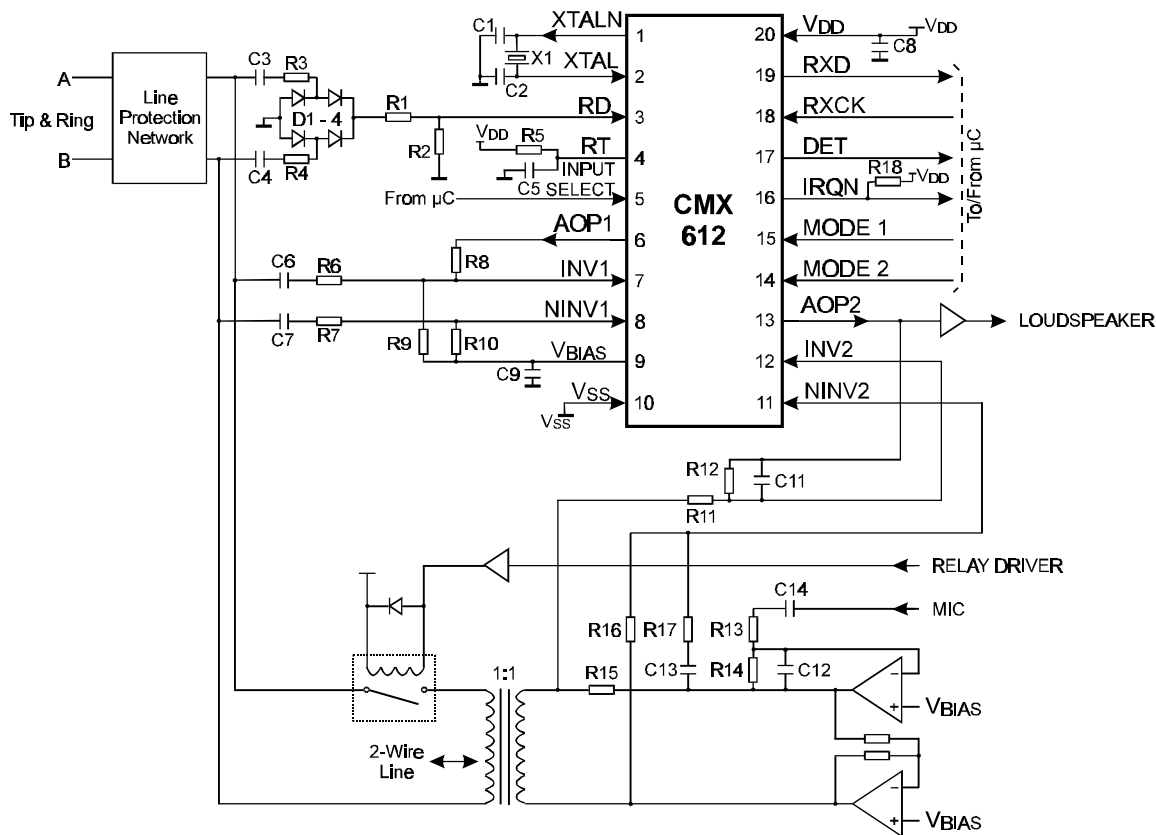

R1	470kΩ	C1, C2	18pF
R2	See Section 1.5.8	C3, C4	0.1μ F
R3, R4, R5	470kΩ	C5	0.33μ F
R6, R7	470kΩ	C6, C7	680pF
R8	470kΩ for V <sub>DD</sub> = 3.3V 680kΩ for V <sub>DD</sub> = 5.0V (See Section 1.5.2)	C8, C9	0.1μ F
R9	240kΩ for V <sub>DD</sub> = 3.3V 200kΩ for V <sub>DD</sub> = 5.0V (See Section 1.5.2)	C11, C12	330pF
R10	160kΩ	C13	10nF
R11 - R14	100kΩ	C14	100nF
R15	600Ω	X1	3.579545MHz
R16	120kΩ	D1 - D4	1N4004
R17	100kΩ		
R18	100kΩ ±20%		

Resistors ±1%, capacitors ±20% unless otherwise stated.

**Figure 2 : Recommended External Components for Typical Application**

It is recommended that the printed circuit board is laid out with a ground plane in the CMX612 area to provide a low impedance ground connection to the V<sub>SS</sub> pin and to the decoupling capacitors C8 and C9.

## 1.5 General Description

### 1.5.1 Mode Control Logic

The CMX612's operating mode and the source of the DET and IRQN outputs are determined by the logic levels applied to the MODE 1 and MODE 2 input pins;

MODE 1	MODE 2	Mode	DET o/p from	IRQN o/p from
0	0	Tone Alert Detect	Tone Alert Signal Detection. CAS tones present.	Valid 'off-hook' CAS or Ring or Line Polarity Reversal Detection. Ringing Signal present.
0	1	FSK Receive	FSK Level Detection. FSK present.	FSK Data Retiming <sup>[1]</sup> or Ring or Line Polarity Reversal Detection. Ringing Signal present.
1	0	'Zero-Power'	Ring or Line Polarity Reversal Detection. Ringing Signal present.	Ring or Line Polarity Reversal Detection. Ringing Signal present.
1	1	Dial Tone Detect	Dial Tone Signal Detection. Both tones present.	Valid dial tone detected.

[1] If enabled.

In 'Zero-Power' mode, power is removed from all of the internal circuitry except for the Ring or Line Polarity Reversal Detector and the DET and IRQN outputs.

### 1.5.2 Input Signal Amplifiers

These amplifiers can be used to convert the balanced FSK, Tone Alert and VMWI signals received over the telephone line to an unbalanced signal of the correct amplitude for the FSK receiver, Tone Alert and Dial Tone Detector circuits.

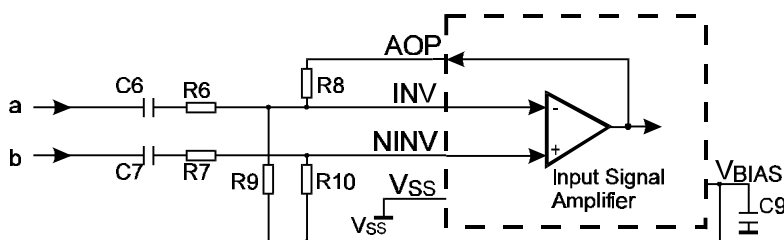

Figure 3a : Input Signal Amplifier, balanced input configuration

The design equations for this circuit are;

$$\begin{aligned}
 \text{Differential voltage gain } V_{AOP} / V(b-a) &= R8/R6 \\
 R6 &= R7 = 470k\Omega \\
 R10 &= 160k\Omega \\
 R9 &= R8 \times R10 / (R8 - R10)
 \end{aligned}$$

The target differential voltage gain depends on the expected signal levels between the A and B wires and the CMX612's internal threshold levels, which are proportional to the supply voltage.

The CMX612 has been designed to meet the applicable specifications with  $R8 = 430k\Omega$  at  $V_{DD} = 3.0V$  nominal, rising to  $680k\Omega$  at  $V_{DD} = 5.0V$ , and  $R9$  should be  $240k\Omega$  at  $V_{DD} = 3.0V$  and  $200k\Omega$  at  $V_{DD} = 5.0V$  as shown in Section 1.4 and Figure 3c.

The Input Signal Amplifiers may also be used with an unbalanced signal source as shown in Figure 3b. The values of  $R6$  and  $R8$  are as for the balanced input case.

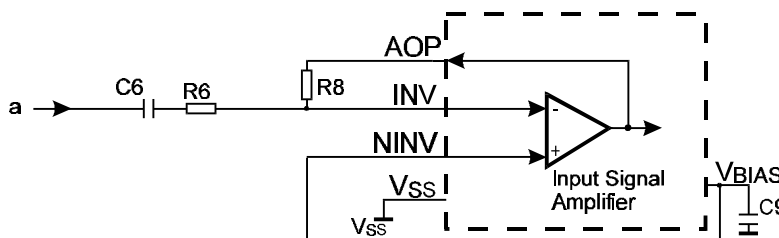

**Figure 3b : Input Signal Amplifier, unbalanced input configuration**

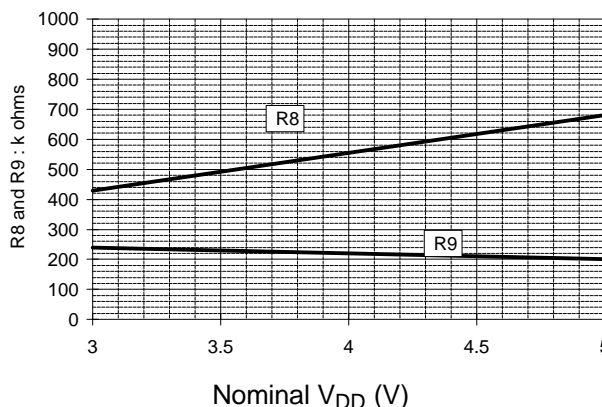

**Figure 3c : Input Signal Amplifier, optimum values of  $R8$  and  $R9$  vs.  $V_{DD}$**

### 1.5.3 Bandpass Filters

These are used to attenuate out of band noise and interfering signals which might otherwise reach the FSK Demodulator, Tone Alert Detector, Dial Tone detector and Level Detector circuits. The characteristics of these filters differ in FSK, Tone Alert and Dial Tone modes. Most of the filtering is provided by switched capacitor stages clocked at 57.7kHz or 9.62kHz depending on mode of operation.

### 1.5.4 Level Detector

This block operates by measuring the level of the signal at the output of the Bandpass Filter, and comparing it against a threshold which depends on whether FSK Receive, Tone Alert Detect or Dial Tone Detect mode has been selected.

In Tone Alert Detect mode the output of the Level Detector block provides an input to the Tone Alert Signal Detector.

In Dial Tone Detect mode the output of the Level Detector block provides an input to the Dial Tone Signal Detector.



In FSK Receive mode the CMX612 DET output will be set high when the level has exceeded the threshold for sufficient time. Amplitude and time hysteresis are used to reduce chattering of the DET output in marginal conditions.

Note that in FSK Receive mode this circuit may also respond to non-FSK signals such as speech.

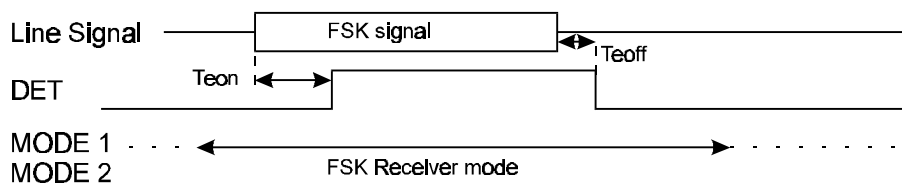

See Section 1.7.1 for definitions of Teon and Teoff

**Figure 4 : FSK Level Detector operation**

### 1.5.5 FSK Demodulator

This block converts the 1200 baud FSK input signal to a logic level received data signal which is output via the RXD pin as long as the Data Retiming function is not enabled (see Section 1.5.6). This output does not depend on the state of the FSK Level Detector output.

Note that in the absence of a valid FSK signal, the demodulator may falsely interpret speech or other extraneous signals as data.

### 1.5.6 FSK Data Retiming

The Data Retiming block extracts the 8 data bits of each character from the received asynchronous data stream, and presents them to the  $\mu$ C under the control of strobe pulses applied to the RXCK input. The timing of these pulses is not critical and they may easily be generated by a simple software loop. This facility removes the need for a UART in the  $\mu$ C without incurring an excessive software overhead.

The block operates on a character by character basis by first looking for the mark to space transition which signals the beginning of the start bit, then, using this as a timing reference, sampling the output of the FSK Demodulator in the middle of each of the following 8 received data bits, storing the results in an internal 8-bit shift register.

When the eighth data bit has been clocked into the internal shift register, the CMX612 examines the RXCK input. If this is low then the IRQN output will be pulled low and the first of the stored data bits put onto the RXD output pin. On detecting that the IRQN output has gone low, the  $\mu$ C should pulse the RXCK pin high 8 times. The high to low transition at the end of the first 7 of these pulses will be used by the CMX612 to shift the next data bit from the shift register onto the RXD output. At the end of the eighth pulse the FSK Demodulator output will be reconnected to the RXD output pin. The IRQN output will be cleared the first time the RXCK input goes high.

Thus to use the Data Retiming function, the RXCK input should be kept low until the IRQN output goes low; if the Data Retiming function is not required the RXCK input should be kept high.

The only restrictions on the timing of the RXCK waveform are those shown in Figure 5a and the need to complete the transfer of all eight bits into the  $\mu$ C within 8.3ms (the time of a complete character at 1200 baud).

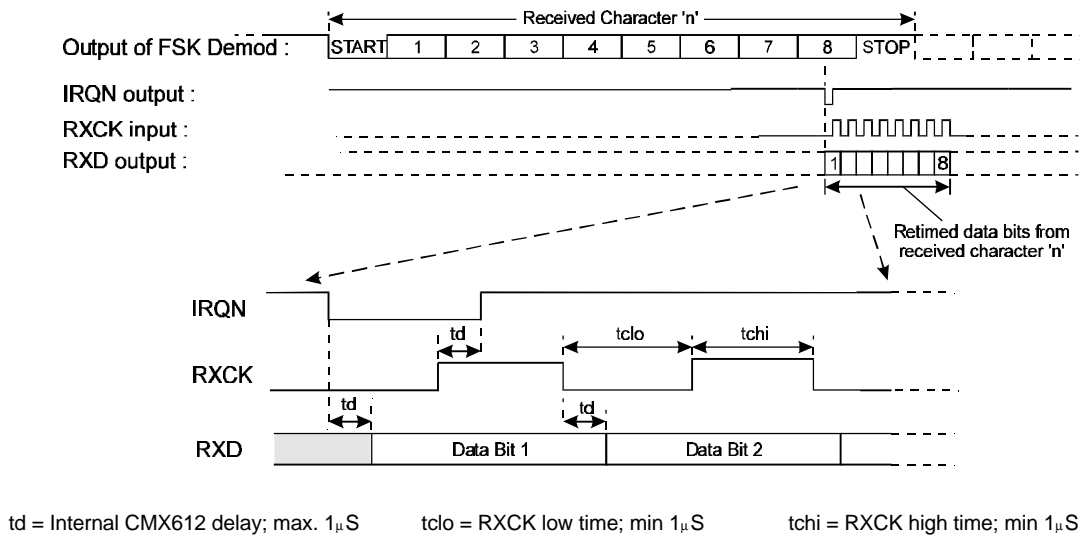

**Figure 5a : FSK Operation With Data Retiming**

Note that, if enabled, the Data Retiming block will interpret the FSK Channel Seizure signal (a sequence of alternating mark and space bits) as valid received characters, with values of 55 (hex). Similarly it may interpret speech or other signals as random characters.

If the Data Retiming facility is not required, the RXCK input to the CMX612 should be kept high. The asynchronous data from the FSK Demodulator will then be connected directly to the RXD output pin, and the IRQN output will not be activated by the FSK signal. This case is illustrated in Figure 5b.

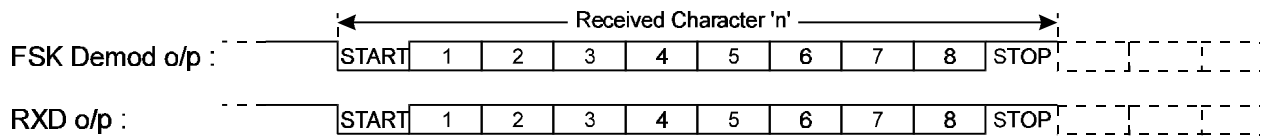

**Figure 5b : FSK Operation Without Data Retiming (RXCK always high)**

**1.5.7 Tone Alert Detector**

This block is enabled when the CMX612 is set to Tone Alert Detect mode. It will then monitor the received signal for the presence of simultaneous 2130Hz and 2750Hz tones of sufficient level and duration.

Two digital bandpass filters, centred around 2130Hz and 2750Hz, are used within the block to give additional rejection of interfering signals.

The CMX612 DET output will be set high while a Tone Alert signal is detected.

When the DET output goes low at the end of the Tone Alert signal, then if the DET output had been high for a time within the CAS qualifying time TqCAS limits (see Section 1.7.1) , then the IRQN output will be pulled low and will remain low until the CMX612 is switched out of Tone Alert Detect mode. Note that the TqCAS timing has been optimised for the detection of 75 to 85ms Tone Alert (CAS) signals used in off-hook applications, the longer (88 to 110ms) Tone Alert signal employed by BT for on-hook applications will not necessarily cause IRQN to go low.

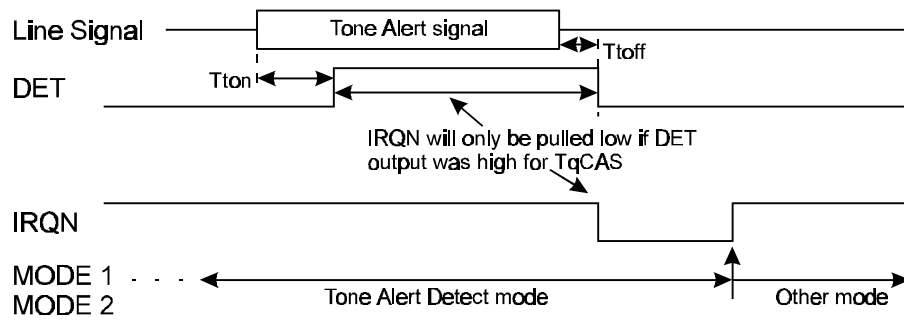

See Section 1.7.1 for definitions of Tton, Ttoff and TqCAS

**Figure 6 : Tone Alert Detector operation**

**1.5.8 Dial Tone Detector**

This block is enabled when the CMX612 is set to Dial Tone Detect mode. It will then monitor the received signal for the presence of simultaneous 350Hz and 440Hz tones of sufficient level and duration.

Two digital bandpass filters, centred around 350Hz and 440Hz, are used within the block to give additional rejection of interfering signals. The CMX612 DET output will be set high while a Dial Tone signal is detected.

When the DET output goes high the IRQN output will be pulled low and will remain low until the CMX612 is switched out of Dial Tone Detect mode. Note that the Dial Tone Detect timing has been optimised for the detection of >90ms signals. Shorter dial tone signals will not necessarily be detected.

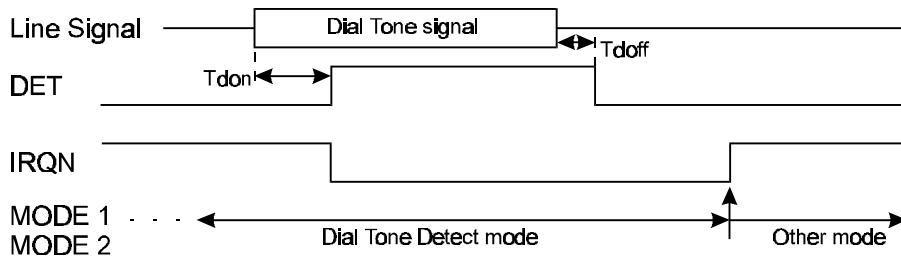

See Section 1.7.1 for definitions of Tdon and Tdoff

**Figure 7 : Dial Tone Detector operation**

**1.5.9 Ring or Line Polarity Reversal Detector**

These circuits are used to detect the Line Polarity Reversal and Ringing signals associated with the Calling Line Identification protocol.

Figure 8 illustrates their use in a typical application.

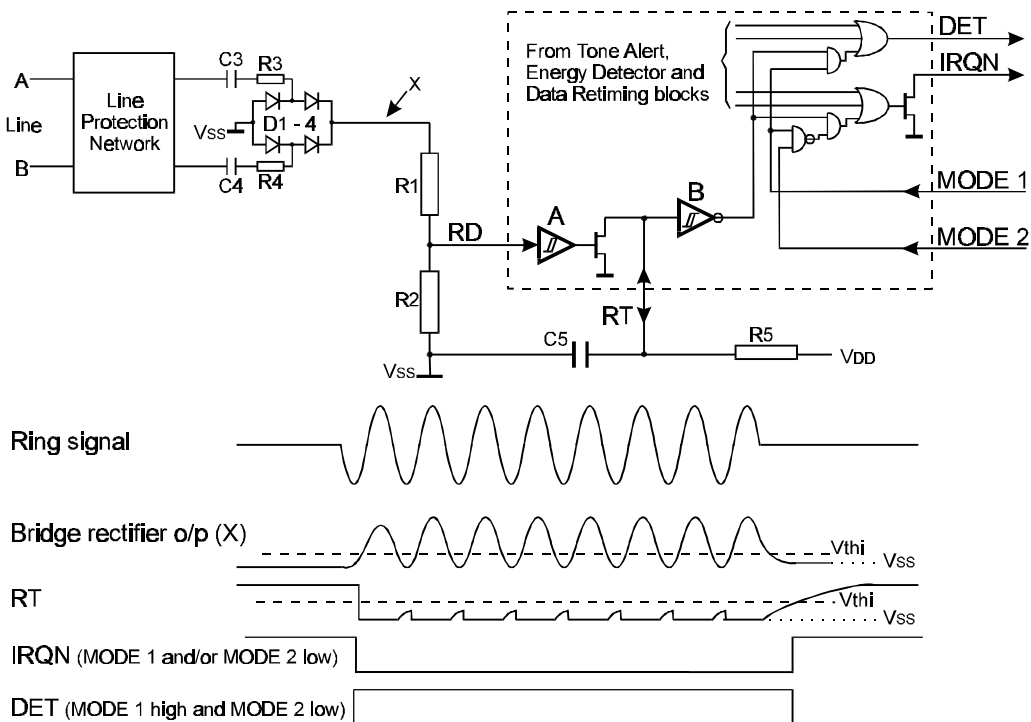

**Figure 8 : Ring or Line Polarity Reversal operation**

When no signal is present on the telephone line, RD will be at V<sub>SS</sub> and RT pulled to V<sub>DD</sub> by R5 so the output of the Schmitt trigger 'B' will be low.

The ring signal is usually applied at the subscriber's exchange as an ac voltage inserted in series with one of the telephone wires and will pass through either C3 and R3 or C4 and R4 to appear at the top end of R1 (point X in Figure 8) in a rectified and attenuated form.

The signal at point X will be further attenuated by the potential divider formed by R1 and R2 before being applied to the CMX612 input RD . If the amplitude of the signal appearing at RD is greater than the input threshold (V<sub>thi</sub>) of Schmitt trigger 'A' then the N transistor connected to RT will be turned on, pulling the voltage at RT to V<sub>SS</sub> by discharging the external capacitor C5. The output of the Schmitt trigger 'B' will then go high, activating the DET and/or IRQN outputs depending on the states of the MODE 1 and MODE 2 inputs.

The minimum amplitude ringing signal that is certain to be detected is:

$$( 0.7 + V_{thi} \times [R1 + R2 + R3] / R2 ) \times 0.707 \text{ Vrms}$$

where V<sub>thi</sub> is the high-going threshold voltage of the Schmitt trigger A (see Section 1.7).

With R1, R3 and R4 all at 470k $\Omega$ , as Figure 2, setting R2 to 68k $\Omega$  will guarantee detection of ringing signals of 40Vrms and above for V<sub>DD</sub> over the range 2.7 to 5.5V.

A line polarity reversal may be detected using the same circuit but there will be only one pulse at RD. The BT specification SIN242 says that the circuit must detect a +15V to -15V reversal between the two lines slewing in 30ms. For a linearly changing voltage at the input to C3 (or C4), then the voltage appearing at the RD pin will be:

$$dV/dt \times C3 \times [ 1 - \exp(-t/T) ] \times R2$$

where T = C3 x (R1 + R2 + R3) and dV/dt is the input slew rate.

For  $dV/dt = 500V/sec$  (15V in 30ms), R1, R3 and R4 all  $470k\Omega$  and C3, C4 both  $0.1\mu F$  as Figure 2, then setting R2 to  $390k\Omega$  will guarantee detection at  $V_{DD} = 5.5V$ .

If the time constant of R5 and C5 is large enough then the voltage on RT will remain below the threshold of the 'B' Schmitt trigger keeping the DET and/or IRQN outputs active for the duration of a ring cycle.

The time for the voltage on RT to charge from  $V_{SS}$  towards  $V_{DD}$  can be derived from the formula

$$V_{RT} = V_{DD} \times [1 - \exp(-t/(R5 \times C5)) ]$$

As the Schmitt trigger high-going input threshold voltage ( $V_{thi}$ ) has a minimum value of  $0.56 \times V_{DD}$ , then the Schmitt trigger B output will remain high for a time of at least  $0.821 \times R5 \times C5$  following a pulse at RD.

Using the values given in Figure 2 ( $470k\Omega$  and  $0.33\mu F$ ) gives a minimum time of 100 ms (independent of  $V_{DD}$ ), which is adequate for ring frequencies of 10Hz or above.

If necessary, the  $\mu C$  can distinguish between a ring and a reversal by timing the length of the IRQN or DET output.

### 1.5.10 Xtal Osc and Clock Dividers

Frequency and timing accuracy of the CMX612 is determined by a 3.579545MHz clock present at the XTAL pin. This may be generated by the on-chip oscillator inverter using the external components C1, C2 and X1 of Figure 2, or may be supplied from an external source to the XTAL input, in which case C1, C2 and X1 should not be fitted.

The oscillator is turned off in 'Zero-Power' mode.

If the clock is provided by an external source which is not always running, then the MODE 1 input must be set high and the MODE 2 input must be set low when the clock is not available. Failure to observe this rule may cause a significant rise in the supply current drawn by CMX612 as well as generating undefined states of the RXD, DET and IRQN outputs.

## 1.6 Application Notes

### 1.6.1 'On-Hook' Operation

The systems described in this section operate when the telephone set is not in use (on-hook) to display the number of a calling party before the call is answered.

#### British Telecom System

Figure 9a illustrates the line signalling and CMX612 I/O signals for the BT on-hook Calling Line ID system as defined in BT specifications SIN227 and SIN242 part 1. A similar system is described in ETS 300 659-1 Section 6.1.2c. and ETS 300 778-1.

The Tone Alert signal consists of simultaneous 2130Hz and 2750Hz tones, the 'Chan Seize' signal is a '1010..' FSK bit sequence. Not shown are the requirements for ac and dc loads, including a short initial Current Wetting Pulse, to be applied to the line 20ms after the end of the Tone Alert signal and to be maintained during reception of the FSK signal. Note that, for simplicity of presentation, the Data Retiming function is not used in Figure 9a (RXCK is kept high).

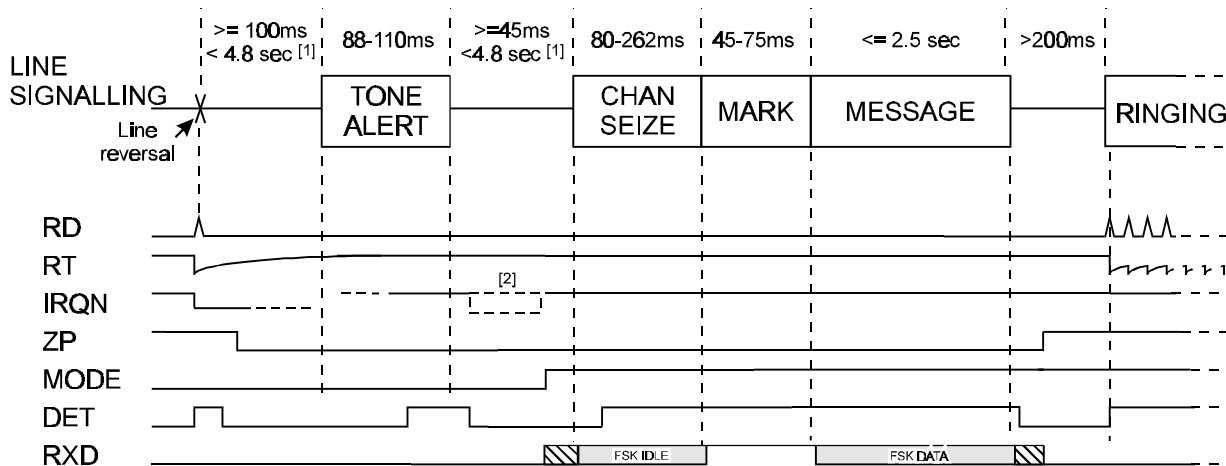

[1] Sum of these two periods does not exceed 5 sec  
 [2] IRQN may go low at end of DET high period, but this is not guaranteed.

Figure 9a : BT On-hook System Signals

**Bellcore System**

Figure 9b illustrates the line signalling and CMX612 I/O signals for the Bellcore on-hook Caller ID system as defined in Bellcore documents GR-30-CORE and SR-TSV-002476 and also in ETS 300 659-1 Section 6.1.1. and ETS 300 778-1.

As for the BT system, the 'Chan Seize' signal is a '1010..' FSK bit sequence. The Bellcore specifications do not require ac or dc line terminations while the FSK data is being received, however ETS 300 659-1 and ETS 300 778-1 allow for the possibility of an ac termination being applied. Note that, for simplicity of presentation, the Data Retiming function is not used in Figure 9b (RXCK is kept high).

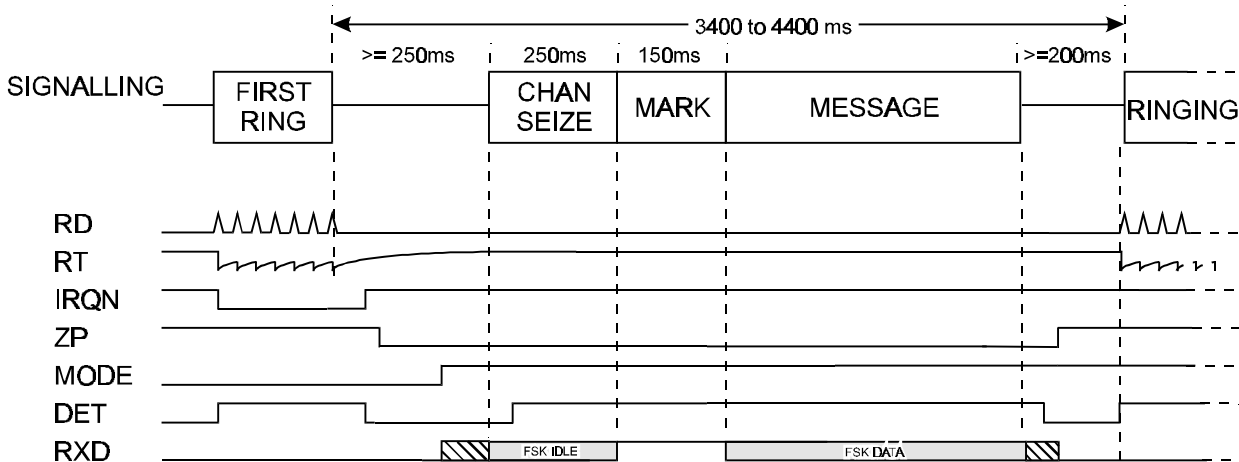

Figure 9b : Bellcore On-hook System Signals

### **Other On-hook Systems**

ETS 300 659-1 and ETS 300 778-1 also allow for systems where the FSK transmission is preceded by a Dual Tone Alerting signal similar to that used by BT but without a line reversal (Section 6.1.2a) or by a Ringing Pulse Alerting Signal (Section 6.1.2b).

The U.K. CCA (Cable Communications Association) specification TW/P&E/312 precedes the FSK signals by a 200 to 450ms ring burst. The use of ac and dc line terminations during FSK reception is optional.

Mercury Communications Ltd. specification MNR 19 allows for either the BT system or that specified by CCA.

As these are all slight variants on the BT and Bellcore systems, they can also be handled by the CMX612.

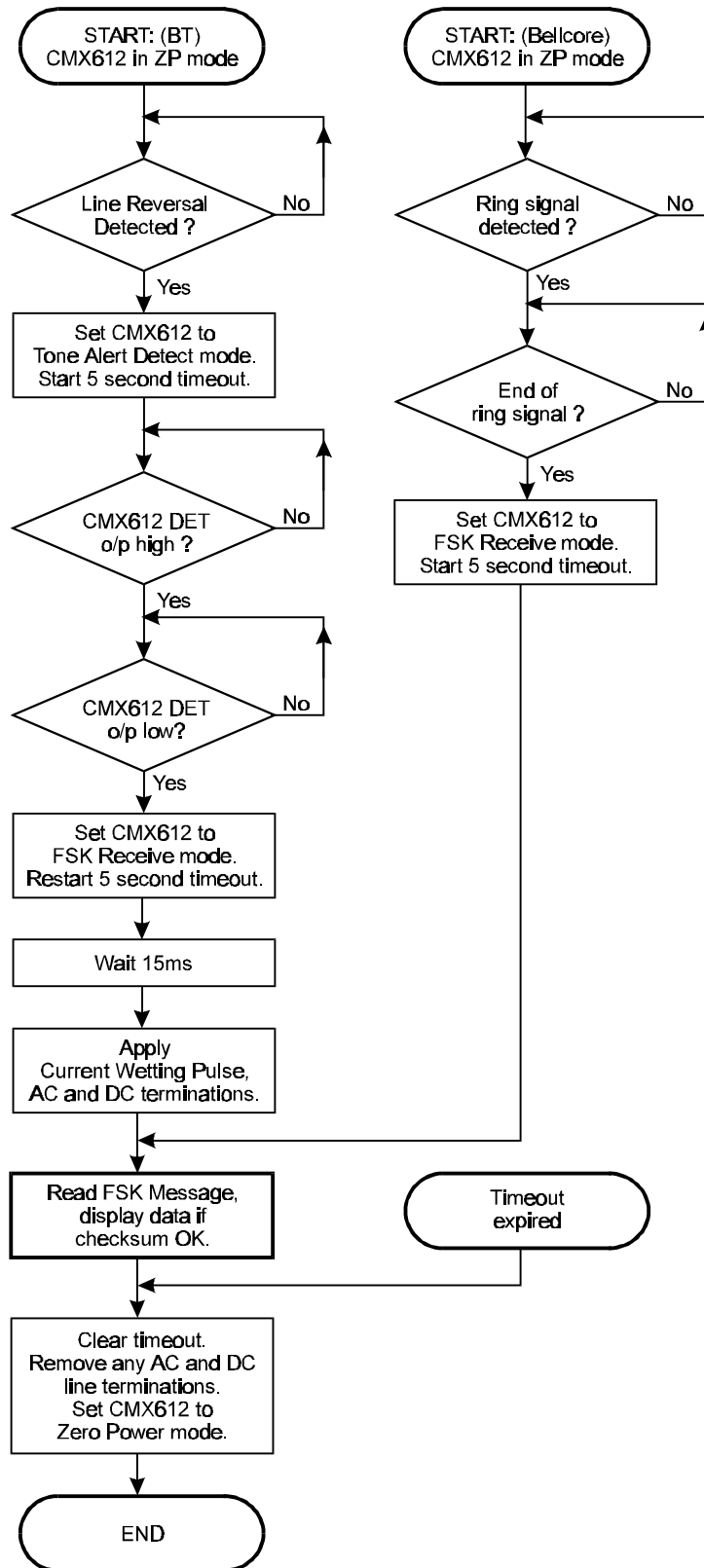

Figure 9c : Flow Chart for On-hook operation of CMX612



### 1.6.2 'Off-Hook' Operation

The CIDCW (Calling Identity on Call Waiting) system described in this section operates when the telephone set is in use (off-hook) to display the number of a waiting caller without interrupting the current call.

Bellcore documents GR-30-CORE and SR-TSV-002476, BT specifications SIN227 and SIN242 Part 2 and ETS 300-659-2 all describe similar systems in which a successful CIDCW transaction consists of a sequence of actions between the CPE (Customer Premises Equipment - e.g. a telephone) and the Central Office as indicated in Figure 10a.

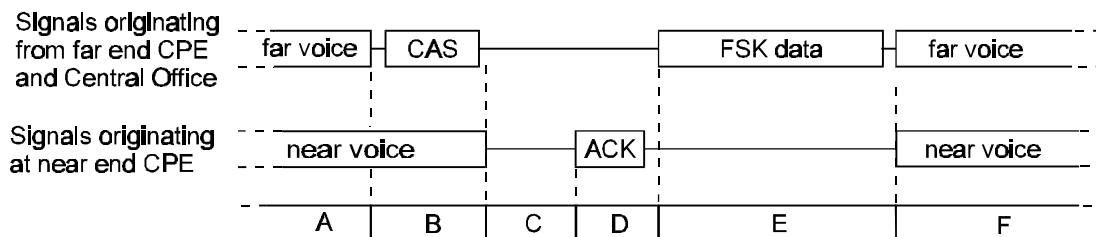

- A. Normal conversation with both near and far end voice present.
- B. Central Office mutes far end voice, sends CAS and becomes silent.
- C. CPE recognises CIDCW initiation and mutes near end voice and keypad.
- D. CPE sends dtmf ACK to Central Office to signal its readiness to receive FSK data.
- E. Central Office recognises ACK and sends FSK Caller ID data to CPE.
- F. CIDCW transaction is complete. CPE unmutes near end voice and the Central Office unmutes far end voice, returning to normal conversation.

**Figure 10a : CIDCW Transaction from Near End CPE Perspective**

The CAS signal is transmitted by the Central Office to initiate a CIDCW transaction and consists of an 80ms burst of simultaneous 2130Hz and 2750Hz tones.

CAS detection is very important because a “missed” signal causes Caller ID information to be lost and a false signal detection produces a disruptive tone which is heard by the far end caller. Because the CAS signals must be detected in the presence of conversations which both mask and masquerade as the tone signals, this function is difficult to accomplish correctly.

Because the numbers of false responses (Talk-offs) and missed signals (Talk-downs) are related to the speech levels at the CMX612 input, and because the level of near end speech from the local handset is normally greater than that of far end speech coming from the Central Office, a further improvement in overall performance can be obtained by taking the CMX612’s audio input from the receive side of the telephone set hybrid where this is possible.

The internal algorithms used by the CMX612 to drive the DET and IRQN outputs in Tone Alert Detect mode have been optimised for the detection of off-hook CAS signals in the presence of speech when used according to the following principles:

1. If it is possible to mute the local speech from the microphone rapidly (within 0.5ms) without introducing noise (i.e. where the CIDCW equipment is built into the telephone set) then this should be done whenever the CMX612 is in Tone Detect mode and the DET output is high. Doing this will markedly reduce the number of false responses generated by local (near end) speech. Note that the DET output is not used for any other purpose in an off-hook application when the CMX612 is set to Tone Alert Detect mode.

2. The IRQN output going low when in Tone Alert Detect mode indicates that a CAS has been detected. The local handset and keypad should then be muted as required by the Bellcore specification and the CMX612 switched to FSK Receive mode to be ready to receive the FSK data, doing this will also clear the IRQN output.
3. The CMX612's DET output should be monitored for a period of 50ms after changing to FSK Receive mode, before sending the ACK signal, and the transaction abandoned if the DET output goes high during this time, which would be the case if a false CAS detect had been caused by far end speech.

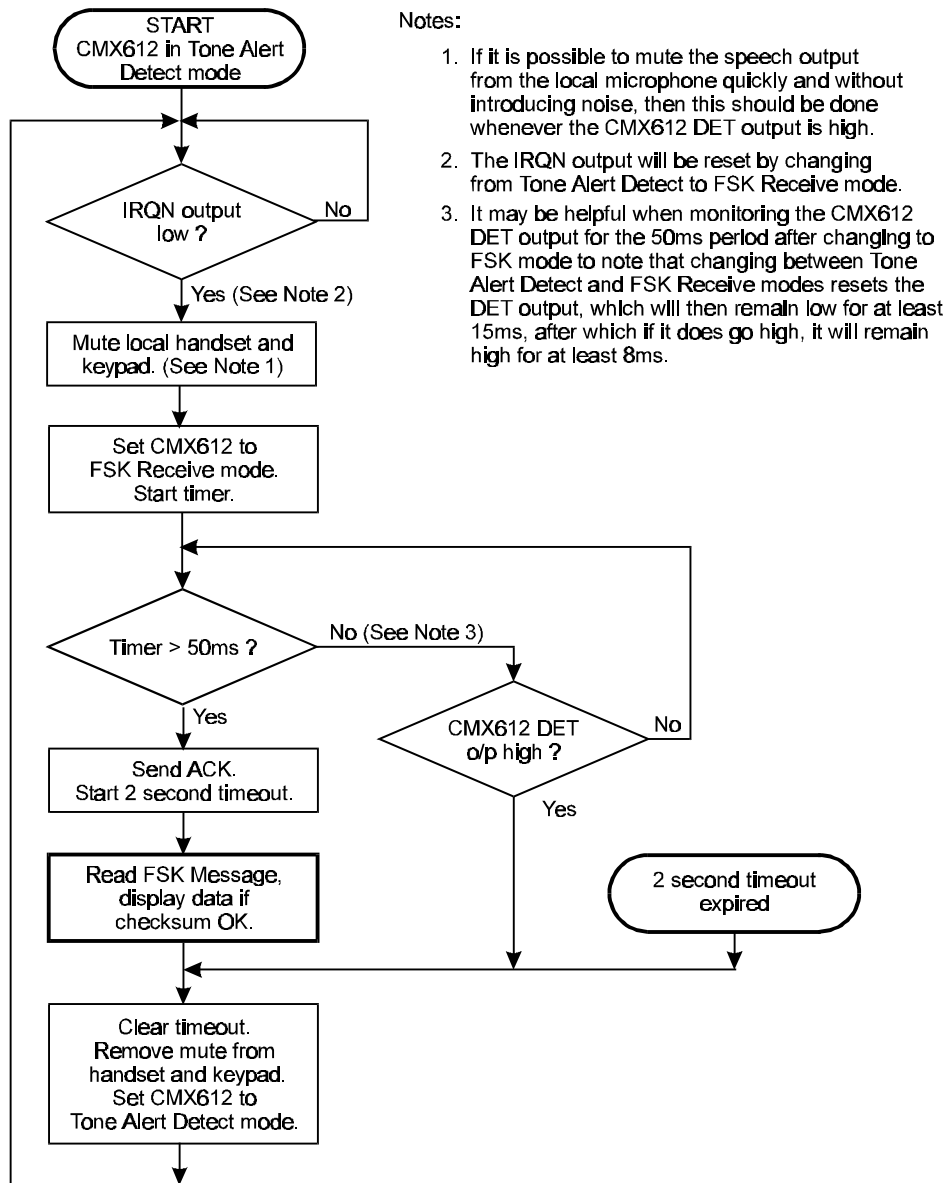

Figure 10b : Flow Chart for Off-hook operation of CMX612

### 1.6.3 VMWI Operation

VMWI is an indicator for a group of services that is offered by telephone companies to their customers. For example, it allows voice messages to be stored for later retrieval by the subscribing customer (Voice-Mail Notification). Messages may be entered into a mailbox by any of the following methods:

1. A call placed to the customer's line is unanswered after a certain number of rings and is then forwarded to the voice-mail system (forward on do not answer).
2. A call placed to the customer's line receives a busy signal and is then forwarded to the voice-mail system (forward on busy).
3. A message is forwarded to the customer's voice-mail box by a party directly through the voice-mail system, without the customer's line ever being called.

In each case, the presence of messages waiting in the customer's voice-mail box is indicated to the customer by generation of a VMWI signal. In Bellcore systems, the identification of a VMWI signal can be performed by detecting either a Stuttered Dial Tone (off-hook) or an FSK signal (on-hook).

### **SDT Mode**

When there is a message waiting in a customer's voice-mail box, the telephone company's Central Office (CO) switch may apply a special dial tone to the customer's line when it is taken off-hook. The special dial tone is called Stuttered Dial Tone and is generally characterised as follows:

1. Steady dial tone frequencies (350Hz + 440Hz).
2. Steady dial tone amplitude up to -12dBV per tone applied from the Central Office (CO) switch to the line.
3. A cadenced signal of 100ms on, 100ms off, repeated between 3 and 10 times and then steady dial tone.

According to the US-FCC Alameda order, the Customer Premises Equipment (CPE) will make a Stuttered Dial Tone check either:

1. When the subscriber takes the phone off-hook to make a call or
2. within 4 minutes of an unanswered call or
3. within 30 seconds of a completed call.

The telephone is taken off-hook to make a Stuttered Dial Tone check. The CPE then puts the CMX612 from 'Zero-Power' mode into Dial Tone Detect mode. If both dial tones are detected, then the DET output will be set high and the IRQN output will be set low.

The DET output may then be polled every 40 - 80ms to check if it has been cleared. The DET output will only be cleared if one or both tones are removed. If this occurs within 100ms, a counter may be incremented in the CPE (external to the CMX612) and the IRQN output should then be cleared. This may be done by taking the CMX612 out of Dial Tone Detect mode into 'Zero-Power' mode and back into Dial Tone Detect mode.

On receiving another interrupt, the polling routine described above should be repeated. If the counter reaches an appropriate value (e.g. 10) within an appropriate time (e.g. 2.3 seconds) then Stuttered Dial Tone has been detected and a visual message indicator will then be lit by the CPE.

Other algorithms to detect Stuttered Dial Tone (e.g. continuous polling of the DET output once an interrupt has been received) are also possible.

**CLASS (FSK) Mode**

When there is a message waiting in a customer's voice-mail box, the telephone company's Central Office (CO) switch may send on-hook FSK data to the customer's line. This can be received by the CMX612 and used to indicate waiting voice-mail (Voice-Mail Notification) and other CLASS services, by using the FSK Receive mode.

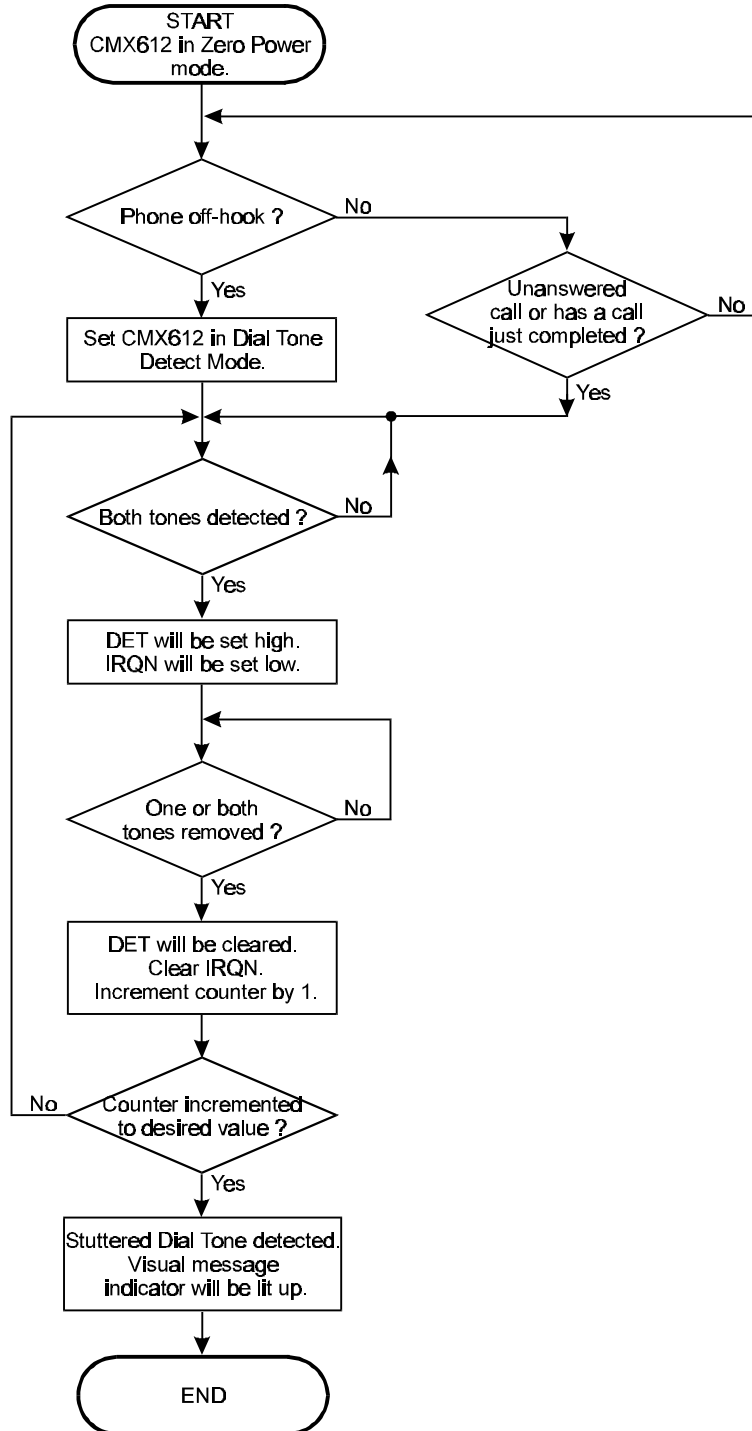

**Figure 11 : Flow Chart for VMWI-SDT operation of CMX612**

## 1.7 Performance Specification

### 1.7.1 Electrical Performance

#### 1.7.1.1 Absolute Maximum Ratings

Exceeding these maximum ratings can result in damage to the device.

	Min.	Max.	Units
Supply ( $V_{DD} - V_{SS}$ )	-0.3	7.0	V
Voltage on any pin to $V_{SS}$	-0.3	$V_{DD} + 0.3$	V
Current into or out of $V_{DD}$ and $V_{SS}$ pins	-30	+30	mA
Current into or out of any other pin	-20	+20	mA

<b>E3 Package</b>	Min.	Max.	Units
Total Allowable Power Dissipation at $T_{amb} = 25^{\circ}\text{C}$		300	mW
... Derating		5	mW/ $^{\circ}\text{C}$
Storage Temperature	-55	+125	$^{\circ}\text{C}$
Operating Temperature	-40	+85	$^{\circ}\text{C}$

<b>P6 Package</b>	Min.	Max.	Units
Total Allowable Power Dissipation at $T_{amb} = 25^{\circ}\text{C}$		800	mW
... Derating		13	mW/ $^{\circ}\text{C}$
Storage Temperature	-55	+125	$^{\circ}\text{C}$
Operating Temperature	-40	+85	$^{\circ}\text{C}$

#### 1.7.1.2 Operating Limits

Correct operation of the device outside these limits is not implied.

	Notes	Min.	Max.	Units
Supply ( $V_{DD} - V_{SS}$ )		2.7	5.5	V
Operating Temperature	2	-40	+85	$^{\circ}\text{C}$
Xtal Frequency	1	3.575965	3.583125	MHz

- Notes:**
1. An Xtal frequency of 3.579545MHz  $\pm$ 0.1% is required for correct Tone Alert and FSK detection.
  2. Operating temperature range  $-10^{\circ}\text{C}$  to  $+60^{\circ}\text{C}$  at  $V_{DD} < 3.0\text{V}$ .

### 1.7.1.3 Operating Characteristics

**Details in this section represent design target values and are not currently guaranteed.**

For the following conditions unless otherwise specified:

$V_{DD} = 2.7V$  at  $T_{amb} = -10$  to  $+60^{\circ}C$  and  $V_{DD} = 3.0V$  to  $5.5V$  at  $T_{amb} = -40^{\circ}C$  to  $+85^{\circ}C$ ,  
Xtal Frequency =  $3.579545MHz \pm 0.1\%$ , 0dBV corresponds to 1.0Vrms.

	Notes	Min.	Typ.	Max.	Units
<b>DC Parameters</b>					
$I_{DD}$ (in 'Zero-Power' mode) at $V_{DD} = 5.0V$	1, 2		0.02	TBD	$\mu A$
$I_{DD}$ (not in 'Zero-Power' mode) at $V_{DD} = 3.0V$	1		0.5	TBD	mA
$I_{DD}$ (not in 'Zero-Power' mode) at $V_{DD} = 5.0V$	1		1.0	TBD	mA
Logic '1' input level (RXCK and XTAL inputs)		70%			$V_{DD}$
Logic '0' input level (RXCK and XTAL inputs)				30%	$V_{DD}$
Logic input leakage current ( $V_{in} = 0$ to $V_{DD}$ ) excluding XTAL input		-1.0		+1.0	$\mu A$
Output logic '1' level ( $I_{OH} = 360\mu A$ )		$V_{DD} - 0.4V$			V
Output logic '0' level ( $I_{OL} = 360\mu A$ )				0.4	V
IRQN o/p 'off' state current ( $V_{out} = V_{DD}$ )				1.0	$\mu A$
<b>Schmitt Trigger input thresholds, see Fig 12</b>					
High going ( $V_{thi}$ )		$0.56V_{DD}$		$0.56V_{DD} + 0.6V$	V
Low going ( $V_{tlo}$ )		$0.44V_{DD} - 0.6V$		$0.44V_{DD}$	V
<b>Tone Alert Detector</b>					
'Low' tone nominal frequency			2130		Hz
'High' tone nominal frequency			2750		Hz
Start of Tone Alert signal to DET high time (Fig 6 Tton)			55.0		ms
End of Tone Alert signal to DET and IRQN low time (Fig 6 Ttoff)		0.5		10.0	ms
DET high time to ensure IRQN goes low (Fig 6 TqCAS)		8.0		45.0	ms
<b>To ensure detection:</b>					
'Low' tone frequency tolerance	3			$\pm 0.5$	%
'High' tone frequency tolerance				$\pm 0.5$	%
Level (total) 2750Hz tone level wrt 2130Hz tone level	4	-40.0		-2.2	dBV
Signal to Noise ratio	5	20.0		+6.0	dB
Dual tone burst duration for DET output		75.0			ms
Dual tone burst duration to ensure IRQN goes low		75.0		85.0	ms
<b>To ensure non-detection:</b>					
'Low' tone frequency tolerance	6	$\pm 75.0$			Hz
'High' tone frequency tolerance		$\pm 95.0$			Hz
Level (total)	4			-46.0	dBV
Dual tone burst duration				45.0	ms

	Notes	Min.	Typ.	Max.	Units
<b>FSK Receiver</b>					
Transmission rate		1188	1200	1212	Baud
V23 Mark (logical 1) frequency		1280	1300	1320	Hz
V23 Space (logical 0) frequency		2068	2100	2132	Hz
Bell202 Mark (logical 1) frequency		1188	1200	1212	Hz
Bell202 Space (logical 0) frequency		2178	2200	2222	Hz
Valid input level range	4	-40.0		-8.0	dBV
Acceptable twist (mark level wrt space level)					
V23		-6.0		+6.0	dB
Bell202		-10.0		+10.0	dB
Acceptable Signal to Noise ratio					
V23	5	20.0			dB
Bell202	5	30.0			dB
Level Detector 'on' threshold level	4			-40.0	dBV
Level Detector 'off' to 'on' time (Fig 4 Teon)				25.0	ms
Level Detector 'on' to 'off' time (Fig 4 Teoff)		8.0			ms
<b>Input Signal Amplifier</b>					
Input impedance	7	10.0			M $\Omega$
Voltage gain			500		V/V
<b>XTAL Input</b>					
'High' pulse width	8	100			ns
'Low' pulse width	8	100			ns
<b>Dial Tone Detector</b>					
'Low' tone nominal frequency			350		Hz
'High' tone nominal frequency			440		Hz
Start of Dial Tone signal to DET high time (Fig 7 Tdon)			60.0		ms
End of Dial Tone signal to DET and IRQN low time (Fig 7 Tdoff)		3.0		30.0	ms
DET high time (100ms tone duration)		1.3	40.0	60.0	ms
<b>To ensure detection:</b>	3				
'Low' tone frequency tolerance				$\pm 7.0$	Hz
'High' tone frequency tolerance				$\pm 7.0$	Hz
Level (per tone)	4	-31.2		-12.2	dBV
350Hz tone level wrt 440Hz tone level		-6.0		+6.0	dB
Signal to Noise ratio	5	20.0			dB
Dual tone burst duration for DET output	9	80.0			ms
Dual tone burst duration to ensure IRQN goes low	9	80.0			ms
<b>To ensure non-detection:</b>	6				
'Low' tone frequency tolerance		-45.0		+30.0	Hz
'High' tone frequency tolerance		-30.0		+40.0	Hz
Level (total)	4			-36.0	dBV
Dual tone burst duration				30.0	ms

- Notes:**
1. At 25°C, not including any current drawn from the CMX612 pins by external circuitry other than X1, C1 and C2.
  2. RD, RXCK, MODE 2 inputs at  $V_{SS}$ , MODE 1 input at  $V_{DD}$ . See also Figure 13.
  3. All conditions must be met to ensure detection.
  4. For  $V_{DD} = 3.3V$  with equal level tones and with the input signal amplifier external components as Section 1.4. The internal threshold levels are proportional to  $V_{DD}$ . To cater for other supply voltages or different signal level ranges the voltage gain of the input signal amplifier should be adjusted by selecting the appropriate external components as described in Section 1.5
  5. Flat noise in 300 - 3400Hz band for V23, 200 - 3200Hz for Bell202.
  6. Meeting any of these conditions will ensure non-detection.
  7. Open loop, small signal low frequency measurements.
  8. Timing for an external input to the CLOCK/XTAL pin.
  9. Tone duration between 80ms and 90ms will normally give 100% detection. However, under certain conditions (e.g. exact 4:5 ratio between tone frequencies and adverse twist conditions) up to 0.3% of tones may not be detected. Above 90ms, detection is 100%.



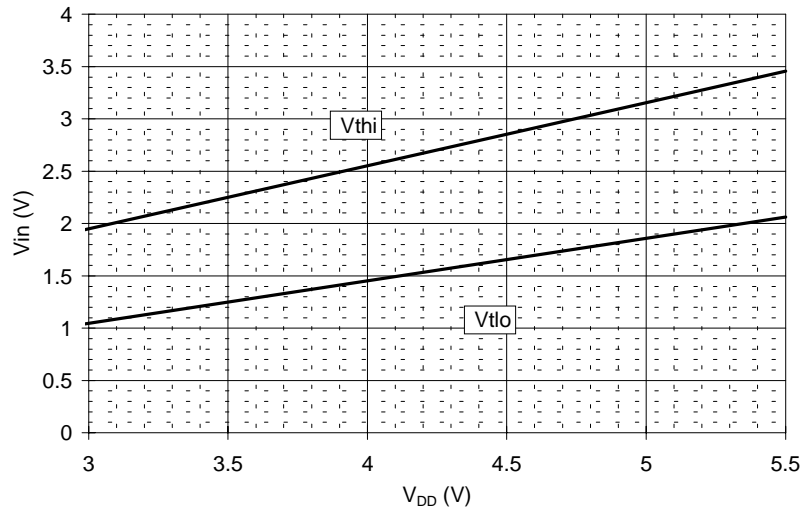

Figure 12 : Schmitt Trigger typical input voltage thresholds vs.  $V_{DD}$

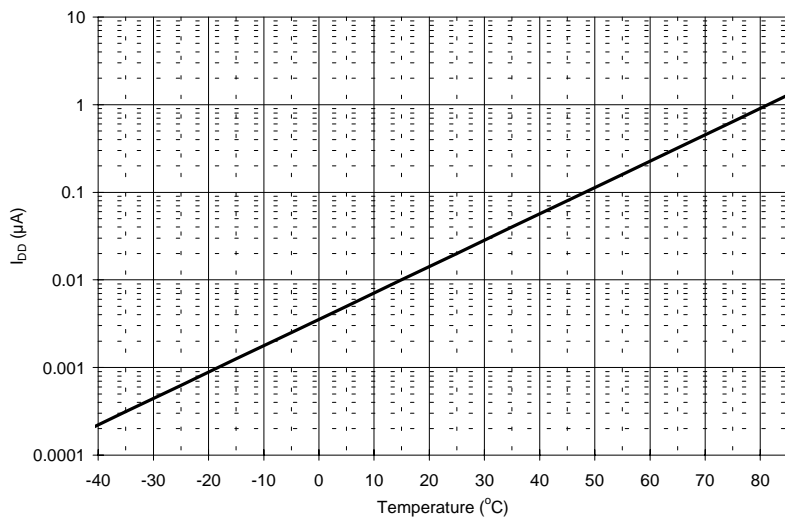
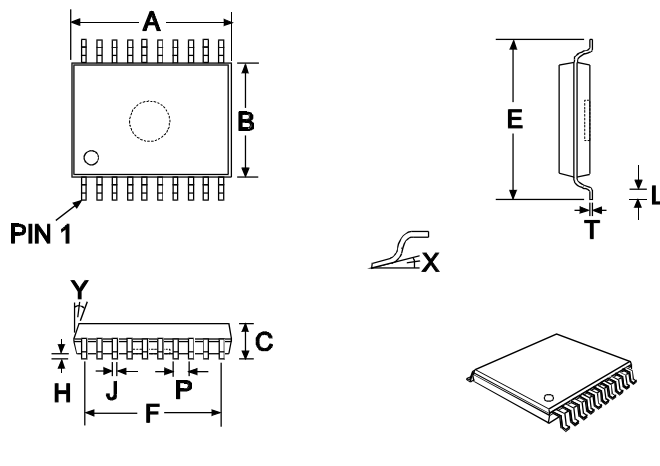

Figure 13 : Typical 'Zero Power'  $I_{DD}$  vs. Temperature ( $V_{DD} = 5.0V$ )

1.7.2 Packaging



DIM.	MIN.	TYP.	MAX.
* A	0.252 (6.40)		0.260 (6.60)
* B	0.169 (4.30)		0.177 (4.50)
C			0.047 (1.20)
E	0.248 (6.30)		0.256 (6.50)
F		0.230 (5.85)	
H	0.002 (0.05)		0.006 (0.15)
J	0.007 (0.17)		0.012 (0.30)
L	0.020 (0.50)		0.030 (0.75)
P		0.026 (0.65)	
T	0.003 (0.08)		0.008 (0.20)
X		0°	7°
Y		12°	

NOTE :

\* A & B are reference data and do not include mold deflash or protrusions.

All dimensions in inches (mm.)  
Angles are in degrees

Figure 14 : 20-pin TSSOP (E3) Mechanical Outline: Order as part no. CMX612E3

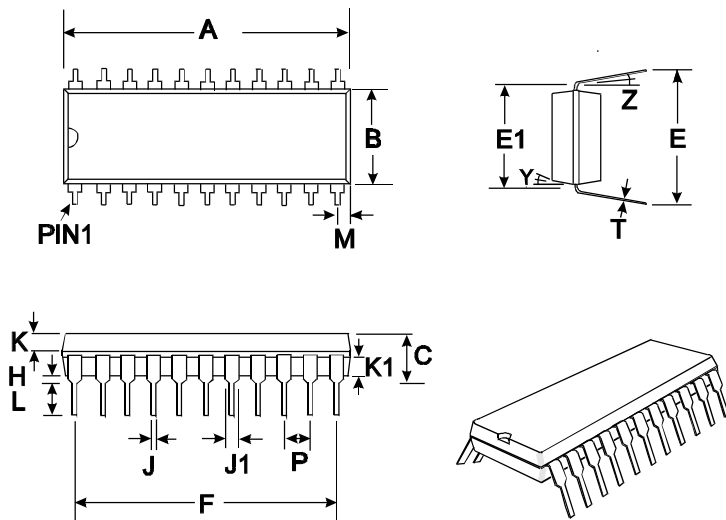

DIM.	MIN.	TYP.	MAX.
* A	1.080 (27.43)		1.10 (27.94)
* B	0.330 (8.38)		0.360 (9.14)
C	0.170 (4.32)		0.195 (4.95)
E	0.420 (10.67)		0.480 (12.19)
E1	0.390 (9.90)		0.420 (10.67)
F		1.0 (25.40)	
H	0.020 (0.51)		0.045 (1.14)
J	0.015 (0.38)		0.020 (0.51)
J1	0.040 (1.02)		0.065 (1.65)
K	0.066 (1.68)		0.074 (1.88)
K1	0.060 (1.52)		0.074 (1.88)
L	0.121 (3.07)		0.160 (4.06)
M		0.045 (1.14)	
P		0.100 (2.54)	
T	0.008 (0.20)		0.015 (0.38)
Y		7°	
Z		4°	

NOTE :

\* A & B are reference datum's and do not include mold deflash or protrusions.

All dimensions in inches (mm.)  
Angles are in degrees

Figure 15 : 22-pin DIL (P6) Mechanical Outline: Order as part no. CMX612P6

Handling precautions: This product includes input protection, however, precautions should be taken to prevent device damage from electro-static discharge. CML does not assume any responsibility for the use of any circuitry described. No IPR or circuit patent licences are implied. CML reserves the right at any time without notice to change the said circuitry and this product specification. CML has a policy of testing every product shipped using calibrated test equipment to ensure compliance with this product specification. Specific testing of all circuit parameters is not necessarily performed.



**Consumer  
Microcircuits  
Limited**  
*COMMUNICATION SEMICONDUCTORS*

**Oval Park - LANGFORD  
MALDON - ESSEX  
CM9 6WG - ENGLAND**

**Telephone: +44 (0)1621 875500  
Telefax: +44 (0)1621 875600  
e-mail: [sales@cmlmicro.co.uk](mailto:sales@cmlmicro.co.uk)  
<http://www.cmlmicro.co.uk>**

**k**

