

FEATURES

- RoHS compliant
- Efficiency to 79%
- Power density up to 0.85W/cm³
- Wide temperature performance at full 1 Watt load, -40°C to 85°C
- Single or dual output
- UL 60950 recognized for functional insulation
- UL 94V-0 package material
- No heatsink required
- Footprint from 1.17cm²
- Industry standard pinout
- Power sharing on dual output
- 3kVDC isolation (1 minute) 'Hi-Pot Test'
- 5V, 12V, & 15V input
- 5V, 9V, 12V and 15V output
- Internal SMD construction
- Fully encapsulated with toroidal magnetics
- No external components required
- MTTF up to 4.2 million hours
- No electrolytic or tantalum capacitors

PRODUCT OVERVIEW

The NMV series of industrial temperature range DC/DC converters are the standard building blocks for on-board distributed power systems. They are ideally suited for providing local supplies on control system boards with the added benefit of 3kVDC galvanic isolation to reduce switching noise. Available in SIP and DIP with dual and single output pinout. All of the rated power may be drawn from a single pin provided the total load does not exceed 1 watt.



For full details go to www.murata-ps.com/rohs



SELECTION GUIDE

Order Code	Nominal Input Voltage	Output Voltage	Output Current	Input Current at Rated Load	Load Regulation (Typ)	Load Regulation (Max)	Ripple & Noise (Typ)	Ripple & Noise (Max)	Efficiency	Isolation Capacitance	MTTF ¹	Package Style
	V	V	mA	mA	%	%	mVp-p	mVp-p	%	pF	kHrs	
NMV0505DAC	5	5	200	294	14.6	15	15	17	68	23	4241	DIP
NMV0509DAC	5	9	111	267	9.3	10	11.3	15	75	30	3376	
NMV0512DAC	5	12	84	260	7.4	8.0	10.5	16	77	26	2555	
NMV0515DAC	5	15	67	256	6.7	7.3	8.7	11	78	27	1838	SIP
NMV0505SAC	5	5	200	294	14.6	15	16	23	68	23	4241	
NMV0509SAC	5	9	111	267	9.3	10	12	15	75	30	3376	
NMV0512SAC	5	12	84	260	7.4	8.0	11	15	77	26	2555	DIP
NMV0515SAC	5	15	67	256	6.7	7.3	11	14	78	27	1838	
NMV1205DAC	12	5	200	121	14.6	15	9.5	14	69	26	2664	
NMV1209DAC	12	9	111	113	9.3	10	7	8.5	74	35	2295	DIP
NMV1212DAC	12	12	84	108	7.4	8.0	8	19	77	43	1883	
NMV1215DAC	12	15	67	108	6.7	7.3	8	17	77	42	1462	
NMV1205SAC	12	5	200	121	14.6	15	11	16	69	26	2664	SIP
NMV1209SAC	12	9	111	113	9.3	10	7.5	14	74	35	2295	
NMV1212SAC	12	12	84	108	7.4	8.0	9	22	77	43	1883	
NMV1215SAC	12	15	67	108	6.7	7.3	8.5	17	77	42	1462	SIP
NMV1505SAC	15	5	200	93	8.3	10	15.5	17	67	21	2747	
NMV1512SAC	15	12	84	85	3.3	4.0	11.2	14	75	45	1365	
NMV1515SAC	15	15	67	84	2.8	4.0	11	13	77	50	941	DIP
NMV0505DC	5	±5	±100	280	9.0	10	11	14	71.5	21	3106	
NMV0509DC	5	±9	±55	263	7.5	8.5	7.5	9	76	24	2258	
NMV0512DC	5	±12	±42	256	6.8	7.5	6.7	9	78	26	1579	SIP
NMV0515DC	5	±15	±33	253	6.8	8.5	6	9	79	27	1065	
NMV0505SC	5	±5	±100	280	9.0	10	11	17	71.5	21	3106	
NMV0509SC	5	±9	±55	263	7.5	8.5	7	9.4	76	24	2258	SIP
NMV0512SC	5	±12	±42	256	6.8	7.5	6.7	8	78	26	1579	
NMV0515SC	5	±15	±33	253	6.8	8.5	6.3	8.2	79	27	1065	
NMV1205DC	12	±5	±100	117	9.0	10	8.6	12	71	27	2148	DIP
NMV1209DC	12	±9	±55	113	7.5	8.5	6.5	9	74	35	1705	
NMV1212DC	12	±12	±42	111	6.8	7.5	6.2	8.5	75	42	1287	
NMV1215DC	12	±15	±33	110	6.8	8.5	5.5	8	76	41	924	SIP
NMV1205SC	12	±5	±100	117	9.0	10	10	13	71	27	2148	
NMV1209SC	12	±9	±55	113	7.5	8.5	8	11	74	35	1705	
NMV1212SC	12	±12	±42	111	6.8	7.5	6	10	75	42	1287	SIP
NMV1215SC	12	±15	±33	110	6.8	8.5	6.5	13	76	41	924	
NMV1505SC	15	±5	±100	91	5.5	10	11	12	69	39	1941	
NMV1512SC	15	±12	±42	87	2.6	3.0	7.5	9	75	68	789	SIP
NMV1515SC	15	±15	±33	84	2.3	3.0	7.5	9	77	84	522	

INPUT CHARACTERISTICS

Parameter	Conditions	Min.	Typ.	Max.	Units
Voltage range	Continuous operation, 5V input types	4.5	5	5.5	V
	Continuous operation, 12V input types	10.8	12	13.2	
	Continuous operation, 15V input types	13.5	15	16.5	
Reflected ripple current			20	40	mA p-p

1. Calculated using MIL-HDBK-217F with nominal input voltage at full load.

All specifications typical at T_A=25°C, nominal input voltage and rated output current unless otherwise specified.

ABSOLUTE MAXIMUM RATINGS

Lead temperature 1.5mm from case for 10 seconds	300°C
Internal power dissipation	560mW
Input voltage V_{IN} , NMV05 types	7V
Input voltage V_{IN} , NMV12 types	15V
Input voltage V_{IN} , NMV15 types	18V

OUTPUT CHARACTERISTICS

Parameter	Conditions	Min.	Typ.	Max.	Units
Rated Power ²	$T_A = -40^\circ\text{C}$ to 120°C			1	W
Voltage Set Point Accuracy	See tolerance envelope				
Line regulation	High V_{IN} to low V_{IN}		1.0	1.2	%/%

ISOLATION CHARACTERISTICS

Parameter	Conditions	Min.	Typ.	Max.	Units
Isolation test voltage	Flash tested for 1 minute	3000			VDC
Resistance	Viso= 1000VDC	10			GΩ

GENERAL CHARACTERISTICS

Parameter	Conditions	Min.	Typ.	Max.	Units
Switching frequency	5V input types		120	135	kHz
	12V input types		150	170	
	15V input types		90	110	

TEMPERATURE CHARACTERISTICS

Parameter	Conditions	Min.	Typ.	Max.	Units
Specification	All output types	-40		85	°C
Storage		-50		125	
Case Temperature above ambient	5V output types			28	
	All other output types			25	
Cooling	Free air convection				

TEMPERATURE DERATING GRAPH

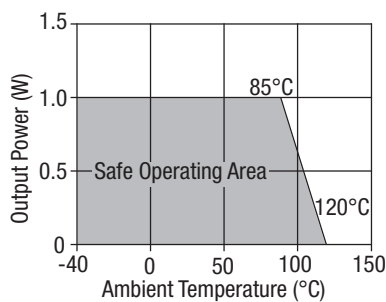

TOLERANCE ENVELOPE

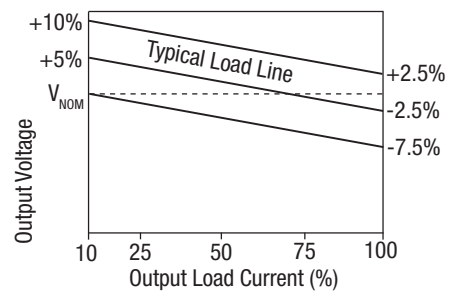

The voltage tolerance envelope shows typical load regulation characteristics for this product series. The tolerance envelope is the maximum output voltage variation due to changes in output loading.

RoHS COMPLIANCE INFORMATION



This series is compatible with RoHS soldering systems with a peak wave solder temperature of 300°C for 10 seconds. The pin termination finish on the SIP package type is Tin Plate, Hot Dipped over Matte Tin with Nickel Preplate. The DIP types are Matte Tin over Nickel Preplate. Both types in this series are backward compatible with Sn/Pb soldering systems.

For further information, please visit www.murata-ps.com/rohs

TECHNICAL NOTES

ISOLATION VOLTAGE

'Hi Pot Test', 'Flash Tested', 'Withstand Voltage', 'Proof Voltage', 'Dielectric Withstand Voltage' & 'Isolation Test Voltage' are all terms that relate to the same thing, a test voltage, applied for a specified time, across a component designed to provide electrical isolation, to verify the integrity of that isolation.

Murata Power Solutions NMV series of DC/DC converters are all 100% production tested at their stated isolation voltage. This is 3kVDC for 1 minute.

A question commonly asked is, "What is the continuous voltage that can be applied across the part in normal operation?"

The NMV has been recognized by Underwriters Laboratory for functional insulation, both input and output should normally be maintained within SELV limits i.e. less than 42.4V peak, or 60VDC. The isolation test voltage represents a measure of immunity to transient voltages and the part should never be used as an element of a safety isolation system. The part could be expected to function correctly with several hundred volts offset applied continuously across the isolation barrier; but then the circuitry on both sides of the barrier must be regarded as operating at an unsafe voltage and further isolation/insulation systems must form a barrier between these circuits and any user-accessible circuitry according to safety standard requirements.

REPEATED HIGH-VOLTAGE ISOLATION TESTING

It is well known that repeated high-voltage isolation testing of a barrier component can actually degrade isolation capability, to a lesser or greater degree depending on materials, construction and environment. The NMV series has toroidal isolation transformers, with no additional insulation between primary and secondary windings of enameled wire. While parts can be expected to withstand several times the stated test voltage, the isolation capability does depend on the wire insulation. Any material, including this enamel (typically polyurethane) is susceptible to eventual chemical degradation when subject to very high applied voltages thus implying that the number of tests should be strictly limited. We therefore strongly advise against repeated high voltage isolation testing, but if it is absolutely required, that the voltage be reduced by 20% from specified test voltage.

This consideration equally applies to agency recognized parts rated for better than functional isolation where the wire enamel insulation is always supplemented by a further insulation system of physical spacing or barriers.

SAFETY APPROVAL

The NMV series has been recognized by Underwriters Laboratory (UL) to UL 60950 for functional insulation.

The NMV Series of converters are not internally fused so to meet the requirements of UL 60950 an anti-surge input line fuse should always be used with ratings as defined below.

NMV05xxxC: 0.315A

NMV12xxxC: 1A

NMV15xxxC: 1A

All fuses should be UL recognized and rated to at least the maximum allowable DC input voltage.

File number E151252 applies.

APPLICATION NOTES

Minimum load

The minimum load to meet datasheet specification is 10% of the full rated load across the specified input voltage range. Lower than 10% minimum loading will result in an increase in output voltage, which may rise to typically double the specified output voltage if the output load falls to less than 5%.

Capacitive loading and start up

Typical start up times for this series, with a typical input voltage rise time of 2.2µs and output capacitance of 10µF, are shown in the table below. The product series will start into a capacitance of 47µF with an increased start time, however, the maximum recommended output capacitance is 10µF.

	Start-up time µs		Start-up time µs
NMV0505xC	1966	NMV1212xC	8650
NMV0509xC	5360	NMV1215xC	11171
NMV0512xC	11180	NMV1505xC	803
NMV0515xC	16270	NMV1512xC	3510
NMV1205xC	1290	NMV1515xC	8361
NMV1209xC	4140		

Typical Start-Up Wave Form

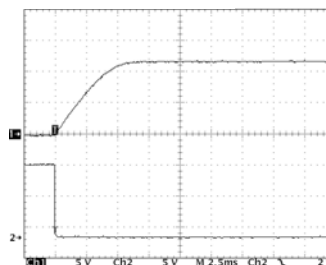

APPLICATION NOTES (continued)

Ripple & Noise Characterisation Method

Ripple and noise measurements are performed with the following test configuration.

C1	1µF X7R multilayer ceramic capacitor, voltage rating to be a minimum of 3 times the output voltage of the DC/DC converter
C2	10µF tantalum capacitor, voltage rating to be a minimum of 1.5 times the output voltage of the DC/DC converter with an ESR of less than 100mΩ at 100 kHz
C3	100nF multilayer ceramic capacitor, general purpose
R1	450Ω resistor, carbon film, ±1% tolerance
R2	50Ω BNC termination
T1	3T of the coax cable through a ferrite toroid
RLOAD	Resistive load to the maximum power rating of the DC/DC converter. Connections should be made via twisted wires

Measured values are multiplied by 10 to obtain the specified values.

Differential Mode Noise Test Schematic

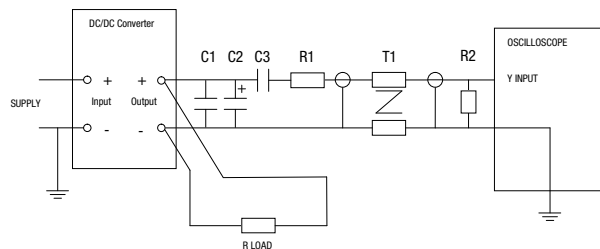

Output Ripple Reduction

By using the values of inductance and capacitance stated, the output ripple at the rated load is lowered to 5mV p-p max.

Component selection

Capacitor: It is required that the ESR (Equivalent Series Resistance) should be as low as possible, ceramic types are recommended. The voltage rating should be at least twice (except for 15V output), the rated output voltage of the DC/DC converter.

Inductor: The rated current of the inductor should not be less than that of the output of the DC/DC converter. At the rated current, the DC resistance of the inductor should be such that the voltage drop across the inductor is <2% of the rated voltage of the DC/DC converter. The SRF (Self Resonant Frequency) should be >20MHz.

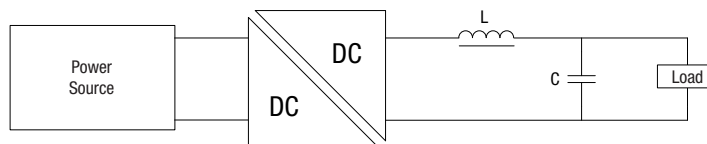

	Inductor			Capacitor
	L, µH	SMD	Through Hole	C, µF
NMV0505xC	22	82223C	11R223C	1
NMV0509xC	100	82104C	11R104C	0.47
NMV0512xC	150	82154C	11R154C	0.33
NMV0515xC	220	82224C	11R224C	0.22
NMV1205xC	22	82223C	11R223C	2.2
NMV1209xC	100	82104C	11R104C	1
NMV1212xC	150	82154C	11R154C	0.33
NMV1215xC	220	82224C	11R224C	0.22
NMV1505xC	22	82223C	11R223C	1
NMV1512xC	150	82154C	11R154C	0.33
NMV1515xC	220	82224C	11R224C	0.22

PACKAGE SPECIFICATIONS

MECHANICAL DIMENSIONS

DIP package

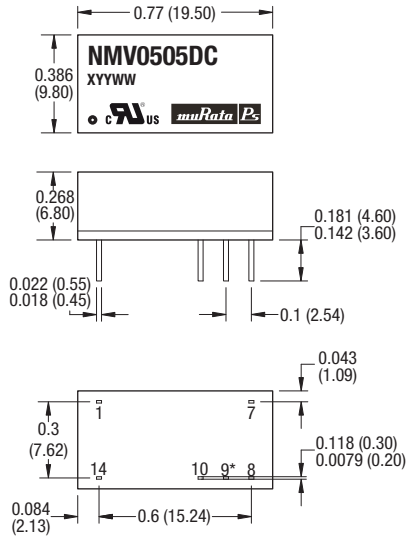

SIP package

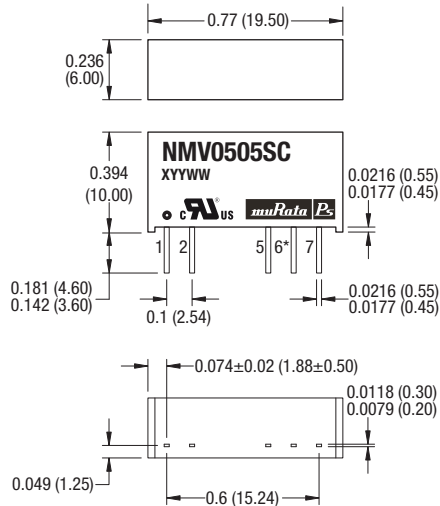

* Pin not fitted on single output variants.

All dimensions in inches ± 0.01 (mm ± 0.25 mm). All pins on a 0.1 (2.54) pitch and within ± 0.01 (0.25) of true position.

Weight: 2.4g (DIP) 2.1g (SIP)

PIN CONNECTIONS

Single output variants

14 Pin DIP		7 Pin SIP	
Pin	Function	Pin	Function
1	-VIN	1	+VIN
7	NC	2	-VIN
8	+VOUT	5	-VOUT
10	-VOUT	7	+VOUT
14	+VIN		

Dual output variants

14 Pin DIP		7 Pin SIP	
Pin	Function	Pin	Function
1	-VIN	1	+VIN
7	NC	2	-VIN
8	+VOUT	5	-VOUT
9	OV	6	OV
10	-VOUT	7	+VOUT
14	+VIN		

PACKAGE SPECIFICATIONS (continued)

RECOMMENDED FOOTPRINT DETAILS

14 Pin DIP Package

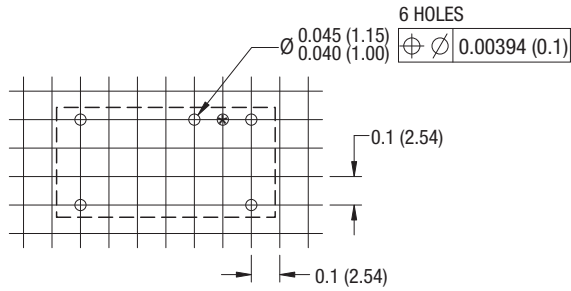

7 Pin SIP Package

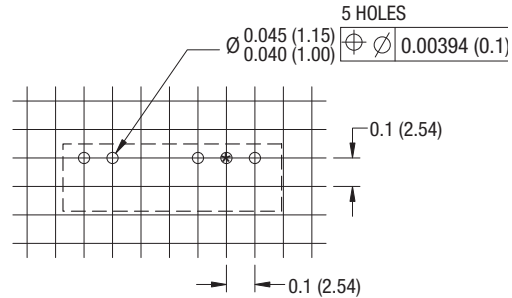

*Hole not required for single output variants.

TUBE OUTLINE DIMENSIONS

14 Pin DIP Tube

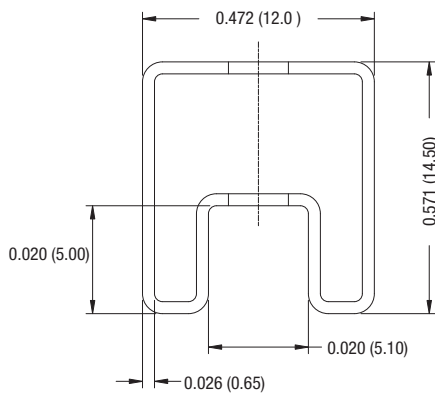

7 Pin SIP Tube

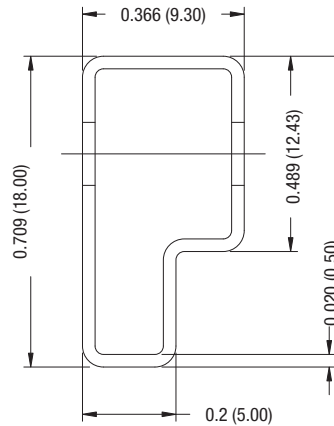

Unless otherwise stated all dimensions in inches (mm) ± 0.5 mm.
 Tube length (14 Pin DIP) : 20.47 (520mm ± 2 mm).
 Tube length (7 Pin SIP) : 20.47 (520mm ± 2 mm).

Tube Quantity : 25

Murata Power Solutions, Inc.
 11 Cabot Boulevard, Mansfield, MA 02048-1151 U.S.A.
 ISO 9001 and 14001 REGISTERED



This product is subject to the following **operating requirements** and the **Life and Safety Critical Application Sales Policy**:
 Refer to: <http://www.murata-ps.com/requirements/>

Murata Power Solutions, Inc. makes no representation that the use of its products in the circuits described herein, or the use of other technical information contained herein, will not infringe upon existing or future patent rights. The descriptions contained herein do not imply the granting of licenses to make, use, or sell equipment constructed in accordance therewith. Specifications are subject to change without notice.
 © 2015 Murata Power Solutions, Inc.