



4-Channel High Constant Current Driver

Product Description

The SCT2004 is a four channels constant current driver best for LED lighting. It provides the PWM control effect by sinking constant current from LED clusters with minimum pulse width 80ns. The PWM control is performed by connecting the PWM signal from system control unit to OE pin of the SCT2004. The full scale current value of each output is set by an external resistor connected to REXT pin.

The SCT2004 guarantees to endure maximum DC 24V at each output port. Each output of SCT2004 can sink a constant current up to 320mA. Users can simply shunt the outputs to get higher current driver-ability, especially in the case of high power LED lighting.

The excellent current regulation capability allows SCT2004 easily drive each output current to a constant stable output nearly without affected by power supply of LED, loading due to variant V_F of LEDs and operating temperature. The SCT2004 is equipped with negative temperature coefficient characteristics, thus the driver system and LEDs are protected from damage of thermal runaway or overheated.

Features

- ◆ Four constant-current outputs rate at 24V
- ◆ Constant current range: 20 – 320mA
- ◆ Excellent regulation to load, supply voltage and temperature
- ◆ Minimum PWM pulse width 80ns
- ◆ $\pm 2\%$ (typ) current matching between outputs
- ◆ $\pm 4\%$ (typ) current matching between ICs
- ◆ Dropout output 0.4V@80mA, $V_{DD}=5V$
- ◆ All output current are adjusted through one external resistor
- ◆ Built-in power on reset and thermal protection
- ◆ Supply voltage range 4 to 5V
- ◆ Dimming control with Schmitt triggered input
- ◆ Package: SOP8 with heat sink pad
- ◆ Application: LED backlight, LED lighting, LED lamp

Pin Configuration



Terminal Description

Pin Name	Pin No.	I/O	Function
GND	1	-	Ground terminal
OE	2	I	Input terminal of output enable signal. Output is enabled when OE is high.
OUT1~4	3~6	O	Output terminals with constant current
REXT	7	I/O	Input terminal connected to an external resistor for setting up all output current
VDD	8	-	Supply voltage terminal
TP	-	-	Thermal pad, please connect TP to ground.

Block Diagram

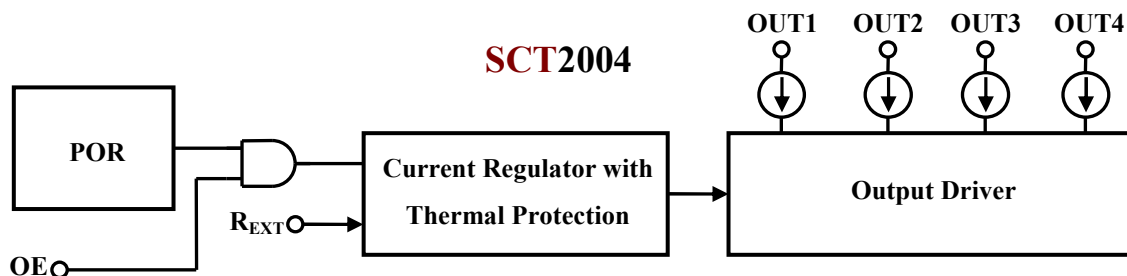

Equivalent Circuits of Inputs

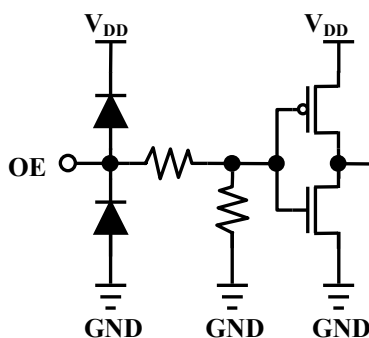

Ordering information

Part	Marking	Package	Unit per reel(pcs)
SCT2004CSOG	SCT2004CSOG	Green SOP8(150mil) with thermal pad	2500

StarChips Technology, Inc.

4F, No.5, Technology Rd., Science-Based Industrial Park, Hsin-Chu, Taiwan, R.O.C.

Tel : +886-3-577-5767 Ext.555

Fax: +886-3-577-6575

E-mail : service@starchips.com.tw

Maximum Ratings ($T_A = 25^\circ\text{C}$)

Characteristic	Symbol	Rating	Unit
Supply voltage	V_{DD}	7	V
Input voltage	V_{IN}	-0.2 ~ $V_{DD}+0.2$	V
Output current	I_{OUT}	360	mA/Channel
Output voltage	V_{OUT}	24	V
Total GND terminals current	I_{GND}	1200	mA
Power dissipation	SOP8TP P_D	2.08	W
Thermal resistance	SOP8TP $R_{TH(j-a)}$	60	$^\circ\text{C}/\text{W}$
Operating temperature	T_{OPR}	-40~+85	$^\circ\text{C}$
Storage temperature	T_{STG}	-55~+150	$^\circ\text{C}$

The absolute maximum ratings are a set of ratings not to be exceeded. Stresses beyond those listed under "Maximum Ratings" may cause the device breakdown, deterioration even permanent damage. Exposure to the maximum rating conditions for extended periods may affect device reliability.

Recommended Operating Conditions ($T_A = -40$ to 85°C unless otherwise noted)

Characteristic	Symbol	Conditions	Min.	Typ.	Max.	Unit
Supply voltage	V_{DD}	-	4.5	-	5.5	V
Output voltage	V_{OUT}	Output OFF	-	-	24	V
		Output ON	-	1 ¹	4 ²	V
Output current	I_{OUT}	$V_{DD}=5\text{V}$	20	-	320	mA
Input voltage	V_{IH}	-	2	-	V_{DD}	V
	V_{IL}	-	0	-	0.4	V
OE pulse width	t_w	$V_{DD}=5\text{V}$	80	-	-	ns

- The output current keep constant in range of 20-320mA if $V_{OUT}=1\text{V}$.
However, user can minimize V_{OUT} to reduce power dissipation according to used current, e.g., set V_{OUT} to 0.4V if $I_{OUT}=80\text{mA}$.
- The maximum V_{out} is package thermal limited, user should keep V_{out} under maximum power dissipation.

Electrical Characteristics ($V_{DD}=5V$, $T_A=25^\circ C$ unless otherwise noted)

Characteristic	Symbol	Conditions	Min.	Typ.	Max.	Unit	
Input voltage	V_{IH}	-	2	-	V_{DD}	V	
	V_{IL}	-	0	-	0.4	V	
Output leakage current	I_{OL}	$V_{OUT} = 24V$	-	-	0.5	μA	
Output current	I_{OUT}	$V_{OUT}=1V$ $R_{EXT}=900\Omega$	-	84	-	mA	
Current channel skew ¹	dI_{OUT1}	$V_{OUT}=1V$ $R_{EXT}=900\Omega$	-	± 2	± 3	%	
Current chip skew ²	dI_{OUT2}	$V_{OUT}=1V$ $R_{EXT}=900\Omega$	-	± 4	± 6	%	
Line regulation I_{OUT} vs. V_{DD} ³	$\%/dV_{DD}$	$4.5V < V_{DD} < 5.5V$ $R_{EXT}=900\Omega$, $V_{OUT} > 1V$	-	± 0.5	± 1	$\%/V$	
Load regulation I_{OUT} vs. V_{OUT} ⁴	$\%/dV_{OUT}$	$1V < V_{OUT} < 4V$, $R_{EXT}=900\Omega$, $V_{DD}=5V$	-	± 0.5	± 1	$\%/V$	
Pull-down resistor	R_{DOWN}	OE	-	500	-	K Ω	
Supply current	OFF	$I_{DD(OFF)1}$	$R_{EXT} = \text{Open}$, $OUT_1 \sim OUT_4 = \text{OFF}$	-	6	15	mA
		$I_{DD(OFF)2}$	$R_{EXT} = 900\Omega$, $OUT_1 \sim OUT_4 = \text{OFF}$	-	9	15	
	ON	$I_{DD(ON)}$	$R_{EXT} = 900\Omega$, $OUT_1 \sim OUT_4 = \text{ON}$	-	10	15	

1. Channel skew= $(I_{OUT} - I_{AVG}) / I_{AVG}$, where $I_{AVG} = (I_{OUT(max)} + I_{OUT(min)}) / 2$
2. Chip skew= $(I_{AVG} - I_{CEN}) / I_{CEN} * 100(\%)$, where I_{CEN} is the statistics distribution center of output currents.
3. Line regulation= $[I_{OUT}(V_{DD}=5.5V) - I_{OUT}(V_{DD}=4.5V)] / \{ [I_{OUT}(V_{DD}=5.5V) + I_{OUT}(V_{DD}=4.5V)] / 2 \} / (5.5V - 4.5V) * 100(\%/V)$
4. Load regulation= $[I_{OUT}(V_{OUT}=4V) - I_{OUT}(V_{OUT}=1V)] / \{ [I_{OUT}(V_{OUT}=4V) + I_{OUT}(V_{OUT}=1V)] / 2 \} / (4V - 1V) * 100(\%/V)$

Test Circuit for Electrical Characteristics

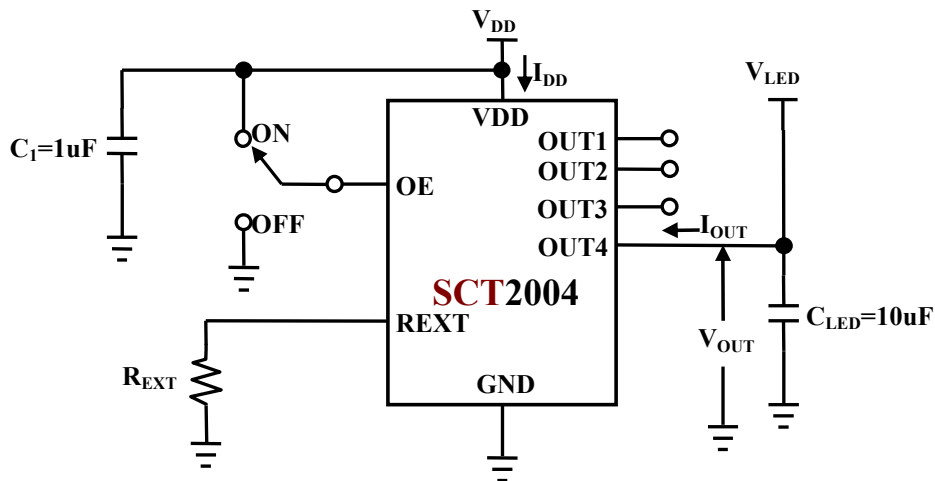

Switching Characteristics ($V_{DD}=5V$, $T_A=25^{\circ}C$ unless otherwise noted)

Characteristic	Symbol	Condition	Min.	Typ.	Max.	Unit	
Propagation delay time ("L" to "H")	OE - OUTn	t_{PLH}	$V_{DD} = 5V$ $V_{LED} = 5V$ $V_{IH} = V_{DD}$ $V_{IL} = GND$ $R_{EXT} = 900\Omega$ $R_L = 47\Omega$ $C_L = 10pF$ $C_1 = 1\mu F$ $C_{LED} = 10\mu F$	-	50	100	ns
Propagation delay time ("H" to "L")	OE - OUTn	t_{PHL}		-	30	160	ns
Pulse width	OE	t_w		80	-	-	ns
Output rise time of I_{OUT}		t_{OR}		-	10	25	ns
Output fall time of I_{OUT}		t_{OF}		-	10	25	ns

Test Circuit for Switching Characteristics

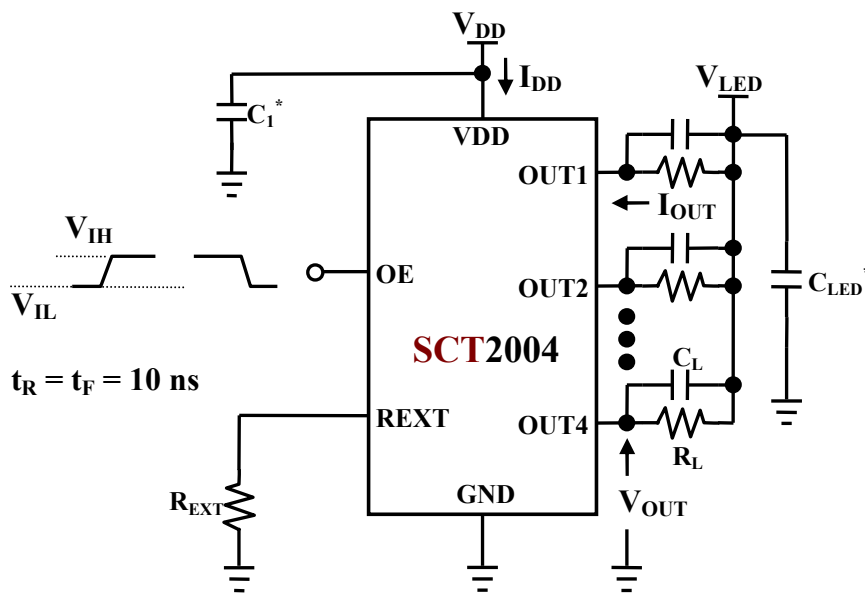

* Place the C_1/C_{LED} more close to IC VDD/OUT pin(not power supply) as possible.

Timing Waveform

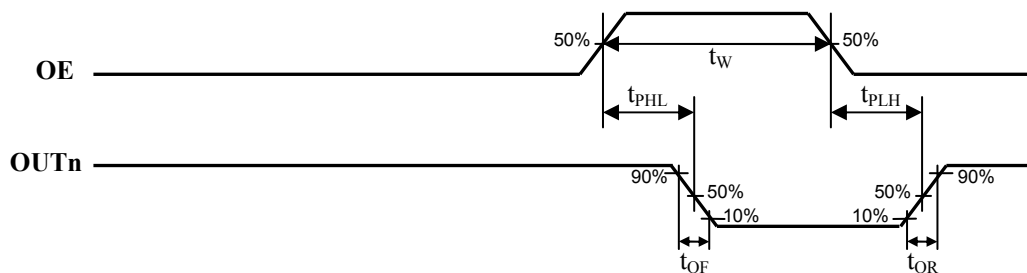

Adjusting Output Current

All SCT2004's output current (I_{OUT}) are set by one external resistor at pin REXT. The output current I_{OUT} versus resistance of R_{EXT} is shown as the following figure.

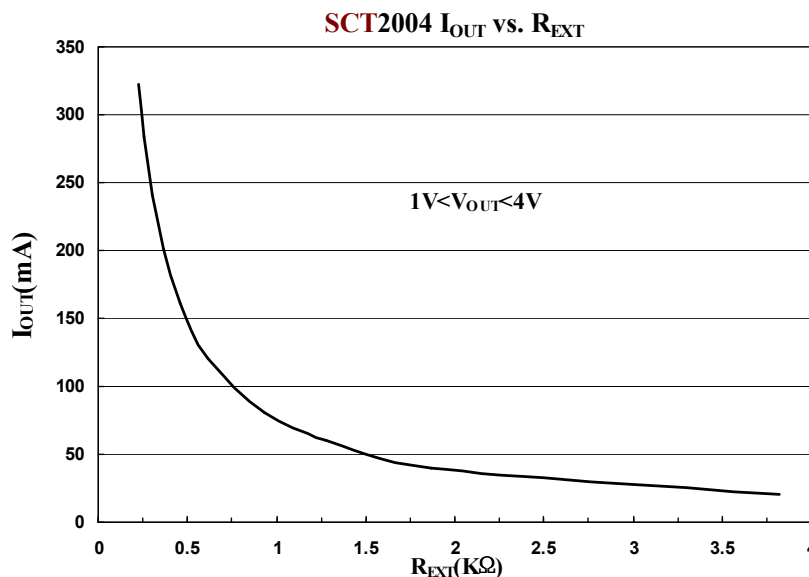

According to SCT2004' I-V curve, the output voltage should be larger than 1V to get 320 mA constant current. By applying proper output voltage, the SCT2004' output current set by an external resistor is approximate to: $I_{OUT} = 120(630 / R_{EXT})$ (mA) (chip skew < $\pm 6\%$). Thus the output current is set to be about 84mA at $R_{EXT} = 900\Omega$.

Output Characteristics

The current characteristic of output curve is flat. The output current can be kept constant regardless of the variations of LED forward voltage when $V_{OUT} > V_{DO}$ (drop-out voltage). The relationship between I_{OUT} and V_{OUT} is shown below. The output voltage should be kept as low as possible to prevent the SCT2004 from being overheated.

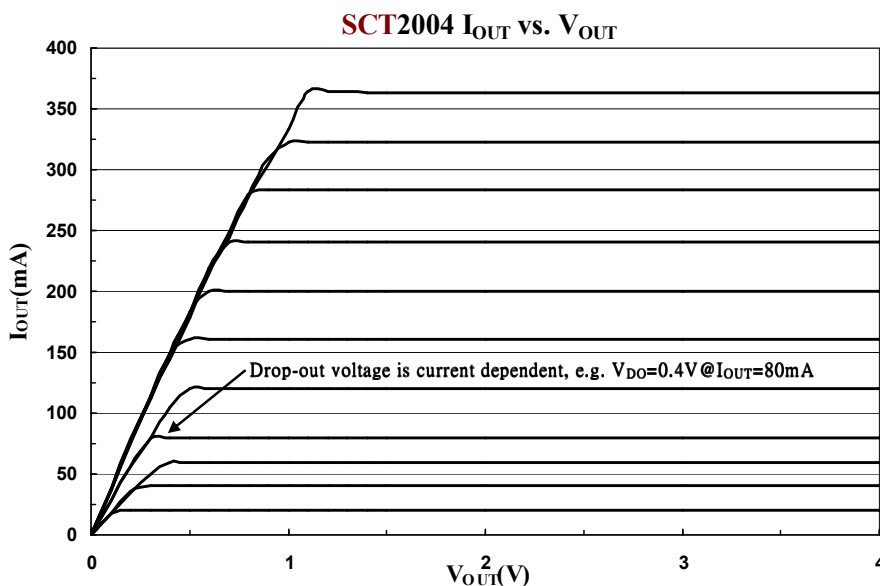

Maximum Power Dissipation

The maximum power dissipation ($P_{D(max)}$) of a semiconductor chip varies with different packages and ambient temperature. It's determined as $P_{D(max)} = (T_{J(max)} - T_A) / R_{TH(j-a)}$ where $T_{J(max)}$: maximum chip junction temperature is usually considered as 150°C, T_A : ambient temperature, $R_{TH(j-a)}$: thermal resistance. Since $P=IV$, for sinking larger I_{OUT} , users had better add proper voltage reducers on outputs to reduce the heat generated from the SCT2004.

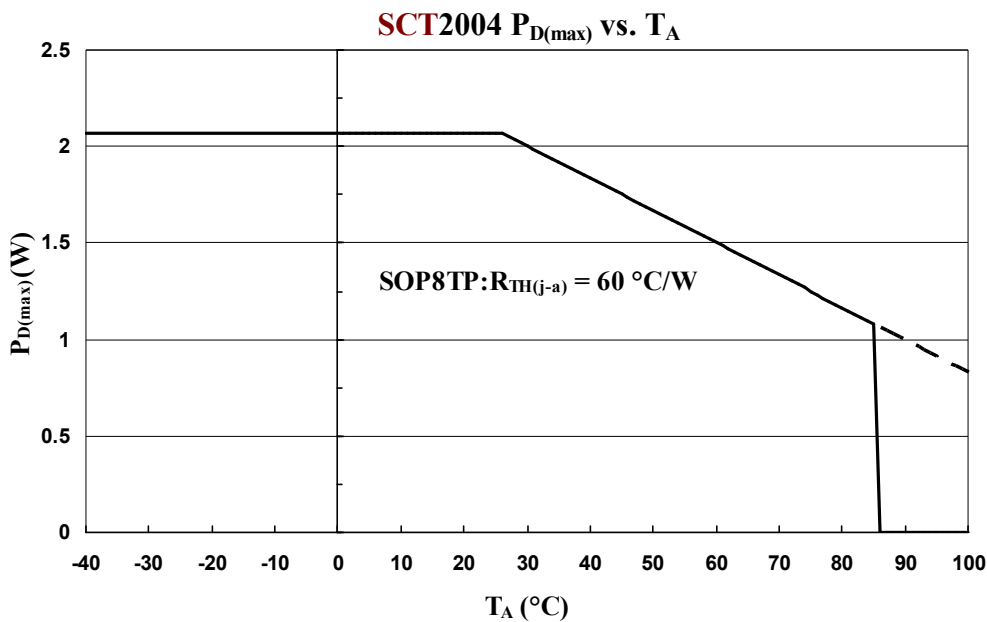

Limitation on Maximum Output Current

The maximum output current vs. duty cycle is estimated by:

$$I_{OUT(max)} = ((T_{J(max)} - T_A) / R_{TH(j-a)}) - (V_{DD} * I_{DD}) / V_{OUT} / \text{Duty} / N, \text{ where } T_{J(max)} = 150^\circ\text{C}, N = 4 (\text{all ON})$$

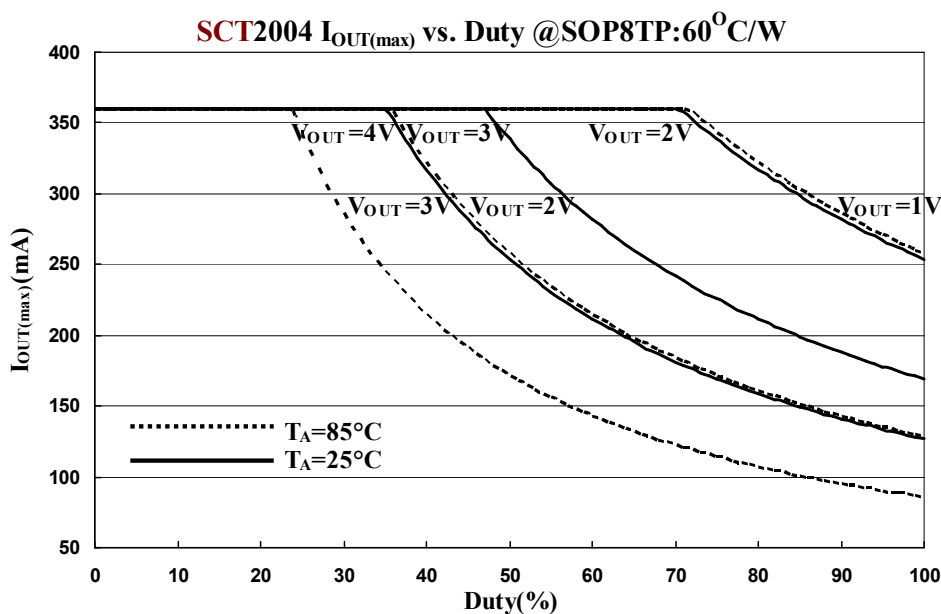

Load Supply Voltage (V_{LED})

The SCT2004 can be operated very well when V_{OUT} ranges from 1V to 4V. However, it is recommended to use the lowest possible supply voltage or set a voltage reducer to reduce the V_{OUT} voltage, at the same time reduce the power dissipation of the SCT2004. Follow the diagram instructions shown below to lower down the output voltage. This can be done by adding additional resistor or zener diode, thus $V_{OUT} = V_{LED} - V_{DROP} - V_F$.

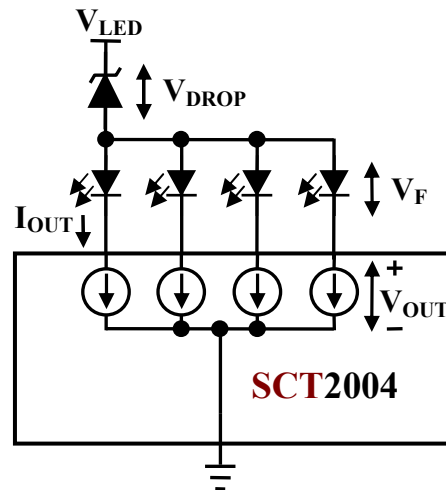
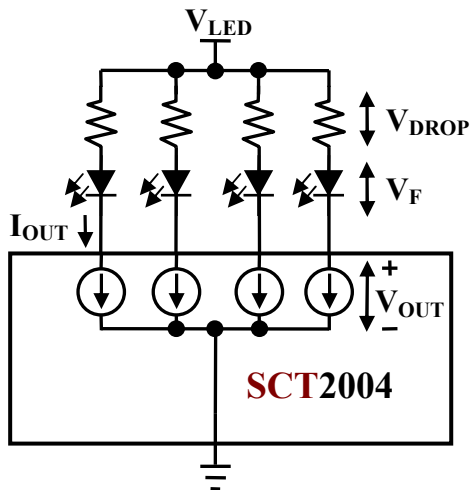

Typical Application Circuits

(1) Lighting with recommended $V_{LED}=5V$

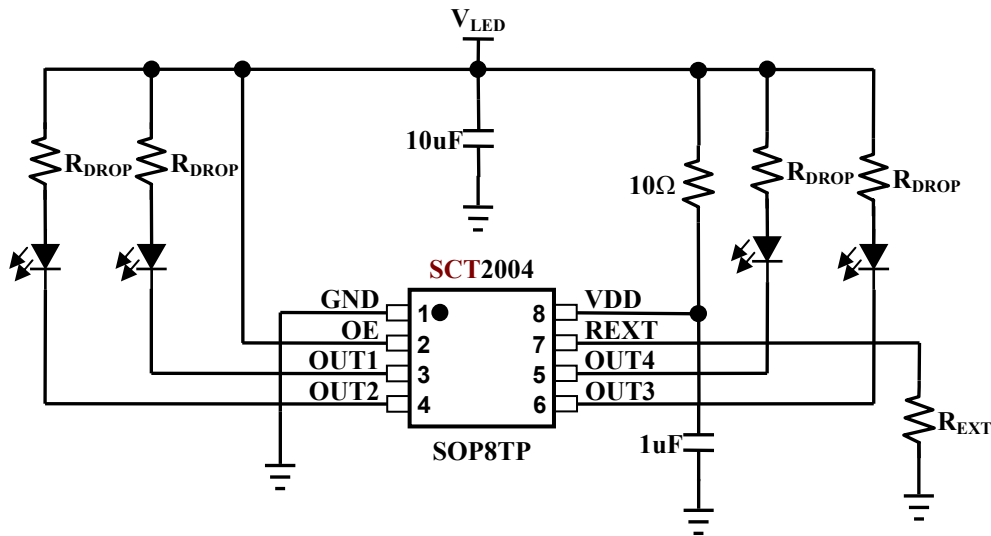

(2) Lighting with $V_{LED} > 5V$, e.g. $V_{LED}=12V/24V$

Components suggestion:

$$R_1 = (V_{LED} - V_Z) / (I_{DD} + I_Z)$$

If $V_{LED}=24V$, $V_Z=5.1V$, $I_Z=1mA$

$R_{EXT}=900\Omega$, $I_{DD(max)}=15mA$, then

$R_1 \sim 1.2K$ is obtained. Beware that:

I_{DD} is R_{EXT} dependent, the higher

R_{EXT} the lower I_{DD} , vice versa.

$$R_{DROP} = (V_{LED} - \eta * V_F - V_{DO}) / I_{OUT}$$

V_{DO} is the drop-out voltage of intended output current.

$$C_1 = 1\mu F$$

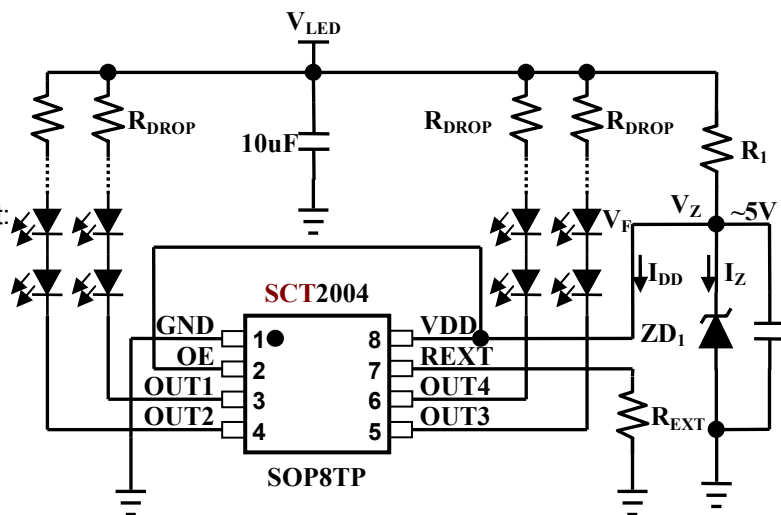

(3) Lighting with dimming control

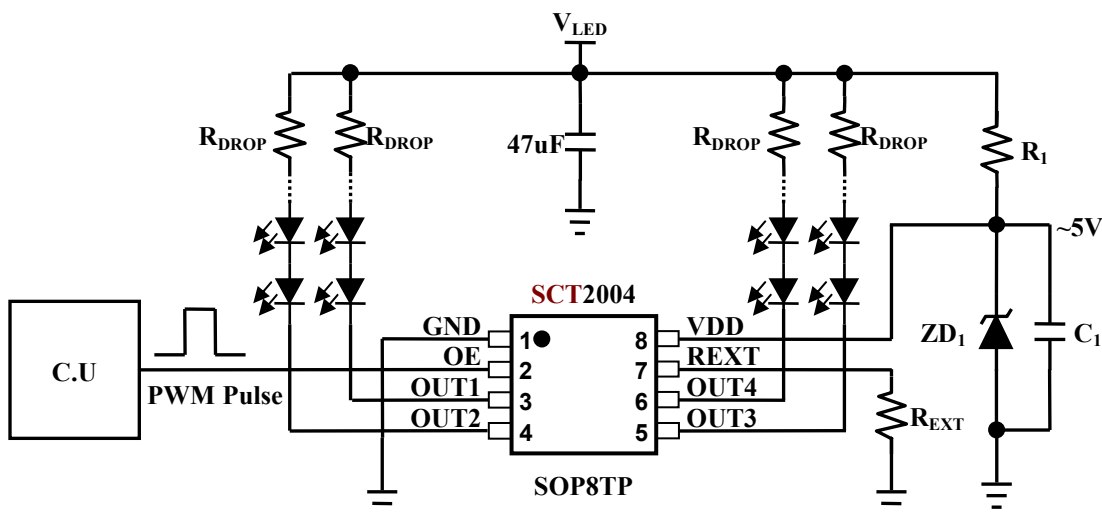

PCB Design Considerations

Use the following general guide-line when designing printed circuit boards (PCB) :

Decoupling Capacitor

Place a decoupling capacitor e.g. 1uF between VDD and GND pins of the SCT2004. Locate the capacitor as close to the SCT2004 as possible. The necessary capacitance depends on the LED load current and dimming frequency. Inadequate VDD decoupling can cause timing problems, and very noisy LED supplies can affect LED current regulation.

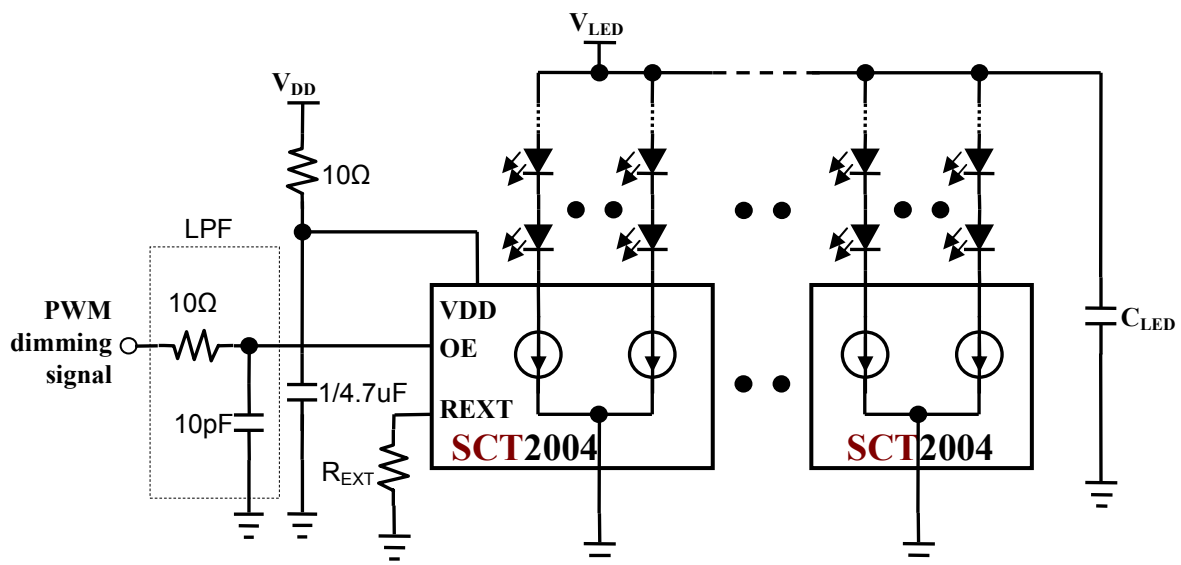

External Resistor (R_{EXT})

Locate the external resistor as close to the R_{EXT} pin in as possible to avoid noise.

Power and Ground

Maximizing the width and minimizing the length of VDD and GND trace improves efficiency and ground bouncing by effect of reducing both power and ground parasitic resistance and inductance. A small value of resistor, e.g., 10Ω (higher if I_{OUT} is larger) series in power input of the SCT2004 in conjunction with decoupling capacitor shunting the IC is recommended. Separating and feeding the LED power from another stable supply terminal V_{LED}, furthermore adding a capacitor C_{LED} greater than 10uF beside the LED are recommended. Please adapt C_{LED} according to total system current consumption.

EMI Reduction

To reduce the EMI radiation from system, an economical solution of RC low pass filter (LPF) is suggested to be used to lower the transient edge of PWM dimming signal OE, as shown in the figure above. Using at least four layers PCB board with two interior power and ground planes is a good scheme to decrease the signal current path which is the source of radiation emission. As a result, EMI radiation can be decreased.

Thermal Pad Consideration

The “thermal pad” (also named as “exposed pad”) SOP8 package beneath is NOT directly wired to ground terminal (pin1) internally. User should be aware of this electrical connection when designing the PCB board. In most application, connecting the thermal pad to system ground is strongly suggested.

In general, the heat generated from an IC is conducted to the PCB then radiates to the ambient. Thermal pad specifically increases the maximum power dissipation capability of the IC packages. To provide lower thermal resistance from the IC to the ambient air, PCB designers should layout larger thermal conduction areas on top layer (component side) and bottom layer as well as thermal vias, the more the better. In addition, connecting thermal via to the ground plane also increases thermal conduction areas, this improves the heat transfer efficiency at the same time greatly dissipates heat generated from the package. Furthermore, coating solder on bottom layer and selecting e.g. 2 oz. copper which will increase the total thickness of thermal conduction is an alternative.

When making the solder paste screen, an opening should be created for the thermal pad. This way the thermal pad can be electrically and thermally connected to the PCB. As the thermal pad is soldered on copper polygon, the chance of inadvertently shorting the thermal pad to traces routed underneath it could be eliminated.

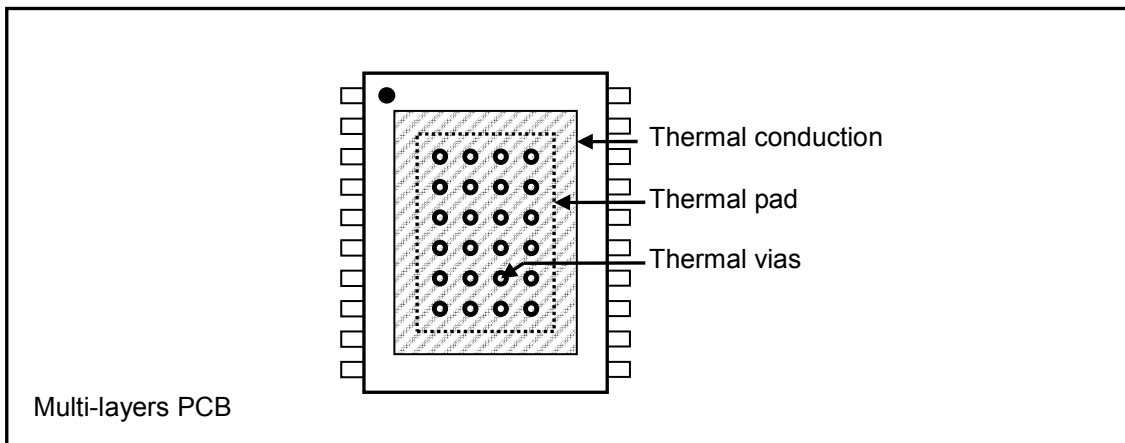
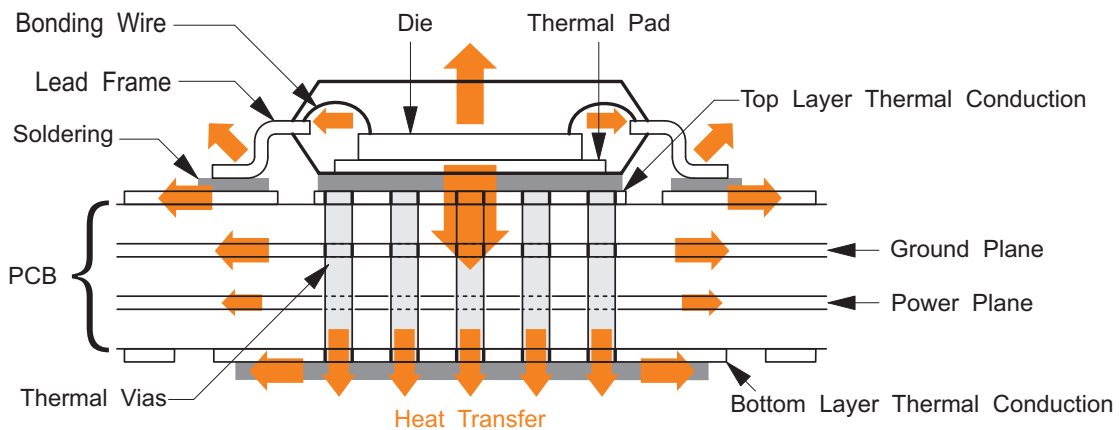

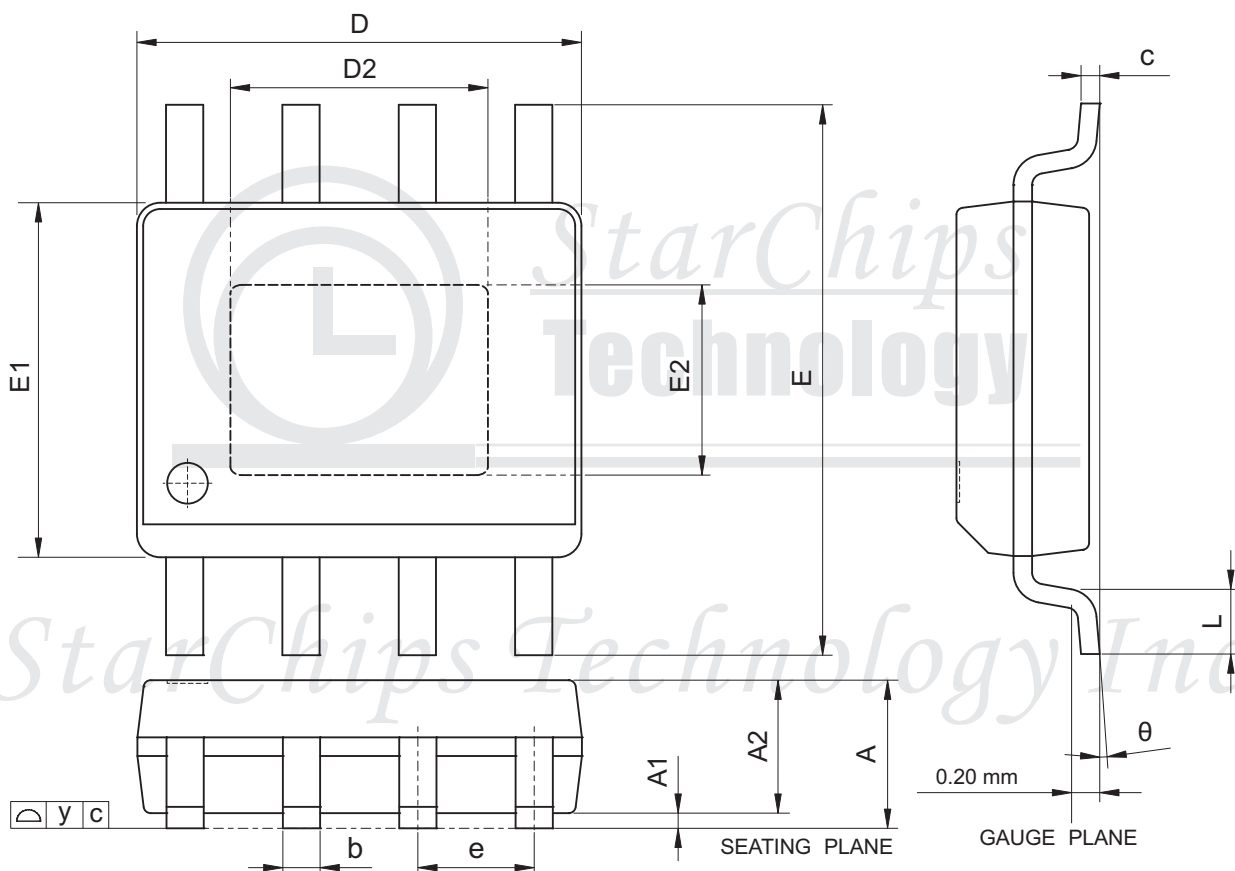
Package DimensionSOP8TP([check up-to-date version](#))

Symbol	Dimension (mm)			Dimension (mil)		
	Min.	Nom.	Max.	Min.	Nom.	Max.
A	1.40	1.50	1.60	55.1	59.1	63.0
A1	0.00	-	0.10	0.0	-	3.9
A2	-	1.45	-	-	57.1	-
b	0.33	-	0.51	13.0	-	20.1
c	0.19	-	0.25	7.5	-	9.8
D	4.80	-	5.00	189.0	-	196.9
E	5.80	6.00	6.20	228.3	236.2	244.1
E1	3.80	3.90	4.00	149.6	153.5	157.5
D2	-	3.30	-	-	130.0	-
E2	-	2.40	-	-	95.0	-
e	-	1.27	-	-	50.0	-
L	0.40	-	1.27	15.7	-	50.0
y	-	-	0.10	-	-	3.9
θ	0°	-	8°	0°	-	8°

Revision History([check up-to-date version](#))

Data Sheet Version	Remark
V02_02	Thermal pad description added

Information provided by StarChips Technology is believed to be accurate and reliable. Application circuits shown, if any, are typical examples illustrating the operation of the devices. StarChips can not assume responsibility and any problem raising out of the use of the circuits. StarChips reserves the right to change product specification without prior notice.

StarChips Technology, Inc.

www.starchips.com.tw

4F, No.5, Technology Rd., Science-Based Industrial Park, Hsin-Chu, Taiwan, R.O.C.

Tel: +886-3-577-5767 # 555