

REV.	DESCRIPTION	DRAWN	CHECKED	APPROVED
A	NEW RELEASE	LJC 01/17/09'	~	

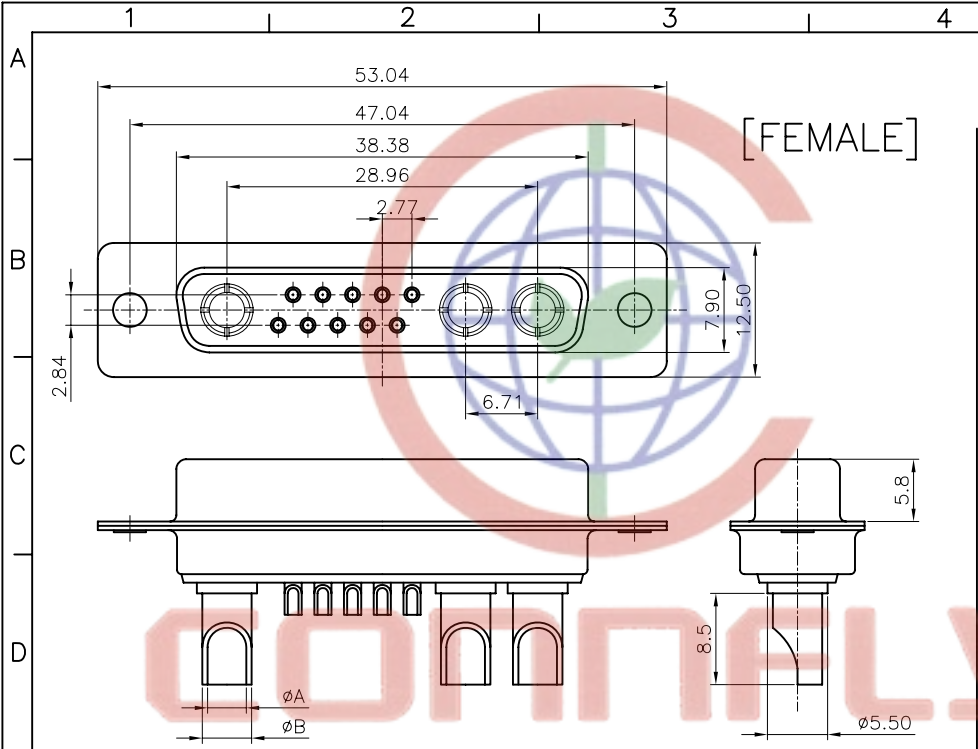

NOTES:

- ELECTRICAL CHARACTERISTICS:
 - CONTACT RESISTANCE: 20mΩ Max. INITIAL.
 - DIELECTRIC WITHSTANDING VOLTAGE: 500V AC(rms)FOR 1 MINUTE.
 - INSULATION RESISTANCE: 1000MΩ Min.
 - CURRENT RATING: 5A.
 - VOLTAGE RATING: 300V
- ENVIRONMENT CHARACTERISTICS:
 - TEMPERATURE RANGE: -45° C ~ +110° C.
- MECHANICAL CHARACTERISTICS:
 - DURABILITY: 500 CYCLES.
 - CONTACT RETENTION FORCE: 1Kgf MINIMUM.
- MATERIALS:
 - SHELL: SPCC.
 - CONTACT: COPPER ALLOY.
 - INSULATOR: THERMOPLASTIC UL 94V-0, GLASS FIBER FILLED.
- PART NUMBER CODE:

DS1033-03- X X X X X

- └ CURRENT RATING
 - 1: 10A
 - 2: 20A
 - 3: 30A
 - 4: 40A
- └ CONTACT PLATING
 - 8: FULL GOLD FLASH
 - C: FULL 3u: GOLD
- └ SHELL PLATING
 - N: FORNT SHELL NICKEL, BACK SHELL TIN
- └ HOUSING COLOR
 - B: BLACK
 - W: WHITE
 - L: BLUE
- └ CONNECTOR TYPE
 - M: MALE
 - F: FEMALE

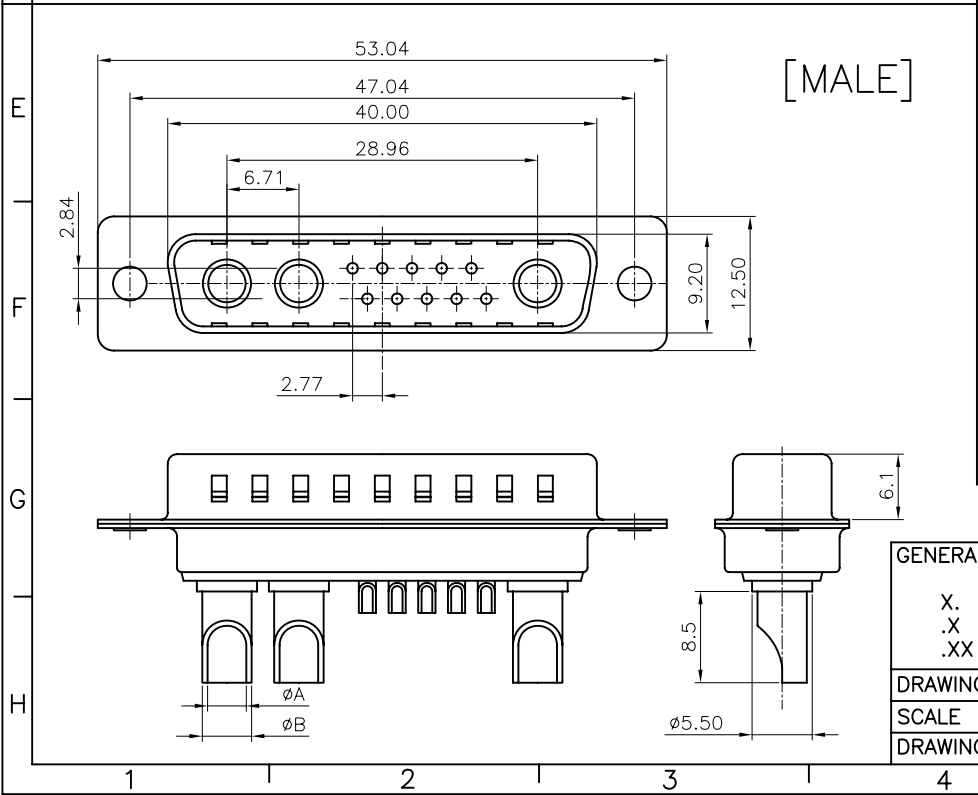

TYPE	CURRENT RATING	φA	φB
1	10A	φ1.7	φ2.5
2	20A	φ2.7	φ3.6
3	30A	φ3.6	φ4.5
4	40A	φ4.6	φ5.5

GENERAL TOLERANCE	ANGLE TOLERANCE	PROJECTION	TITLE
X. ±0.60	X. ±5°	mm	MACHINE PIN D-SUB 10+3
.X ±0.38	.X ±3°		SOLDER TYPE
.XX ±0.25	.XX ±2°		SHEET SIZE A4
DRAWING TYPE	CUSTOMER	SERIES	DS1033-03 SERIES
SCALE	1:1	SHEET	1 OF 1
DRAWING NO.	C-DS1033-03-XXXX-A	晨翔电子有限公司 CONNFLY CONNFLY ELECTRONIC CO. LTD	