



# DEGSON ELECTRONICS CO., LTD.

## Product Specification



| Specification  | Model                           | PCS              |
|--|---------------------------------|------------------|
| (1) Ground Terminal Block  | MK 35-PE                        | 20               |
| (2) Rail Hdder   | SH2                             | 10               |
| (3) Zack Strip   | DEK 6                           |                  |
| Thickness / Width [mm]   | 16 / 58 mm                      | 16 / 58 mm       |
| Height [mm]  | - / - / 67.5 mm                 | 60 / 67.5 / - mm |
| Wire Size [mm <sup>2</sup> ] / AWG   | 10-35 mm <sup>2</sup> / 8-2 AWG |                  |
| Stripping Length [mm]  | 20 mm                           |                  |
| Tightening Torque: Screw Thread / Tightening Torque - / [Nm]               | M6 / 2.5-5.0Nm                  |                  |
| Tightening Torque(Fixing Screw): Screw Thread / Tightening Torque - / [Nm] | M4 / 1.2-1.6Nm                  |                  |
| Insulating Material / Inflammability Class                                 | PA / V-0                        |                  |

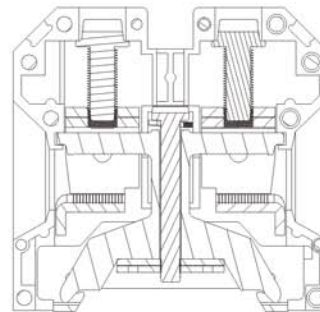
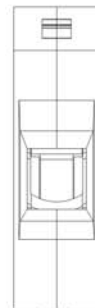
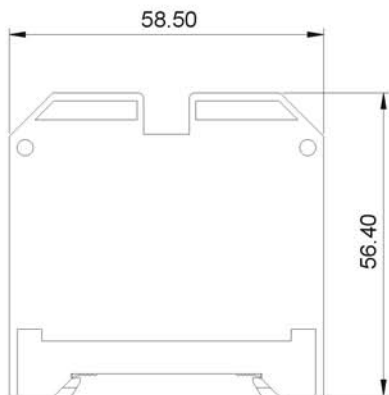
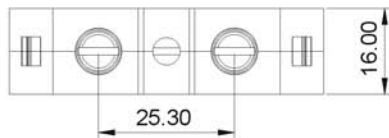

### HOW TO ORDER:



Series No.    No. of Pole  
 Color

|         |          |                    |
|---------|----------|--------------------|
| 1 Gray  | 4 Green  | 7 Trans-<br>parent |
| 2 Blue  | 5 Orange | 8 Yellow           |
| 3 Black | 6 Red    | 9 White            |

|  |                                     |
|--|-------------------------------------|
|  | <b>DEGSON ELECTRONICS CO., LTD.</b> |
|  | NAME <b>MK 35-PE</b>                |