

REV. 版本	ECN NO. 变更说明	DATE 日期
01-06	ADD P/N	09/11/24
07	ADD P/N	09/12/30
08	ADD P/N	10/01/03
09	ADD P/N	2014.02.21
10	修正09错误	2014.03.01
11-12	新增规格	2014.07.21

A

A

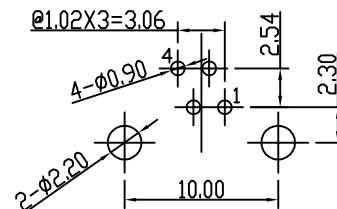
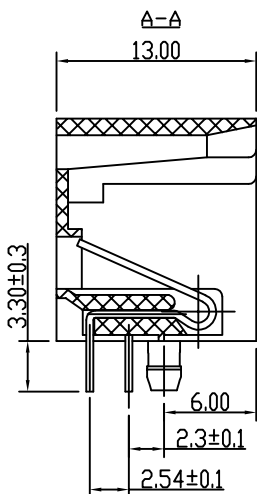
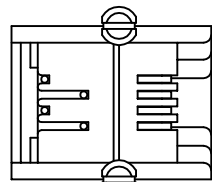
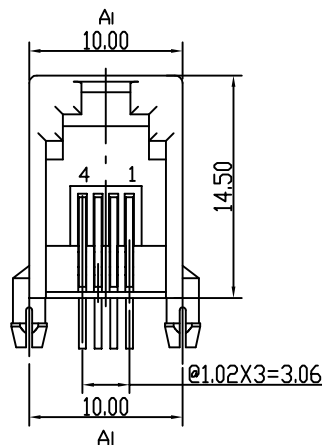

PC BOARD LAYOUT THICKNESS=1.6MM

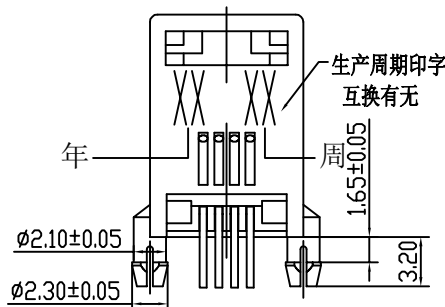

电气特性:

1. 额定电压: 125 VAC RMS
2. 额定电流: 1.5 AMP
3. 接触电阻: 20 mΩ MAX.
4. 绝缘电阻: 1000 MΩ MIN. @500 VDC
5. 耐压强度: 1000 VAC RMS 60Hz, 1分钟

机构特性:

1. 塑壳材质: PBT;
2. 圆针材质: 磷青铜, ∅0.46mm;
3. 圆针电镀: 镍底, 表面全部镀金;
4. 插入/拔出力: 30N Max.
5. 配合强度: 50N 60S±5S.
6. 可靠性: 最少750次插拔

环境特性:

1. 储存温度: -40°C~+85°C 相对湿度<80%.
2. 工作温度: -40°C~+85°C

NOTES:

ELECTRICAL:

1. VOLTAGE RATING : 125 VAC RMS.
2. CURRENT RATING : 1.5 AMP.
3. CONTACT RESISTANCE : 20 MILLIOHMS MAX.
4. INSULATION RESISTANCE : 1000 MEGOHMS MIN @ 500 VDC.
5. DIELECTRIC STRENGTH : 1000 VAC RMS 60Hz, 1MIN.

MECHANICAL:

1. HOUSING MATERIAL : PBT .
2. CONTACT MATERIAL : PHOSPHOR BRONZE ∅0.46mm.
3. CONTACT PLATING : GOLD PLATING OVER NICKEL.
4. MATING/UNMATING FORCE : 30N Max..
5. RETENTION STRENGTH : 50N 60S±5S .
6. OPERATING LIFE : 750 CYCLES MIN.

ENVIRONMENTAL:

1. STORAGE : -40°C~+85°C RELATIVE HUMIDITY<80%
2. OPERATION : -40°C~+85°C

C

C

D

D

RoHS Compliant

5521 4P 无耳 插座

CZT ® 温州意华接插件股份有限公司 WENZHOU YIHUA CONNECTOR CO., LTD		TOLERANCES 公差 .0 ± 0.25 .00 ± 0.20 .000 ± 0.10		Material: 材质 SEE NOTE	Designed: 设计 廖永生	NAME: 名称 RJ22 5521 4P WITHOUT EAR JACK
第一视角	A4 SIZE	SCALE 比例 1:1	UNIT 单位 mm	Finish: 电镀 SEE NOTE	Checked: 审核	DWG NO: 图号 E55Q07082402
		CUSTOMER: 客户 N/A	MODEL NO: 料号 N/A	ANGLES ± 0.5	SHEET 第 1 页 共 2 页	Approved: 核准
						PART NO: 料号 SEE NOTE
						REV. 版本 12