

REV 版本	ECN NO. 变更说明	DATE 日期
01	增加品号	09.09.08
02	增加塑壳图号	09.12.30
03	增加品号	12.05.21
04	增加品号	13.11.28
05	增加新料号	13.12.19

SPECIFICATION NOTES:

ELECTRICAL:

- VOLTAGE RATING: 125 VAC RMS
- CURRENT RATING: 1.5 AMP
- CONTACT RESISTANCE: 20mΩ MAX.
- INSULATION RESISTANCE: 1000MΩ MIN. AT 500V DC.
- DIELECTRIC STRENGTH: 1000 V AC OR 1500V DC RMS AT 0.5mA 50 Hz / 60 Hz FOR 1 MINUTE

MECHANICAL:

- HOUSING&INSERT&MATERIAL: SEE TABLE
- CONTACT MATERIAL: DIA. PHOSPHOR BRONZE $\phi=0.46\text{MM}$
- PLATING: GOLD PLATING AT CONTACT AREA, NICKEL 30U MIN. OVER ALL
- OPERATING LIFE: 750 CYCLES MIN.
- MATING/UNMATING FORCE: 30N/3.06KG MAX.
- RETENTION STRENGTH: 50N MIN. FOR 60S±5S

ENVIRONMENTAL:

- STORAGE: -40° C TO +85° C RELATIVE HUMIDITY<80%
- GUARANTEE PERIOD: 12 MONTHS
- OPERATION: -40° C TO +85° C
- WAVE SOLDERING TEMPERATURE: 260±5° C 5-10 SECONDS. MATES WITH MODULAR PLUG CONFORMING TO FCC PART 68, SUBPART F.

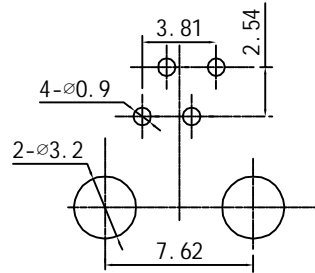
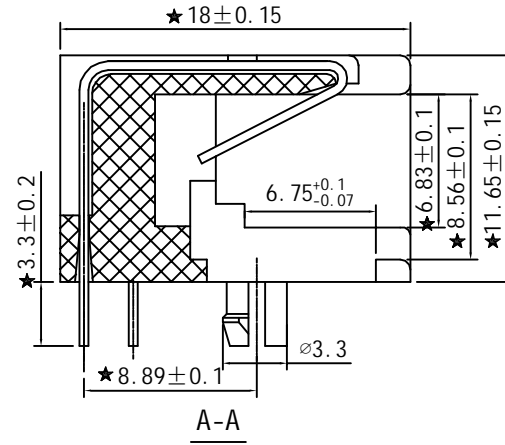
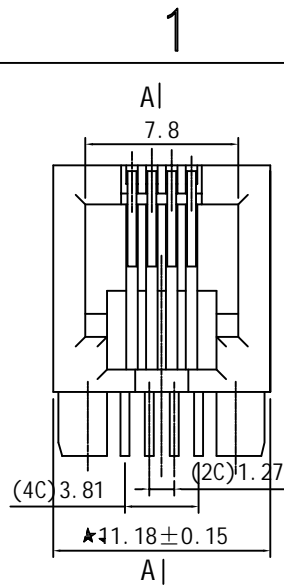

RECOMMENDED P.C.B LAYOUT (COMPONENT SIDE)
P.C.B THICKNESS=1.60MM (TOLERANCE= ±0.05)

电气特性

- 额定电压: 125 VAC RMS
- 额定电流: 1.5 AMP
- 接触电阻: 20 mΩ MAX
- 绝缘电阻: 1000 MΩ MIN. @500 VDC
- 耐压强度: 1000 V AC 或 1500V DC RMS @ 0.5mA 50 Hz 或 60 Hz 一分钟

机构特性:

- 塑壳材质: 见表格
- 圆针材质: 磷青铜, $\phi 0.46\text{MM}$
- 圆针电镀: 全区先镀镍底30U MIN., 后依订单单次镀金厚度, 如表说明
- 可靠性: 最少750次插拔
- 插入/拔出力: 30N/3.06KG MAX.
- 配合强度: 50N 60S±5S.

环境特性

- 储存温度: -40°C~+85°C
- 相对湿度<80%
- 储存时间: 12个月
- 工作温度: -40°C~+85°C
- 波峰焊温度: 260±5°C 5~10S

注: 1. 带"★"尺寸为重点管控尺寸
2. 塑壳图号: YZ2J0216



13	10215344A009	5321插座 4P4C G/F	尼龙46黑(环保料)	8H
12	10215344A008	5321插座 4P4C 0.6U	普通PBT黑(环保料)	8H
11	B531N-4403-M003	5321插座 4P4C 3U	普通PBT灰(环保料)D8003	24H
10	1B531N-4406-U001	5321插座 4P4C 6U	尼龙66B30黑(环保料)	24H
9	1B531N-4206-M002	5321插座 4P2C 6U	普通PBT黑(环保料)	24H
8	1B531N-44GF-M001	5321插座 4P4C G/F	普通PBT灰(环保料)D8003	8H
7	1B531N-44GF-U002	5321插座 4P4C G/F	尼龙66B30黑(环保料)	8H
6	1B531N-4403-U002	5321插座 4P4C 3U	尼龙66B30黑(环保料)	24H
5	1B531N-4430-M006	5321插座 4P4C 30U	普通PBT黑(环保料)	48H
4	1B531N-4415-M006	5321插座 4P4C 15U	普通PBT黑(环保料)	48H
3	1B531N-4406-M006	5321插座 4P4C 6U	普通PBT黑(环保料)	24H
2	1B531N-4403-M006	5321插座 4P4C 3U	普通PBT黑(环保料)	24H
1	1B531N-44GF-M006	5321插座 4P4C G/F	普通PBT黑(环保料)	8H
NO.	RoHS PART NUMBER	NAME	DESCRIPTION	SALT SPRAY

RoHS COMPLIANT

CZT® 温州意华接插件股份有限公司
WENZHOUIYHUA CONNECTOR CO., LTD

TOLERANCES

公差
00~15 ±0.15
15~30 ±0.20
30~ ±0.25
ANGLES: ±1°

Material:

材质 SEE NOTE

Finish:

电镀 SEE NOTE

SHEET 1 OF 1
第 1 页 共 1 页

设计

Checked:
审核

Approved:
核准

名称

DWG NO.

图号

PART NO.
料号

5321插座 4P系列

YZ3P0137

SEE TABLE

REV.
版本

05



A4
SIZE

SCALE
比例 1:1

UNIT
单位 mm

CUSTOMER:
客户 N/A

MODEL NO:
料号 N/A

1

2

3

4