

A

B

C

D

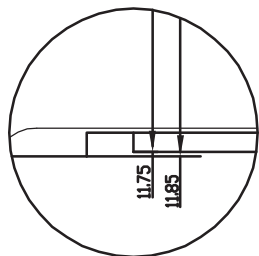

细节 I
比例 6:1

电气特性:

1. 额定电压: 125 VAC RMS
2. 额定电流: 1.5 AMP
3. 接触电阻: 20mΩ MAX.
4. 绝缘电阻: 1000MΩ MIN. @500 VDC
5. 耐压强度: 1000 VAC RMS 60Hz, 1分钟

NOTES:

ELECTRICAL:

1. VOLTAGE RATING : 125 VAC RMS.
2. CURRENT RATING : 1.5 AMP.
3. CONTACT RESISTANCE : 20 MILLIOHMS MAX.
4. INSULATION RESISTANCE : 1000 MEGOHMS MIN @ 500 VDC.
5. DIELECTRIC STRENGTH : 1000 VAC RMS 60Hz, 1MIN.

MECHANICAL:

1. HOUSING MATERIAL : PBT/PA66 UL94V-0.
2. CONTACT MATERIAL : PHOSPHOR BRONZE $\phi 0.45\text{mm}$.
3. PLATING : GOLD PLATING OVER NICKEL.
4. SHIELD : BRASS T=0.2 PLATED NICKEL FOR ALL.
5. MATING/UNMATING FORCE : 30N Max..
6. RETENTION STRENGTH : 30N FOR 60s±5s .
7. OPERATING LIFE : 750 CYCLES MIN.

RoHS Compliant

CZT 温州意华接插件股份有限公司
WENZHOU YIHUA CONNECTOR., LTD

TOLERANCES
公差

00~15 ± 0.15
15~30 ± 0.20
30~ ± 0.25

ANGLES ±1°

Material: 材质 SEE_NOTE

Finish: 电镀 SEE_NOTE

SHEET 1 OF 1
第 1 页 共 1 页

Designed: 设计 杨光权

Checked: 审核

Approved: 核准

NAME: 名称

DWG NO: 图号

PART NO: 料号

RJ45 1X1 5321 8P-S SPLIT PEG

E53QWY-1077-5

SEE_NOTE

REV. 版本

05

1

2

3

4

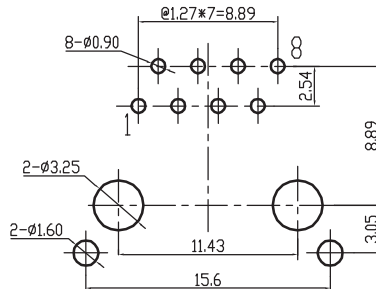
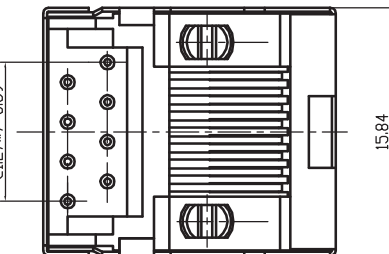
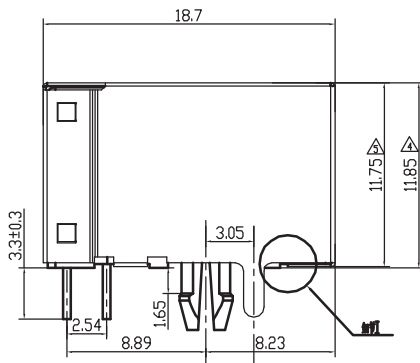
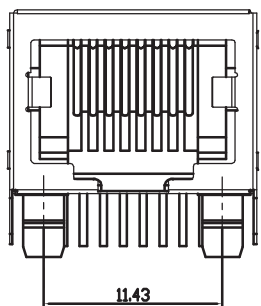

PC Board Layout
Thickness=1.6mm

机构特性:

1. 塑壳材质: PBT/PA66, UL94V-0;
2. 圆针材质: 磷青铜, $\phi 0.45\text{mm}$;
3. 圆针电镀: 全部镀金 (见料号表格), 镍底;
4. 铁壳材质: 黄铜 T=0.2mm, 镀镍.
5. 镀插入/拔出力: 30N Max.
6. 配合强度: 30N FOR 60s ± 5s.
7. 可靠性: 最少750次插拔.

环境特性:

1. 储存温度: -10°C~+40°C 相对湿度<80%.
2. 工作温度: -40°C~+85°C

ENVIRONMENTAL:

1. STORAGE : -10°C~+40°C RELATIVE HUMIDITY<80%
2. OPERATION : -40°C~+85°C

MATES WITH MODULAR PLUG CONFORMING TO FCC PART 68, SUBPART F.
ROHS PART NUMBER:

REV04: 根据品质异常单QA ZP30110728, 修改包壳以消除间隙

- 1
- 2
- 3

P/N 料号	DESCRIPTION 描述	CONTACT PALTING GOLD电镀	MATERIAL 材质
B531S-8803-M005	RJ45 1X1 5321 8P8C-S WITH SPLIT PEG	3u"	PBT BLACK 黑色
B531S-88GF-M005	RJ45 1X1 5321 8P8C-S WITH SPLIT PEG	G/F	PBT BLACK 黑色
B531S-8806-M002	RJ45 1X1 5321 8P8C-S WITH SPLIT PEG	6u"	PBT BLACK 黑色
B531S-8803-U001	RJ45 1X1 5321 8P8C-S WITH SPLIT PEG	3u"	PA66 BLACK 黑色
B531S-8806-U001	RJ45 1X1 5321 8P8C-S WITH SPLIT PEG	6u"	PA66 BLACK 黑色
B531S-8830-M002	RJ45 1X1 5321 8P8C-S WITH SPLIT PEG	30u"	PBT BLACK 黑色

5321 单胞 8P8C 包壳香菇脚 插座

A

B

C

D

1

2

3

4