

REVISION RECORD				
REV	ECN	DESCRIPTION	DRFT	DATE

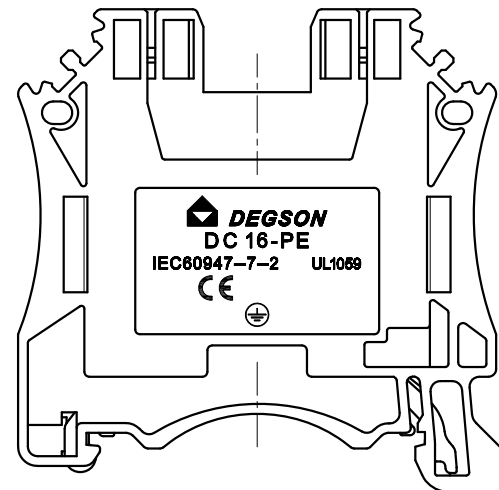
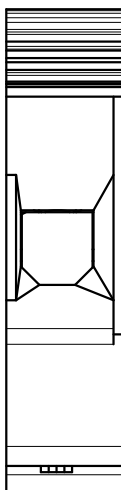
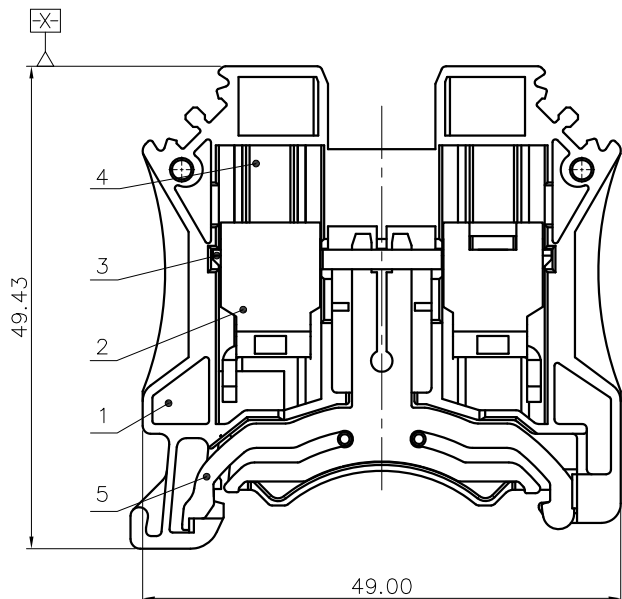
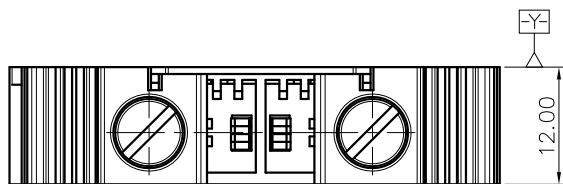

NOTES1:

- UL Standard
- 1.Torque value : M5 , 27.0Lb.in
- 2.Wire range : 14~3AWG

IEC Standard

1. Pollution degree	3
Overvoltage category	III
Rate impulse voltage(KV)	8.0KV
Rate voltage(V)	/ V
Rate current(A)	/ A

- 2.Torque value : M5 , 2.5N·m
- 3.Wire range : 1.5~25mm<sup>2</sup>

NOTES2:

- 1.Dimension shall be interpreted per ASME Y14.5-2009
- 2.Stripping length : 12~13mm
- 3.Operating temperature: -40°C~+105°C
- 4.Undimensioned tolerances:

Pitch range in mm		Nominal dimension range in mm				Tolerances		
TO	Over TO	TO	Over TO	TO	Over TO	0.1/10	±	
6	10	10	30	30	60	100	150	±2'
±0.15	±0.20	±0.30	±0.30	±0.50	±0.70	±1.00	±1.30	

- 5.RoHS Compliance

ITEM	NAME OF PART	MATERIAL	NOTES
5	Grounding	Copper alloy	Sn plated
4	Screw	Steel	M5/Zn plated
3	Current Carrier	Copper	Sn plated
2	Cage	Steel	M5/Zn plated
1	Housing	PA66	UL94V-0

DETACHED LISTS	PART NO.:	/		
	APPD:	/		
	CHKD:	/		
	DRFT:	/		
NAME:		宁波高松电子有限公司 NINGBO DEGSON ELECTRICAL CO., LTD		
TITLE: CUSTOMER DRAWING		DC16-PE-01P-1C-00A(H)		
DRAWING NO.:		/		
THIRD ANGLE PROJECTION				
MM (INCH)		DO NOT SCALE DRAWING		
REV	DO	SHEET	1/1	
SCALE	1:1			