

REVISION RECORD

REV	ECN	DESCRIPTION	DRFT	DATE
-----	-----	-------------	------	------

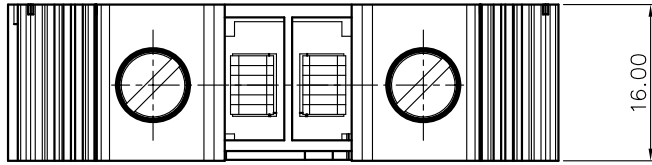

DC35-PE - 01P - 1C - 00A (H)
 (RoHS)
 00A-(Standard)
 (Color):C.(Green-yellow)
 (Series No.)(Poles)(Single Pitch)

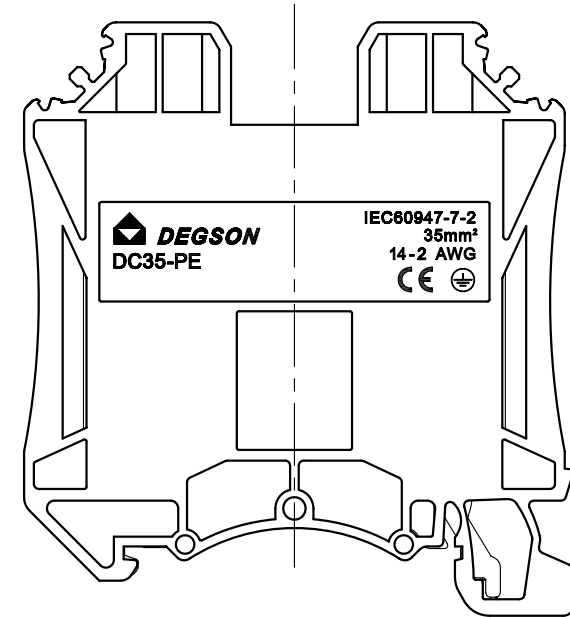
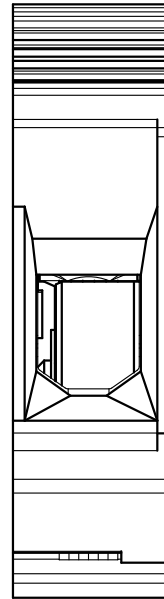
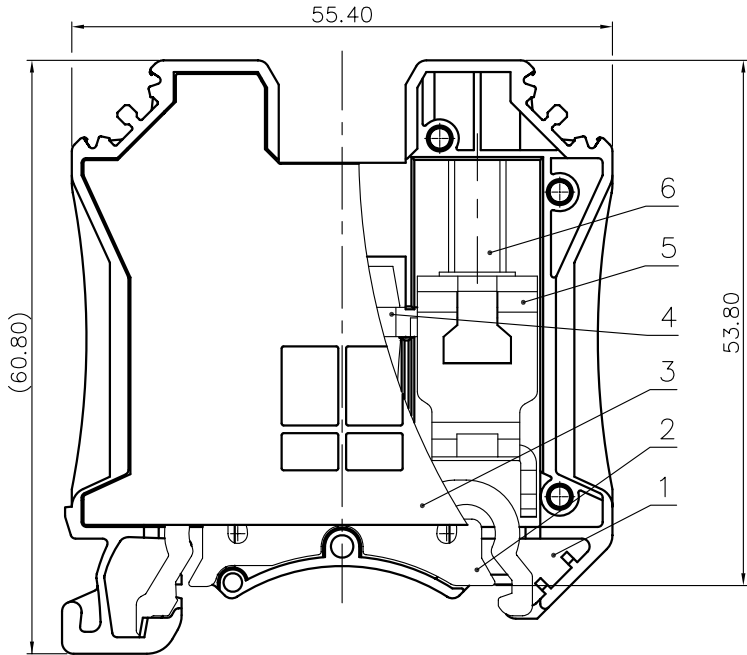

NOTES1:

UL Standard

- 1.Torque value : M6 , 31Lb.in
- 2.Wire range : 14~2AWG

IEC Standard

1. Pollution degree	3
Overtoltage category	III
Rate impulse voltage(KV)	8.0KV

- 2.Torque value : M6 , 3.5N·m
- 3.Wire range : 2.5~35mm²

NOTES2:

- 1.Dimension shall be interpreted per ASME Y14.5-2009
- 2.Stripping length : 14~16mm
- 3.Operating temperature:-40°C~+105°C
- 4.Undimensioned tolerances:

Pitch range in mm		Nominal dimension range in mm				—	∇
TO	Over	TO	Over	TO	Over	0.1/10	
6	10	24	30	60	100	150	
±0.15	±0.20	±0.30	±0.30	±0.50	±0.70	±1.00	±1.30
							±2'

5.RoHS Compliance

DETACHED LISTS	PART NO.:	/	宁波高松电子有限公司 NINGBO DEGSON ELECTRICAL CO., LTD			
	APPD:	/	NAME: DC35-PE-01P-1C-00A(H)			
	CHKD:	/	TITLE: CUSTOMER DRAWING			
	DRFT:	/	DRAWING NO.:	/	REV	D0-1
THIRD ANGLE PROJECTION		DO NOT SCALE DRAWING MM (INCH)	SHEET	1/1	SCALE	1:1