

深圳市炬烜科技有限公司  
CHIP SUN TECHNOLOGY CO., LTD

**APPROVAL  
SHEET**



CUSTOMER: \_\_\_\_\_  
DESCRIPTION: SMD3225 10.000MHz Quartz Crystal Oscillator  
MANUFACTURER PART NO.: FXO10.000M3.3SM3-25DEW  
CUSTOMER PART NO: \_\_\_\_\_  
USED IN MODEL: \_\_\_\_\_  
REVISION A1

承 认 APPROVAL		
工程部 TECHNOLOGY DEPT.	品质部 QUALITY DEPT.	采购部 PURCHASING DEPT.

Date: March 17, 2023



深圳市炬烜科技有限公司

CHIP SUN TECHNOLOGY CO., LTD

地址 ADD: 深圳市龙华新区大浪腾龙路淘金地电子商务孵化基地 B 座 206

Rm. 206, Tower B, Taojindi Building, Tenglong Road, Dalang Street,

Longhua New District, Shenzhen, China

电话 TEL: 86-755-83458796 传真 FAX: 86-755-83459818

网址 WEB ADD: <http://www.chinachipsun.com>

E-MAIL: [sales01@chinachipsun.com](mailto:sales01@chinachipsun.com)

<u>Rev</u>	<u>Revise page</u>	<u>Revise contents</u>	<u>Date</u>	<u>Ref.No.</u>	<u>Reviser</u>
A1	ALL	Initial released	2023.03.17	N/A	DavidJiang

<b>CHIP SUN TECHNOLOGY CO., LTD</b>		
<b>DESCRIPTION</b>	OSC-SMD3225 10.000MHz ±25ppm 3.3V	Page:
<b>DATE</b>	2023-03-17	2 / 11

# 1. QUARTZ CRYSTAL OSCILLATOR SPECIFICATION

1.1 Frequency :	$f_0$	10.000MHz
1.2 Holder Type :		SMD3225
		±25ppm Overall
1.3 Frequency Stability :	$f_{STAB}$	Temperature stability is Inclusive of all conditions: Calibration Tolerance at +25°C, frequency stability over the operating temperature range, supply voltage change, output load changes, shock, vibration, and 1st year aging at +25°C.
1.4 Supply Voltage :	$V_{DD}$	3.3V <sub>DC</sub> ±10%
1.5 Input Current :	$I_{DD}$	10mA max
1.6 Operable temperature range :	$T_{OPR}$	-40°C To +85°C
1.7 Storage temperature range :	$T_{STG}$	-55°C To +125°C
1.8 Symmetry :	SYM	45~55% (at 50% VDC)
1.9 Rise& Fall Time :	$T_r / T_f$	5nS max
1.10 Output Load :	$R_L$	HCMOS 15pF
1.11 Output Low Level :	$V_{OL}$	10% $V_{DD}$ max
1.12 Output High level :	$V_{OH}$	90% $V_{DD}$ min
1.13 Output Wave form :		Square
1.14 Pin 1 Connection :		E/D Control
1.15 Start-up Time :	$t_{str}$	10mS max
1.16 Standby Current :	$T_{STD}$	10uA max
1.17 RMS Phase Jitter :	$\phi_J$	1.0pS max (Integrated from 12KHz to 20MHz)
1.18 Aging :		Less than ±3 ppm/Year
1.19 Insulation Resistance :		500MΩ (DC100±10V)min
1.20 Output Waveform :		Refer to fig.1
1.21 Test Circuit :		Refer to fig.2

## Standard atmospheric conditions

Unless otherwise specified, the standard range of atmospheric conditions for making measurement and tests are as follow:

Ambient temperature : 25±3°C

Relative humidity : 40%~70%

CHIP SUN TECHNOLOGY CO., LTD		
DESCRIPTION	OSC-SMD3225 10.000MHz ±25ppm 3.3V	Page:
DATE	2023-03-17	3 / 11

## 2. Output Waveform

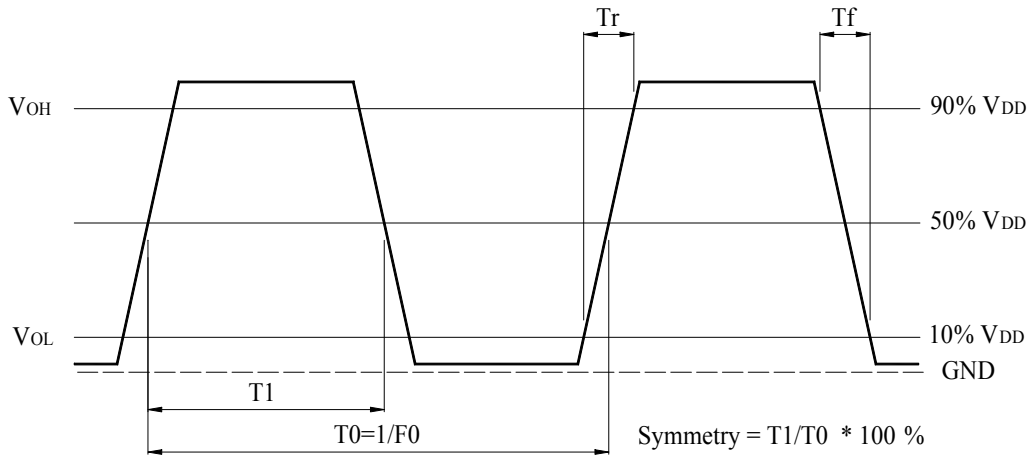

## 3. Test circuit

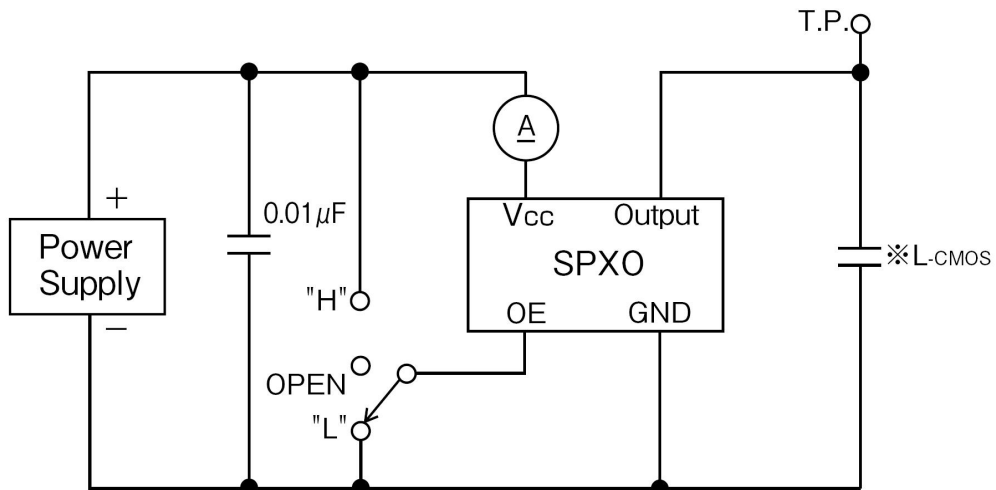

※L-CMOS: Total Fixture and Probe Capacitance

### CHIP SUN TECHNOLOGY CO., LTD

<b>DESCRIPTION</b>	OSC-SMD3225 10.000MHz $\pm 25\text{ppm}$ 3.3V	Page:
<b>DATE</b>	2023-03-17	4 / 11

## 4. FXO321S MARKING & DIMENSIONS

(UNIT: mm)

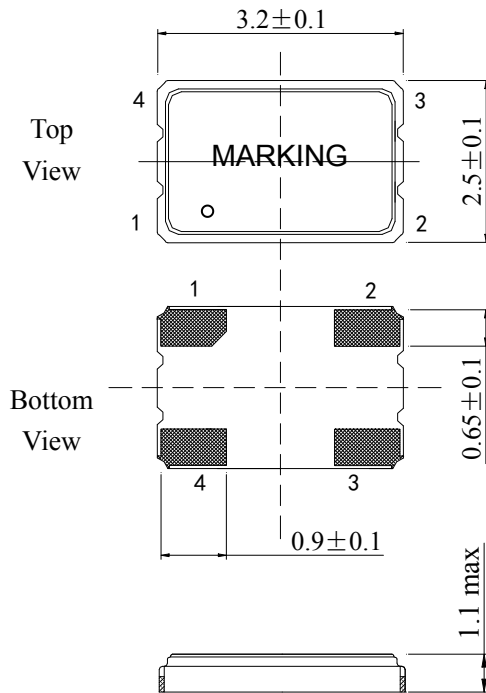

Pin	Connection
1	E/D
2	GND
3	Output
4	+V <sub>DD</sub>

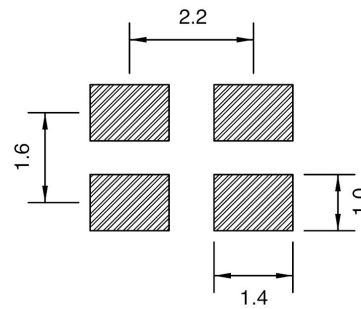

Recommended land Pattern

### Reference drawing

Base:	Alumina Ceramic (Al <sub>2</sub> O <sub>3</sub> ) Metallized Pad: W Ni Plating Au Plating
Cap:	Fe-Ni
(3) Crystal Enclosure Seal:	Seal Seam
(4) Crystal Blank	Rectangular At-Cut Quartz Crystal Blank
(5) Adhesive	Silver Conductive Polyimide Resin
(6) Electrode	Ag
(7) PAD	Alumina Ceramic (W. Ni. Au)

### E/D: Enable/Disable Function

Pin 1# (E/D control)	Pin 3# (output)
Open (NC)	Active
High "1" (V <sub>IH</sub> ≥ 70%V <sub>DD</sub> )	Active
Low "0" (V <sub>IH</sub> ≤ 30%V <sub>DD</sub> )	High impedance
<b>Disabled conditions:</b> <ul style="list-style-type: none"> <li>internal oscillator active</li> <li>output disabled, high impedance</li> </ul>	
<b>Enable condition:</b> <ul style="list-style-type: none"> <li>pull the E/D pin to 'H' if the oscillator should always be enabled</li> </ul>	

### CHIP SUN TECHNOLOGY CO., LTD

DESCRIPTION	OSC-SMD3225 10.000MHz ±25ppm 3.3V	Page:
DATE	2023-03-17	5 / 11

## 5. FXO321S EMBOSS CARRIER TAPE & REEL

### a.) Dimensions of Carrier Tape

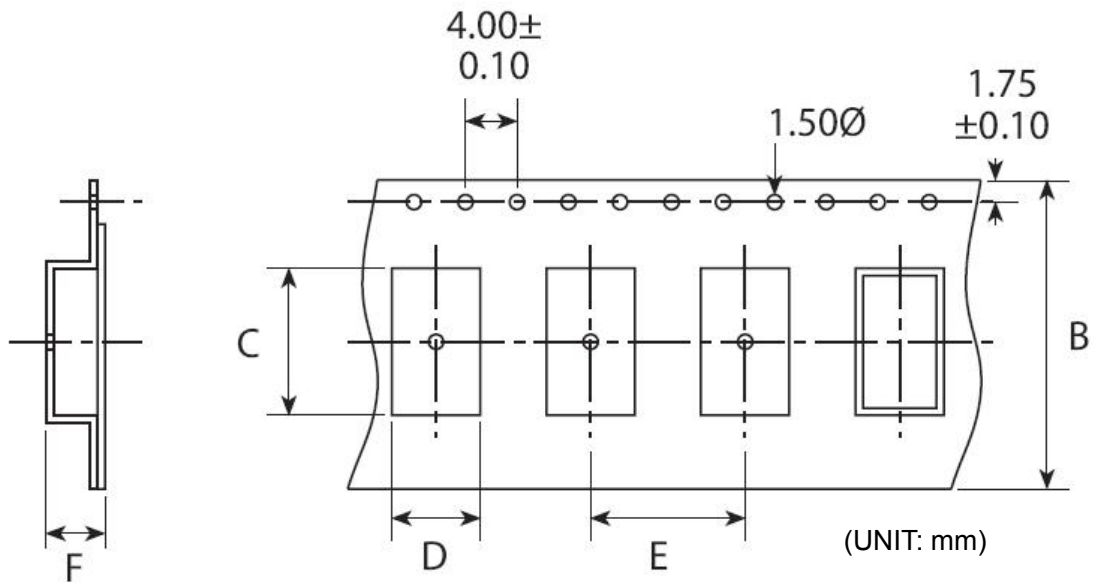

	A	B	C	D	E	F	G
OSC-SMD3225	180±2.0	8.0±0.2	3.50±0.10	2.80±0.10	4.0±0.1	1.4±0.1	60.5±1.0

### b.) Dimensions of Reel

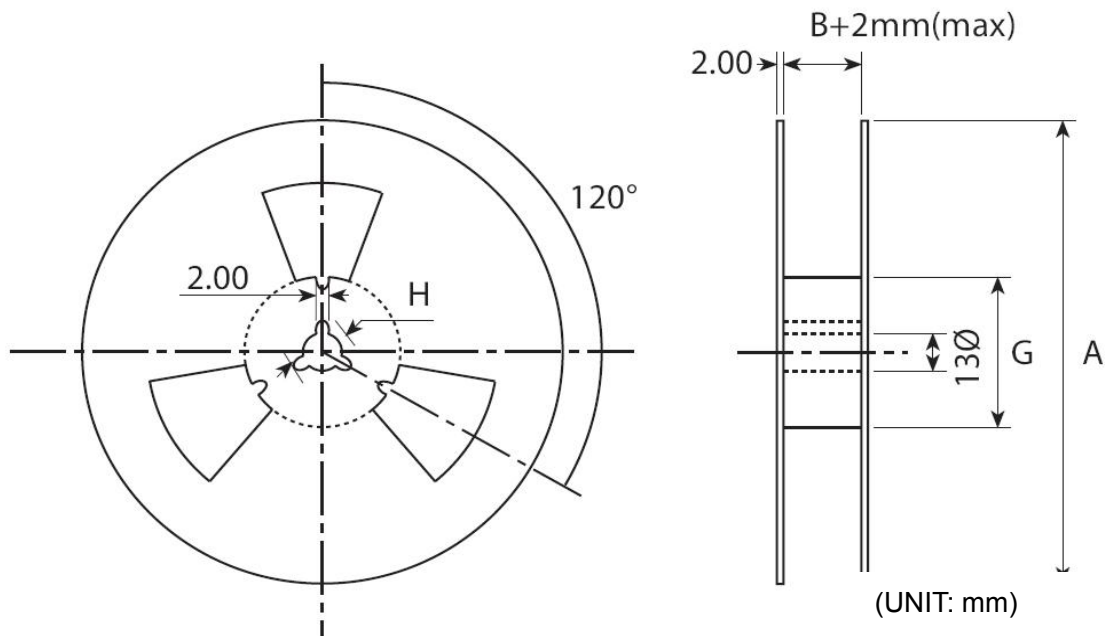

### CHIP SUN TECHNOLOGY CO., LTD

DESCRIPTION

OSC-SMD3225 10.000MHz ±25ppm 3.3V

Page:

DATE

2023-03-17

6 / 11

c.) Storage condition

Temperature: +40deg.C Max.

Relative Humidity: 80% Max.

d.) Standard packing quantity

3,000PCS / REEL

e.) Material of the tape

Tape	Material
Carrier tape	A – PET
Top tape	Polyester

f.) Label contents

.The type of product

.Our specification No.

.Your Part No.

.Lot No.

.Nominal Frequency

.Quantity

.Our Company Name

Sticks label for every reel.

PART NUMBER	
Lot. NO:	
HOLDER TYPE	
FREQUENCY	
REMAKS	
QUANTITY	
<b>CHIP SUN TECHNOLOGY CO., LTD</b>	

**CHIP SUN TECHNOLOGY CO., LTD**

<b>DESCRIPTION</b>	OSC-SMD3225 10.000MHz $\pm$ 25ppm 3.3V	Page:
<b>DATE</b>	2023-03-17	7 / 11

g.) Taping dimension

Leader	Cover-tape	The length of cover-tape in the leader is more than 400 mm including empty embossed area.
	Carrier-tape	After all products were packaged, must remain more than twenty pieces or 400 mm empty area, which should be sealed by cover-tape.
Terminal	Cover-tape	The tip of cover-tape shall be fixed temporary by paper tape and roll around the core of reel one round.
	Carrier-tape	The empty embossed area which are sealed by top cover-tape must remain more the 40 mm.

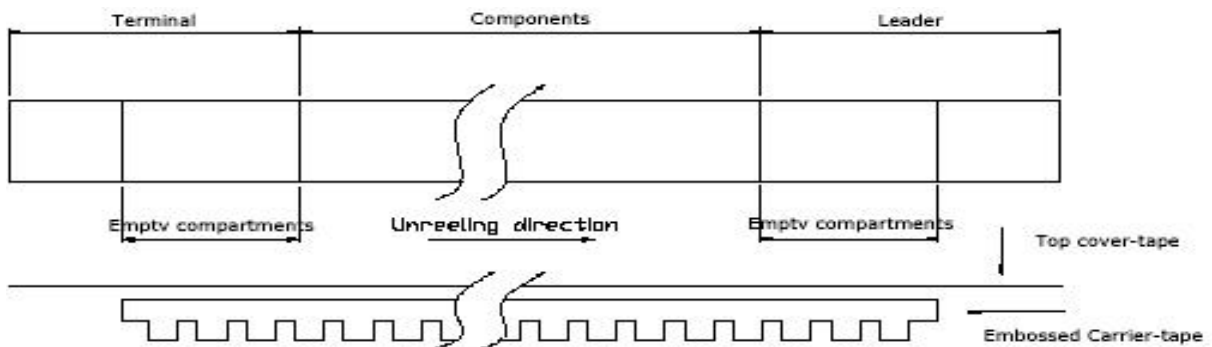

h.) Joint of tape

The carrier-tape and top cover-tape should not be jointed.

i.) Release strength of cover tape

It has to between 0.1N to 0.7N under following condition.

Pulling direction 165° to 180°

Speed 300mm/min.

Otherwise unless specified.

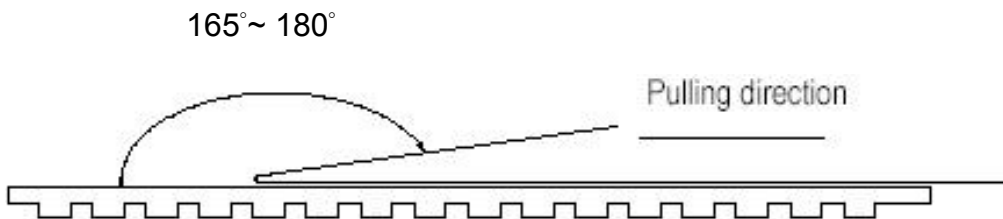

Other standards shall be based on JIS C 0806-1990.

CHIP SUN TECHNOLOGY CO., LTD		
DESCRIPTION	OSC-SMD3225 10.000MHz ±25ppm 3.3V	Page:
DATE	2023-03-17	8 / 11



6. Mechanical Endurance: Provided that measurement shall be carried out after letting it alone in the room temperature for 1 hour.

	Item	Conditions	Specifications
6.1	Drop	Should be satisfied after dropping three times from the height of 100 cm onto hard wooden board of thickness more than 30mm.	The parameters of table 3 must be satisfied
6.2	Vibration	Should be satisfied after supplying following (1)Vibration Frequency: 10~55Hz (2)Cycle: 1 to 2 Min. (3)Full Cycle: 0.8mm P-P. (4)Direction: X.Y.Z (5)Time: 2 Hours / Each Direction	The parameters of table 3 must be satisfied
6.3	Substrate Bending	Mount the specimen on substrate. Apply the following pressure Direction: see Fig -1 Speed: 0.5 mm/sec Hours: 5 ± 1 sec Amount of substrate: 3 mm Max.	The parameters of table 3 must be satisfied
6.4	Adhesion	Mount the specimen on substrate. Apply the following pressure Direction: see Fig -2 Weight: 10N Hours: 10 ± 1 sec	The parameters of table 3 must be satisfied
6.5	Body strength	Mount the specimen on substrate. Apply the following pressure Direction: see Fig -3 Weight: 10N Hours: 10 ± 1 sec	The parameters of table 3 must be satisfied

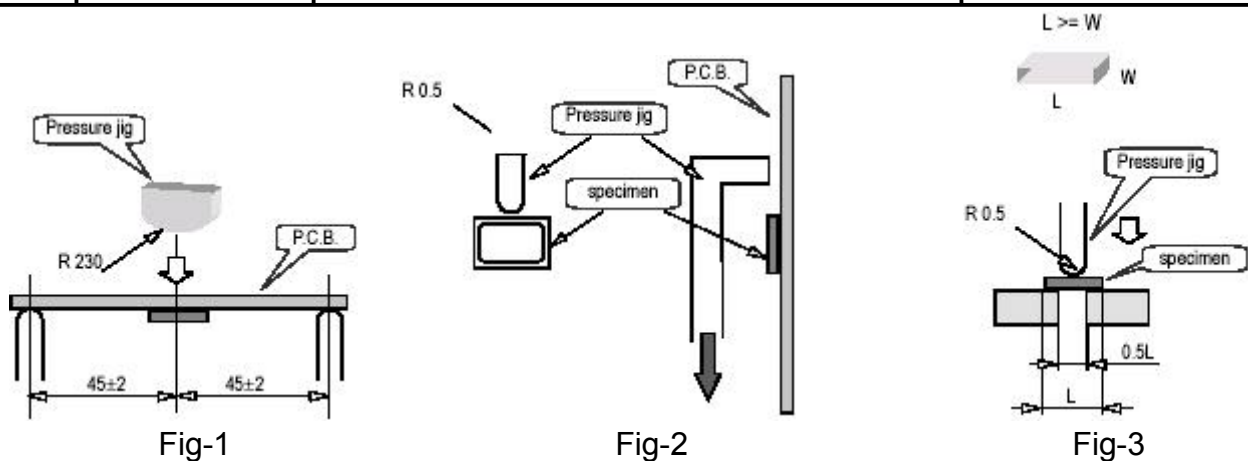

**CHIP SUN TECHNOLOGY CO., LTD**

<b>DESCRIPTION</b>	OSC-SMD3225 10.000MHz ±25ppm 3.3V	Page:
<b>DATE</b>	2023-03-17	9 / 11

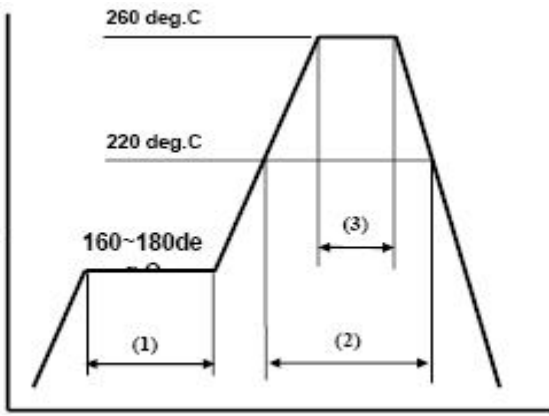
6.6	Seal	Less than $2.0 \times 10^{-9}$ Pa.m <sup>3</sup> /sec by Helium leak detector. Also, no serial bubble is observed by Fluorinate tests.													
6.7	Solder ability	3 sec Dip in 235°C±5°C solder. (Use ROSIN type flux for solder.)	More than 90% of lead shall be covered by new solder.												
6.8	Resistance to Soldering Heat	<p>Run in Reflow Reflow soldering shall be allowed Only two(2) time.</p> <p style="text-align: center;"><b>Available for Lead Free Soldering</b></p>  <table border="1" data-bbox="518 1209 1069 1332"> <tr> <td>(1)</td> <td>Preheat</td> <td>160~180 deg.C</td> <td>120sec.</td> </tr> <tr> <td>(2)</td> <td>Primary heat</td> <td>220 deg.C</td> <td>60sec.</td> </tr> <tr> <td>(3)</td> <td>Peak</td> <td>260 deg.C</td> <td>10sec. Max.</td> </tr> </table> <p>The parameters of table 3 must be satisfied</p>		(1)	Preheat	160~180 deg.C	120sec.	(2)	Primary heat	220 deg.C	60sec.	(3)	Peak	260 deg.C	10sec. Max.
(1)	Preheat	160~180 deg.C	120sec.												
(2)	Primary heat	220 deg.C	60sec.												
(3)	Peak	260 deg.C	10sec. Max.												

<b>CHIP SUN TECHNOLOGY CO., LTD</b>		
<b>DESCRIPTION</b>	OSC-SMD3225 10.000MHz ±25ppm 3.3V	Page:
<b>DATE</b>	2023-03-17	10 / 11

7. Environmental Endurance: Provided that measurement shall be carried out after letting it alone in the room temperature for 1 hour.

	Item	Conditions	Specifications
7.1	Humidity	Should be satisfied after letting it alone at $+60^{\circ}\text{C}\pm 2^{\circ}\text{C}$ in humidity of 90%~95% for 500 hours.	The parameters of table 1 must be satisfied. No physical damage.
7.2	Storage in Low Temperature	Should be satisfied after letting it alone at $-40^{\circ}\text{C}\pm 2^{\circ}\text{C}$ for 500 hours.	The parameters of table 1 must be satisfied. No physical damage.
7.3	Storage in High Temperature	Should be satisfied after letting it alone at $+85^{\circ}\text{C}\pm 2^{\circ}\text{C}$ for 500 hours.	The parameters of table 1 must be satisfied. No physical damage.
7.4	Temperature Cycle	Should be satisfied after supplying the following temperature cycle ( 100 cycles). (Refer to Fig-4). Temperature shift from low to high, high to low shall be done in $1^{\circ}\text{C}/\text{min}$ .	The parameters of table 1 must be satisfied. No physical damage.

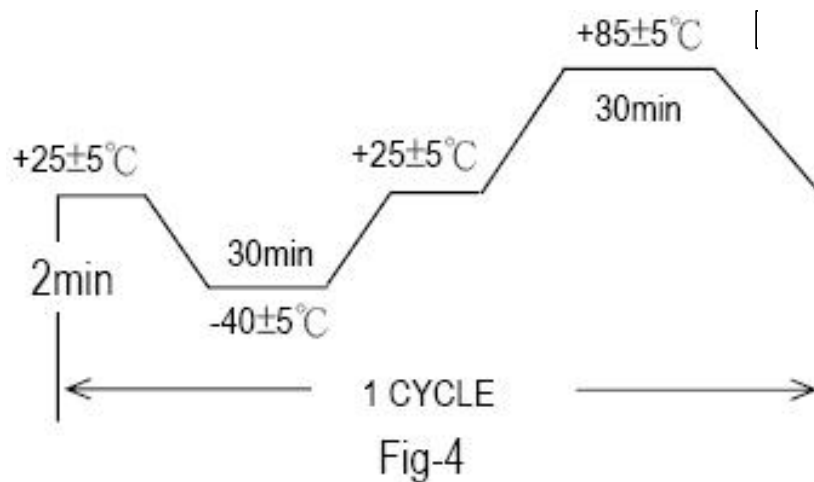

CHIP SUN TECHNOLOGY CO., LTD		
DESCRIPTION	OSC-SMD3225 10.000MHz $\pm 25\text{ppm}$ 3.3V	Page:
DATE	2023-03-17	11 / 11