

■ Features

- Ideally suited for automatic insertion
- For Switching and AF Amplifier Applications

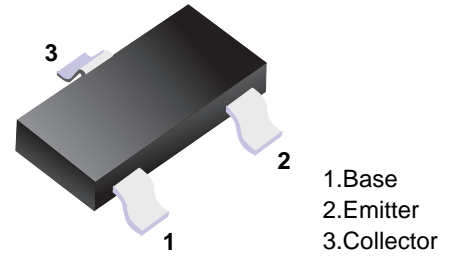

■ Simplified outline(SOT-23)

■ Absolute Maximum Ratings Ta = 25°C

Parameter	Symbol	BC856	BC857	BC858	Unit
Collector - Base Voltage	V _{CBO}	-80	-50	-30	V
Collector - Emitter Voltage	V _{CEO}	-65	-45	-30	
Emitter - Base Voltage	V _{EBO}	-5			
Collector Current - Continuous	I _C	-100			mA
Collector Power Dissipation	P _C	200			mW
Junction Temperature	T _J	150			°C
Storage Temperature range	T _{stg}	-55 to 150			

■ Electrical Characteristics Ta = 25°C

Parameter	Symbol	Test Conditions	Min	Typ	Max	Unit
Collector- base breakdown voltage	BC856	$I_C = -100 \mu A, I_E = 0$	-80			V
	BC857		-50			
	BC858		-30			
Collector- emitter breakdown voltage	BC856	$I_C = -1mA, I_B = 0$	-65			
	BC857		-45			
	BC858		-30			
Emitter - base breakdown voltage	V_{EBO}	$I_E = -100 \mu A, I_C = 0$	-5			
Collector-base cut-off current	BC856	I_{CBO}	$V_{CB} = -70 V, I_E = 0$			-100 nA
	BC857		$V_{CB} = -45 V, I_E = 0$			
	BC858		$V_{CB} = -25 V, I_E = 0$			
Collector- emitter cut-off current	BC856	I_{CEO}	$V_{CE} = -55 V, I_E = 0$			-1 uA
	BC857		$V_{CE} = -40 V, I_E = 0$			
	BC858		$V_{CE} = -25 V, I_E = 0$			
Emitter cut-off current	I_{EBO}	$V_{EB} = -5V, I_C = 0$			-100 nA	
Collector-emitter saturation voltage	$V_{CE(sat)}$	$I_C = -100 mA, I_B = -5mA$			-0.5	V
Base - emitter saturation voltage	$V_{BE(sat)}$	$I_C = -100 mA, I_B = -5mA$			-1.1	
DC current gain	BC856A,857A,858A	h_{FE}	$V_{CE} = -5V, I_C = -2mA$	125		250
	BC856B,857B,858B			220		475
	BC856C,857C,858C			420		800
Collector output capacitance	C_{ob}	$V_{CB} = -10V, f = 1MHz$			4.5	pF
Transition frequency	f_T	$V_{CE} = -5V, I_C = -10mA, f = 100MHz$	100			MHz

■ Classification of h_{FE}

Type	BC856A	BC856B	BC856C	BC857A	BC857B	BC857C	BC858A	BC858B	BC858C
Range	125-250	220-475	420-800	125-250	220-475	420-800	125-250	220-475	420-800
Marking	3A	3B	3C	3E	3F	3G	3J	3K	3L

■ Typical Characteristics

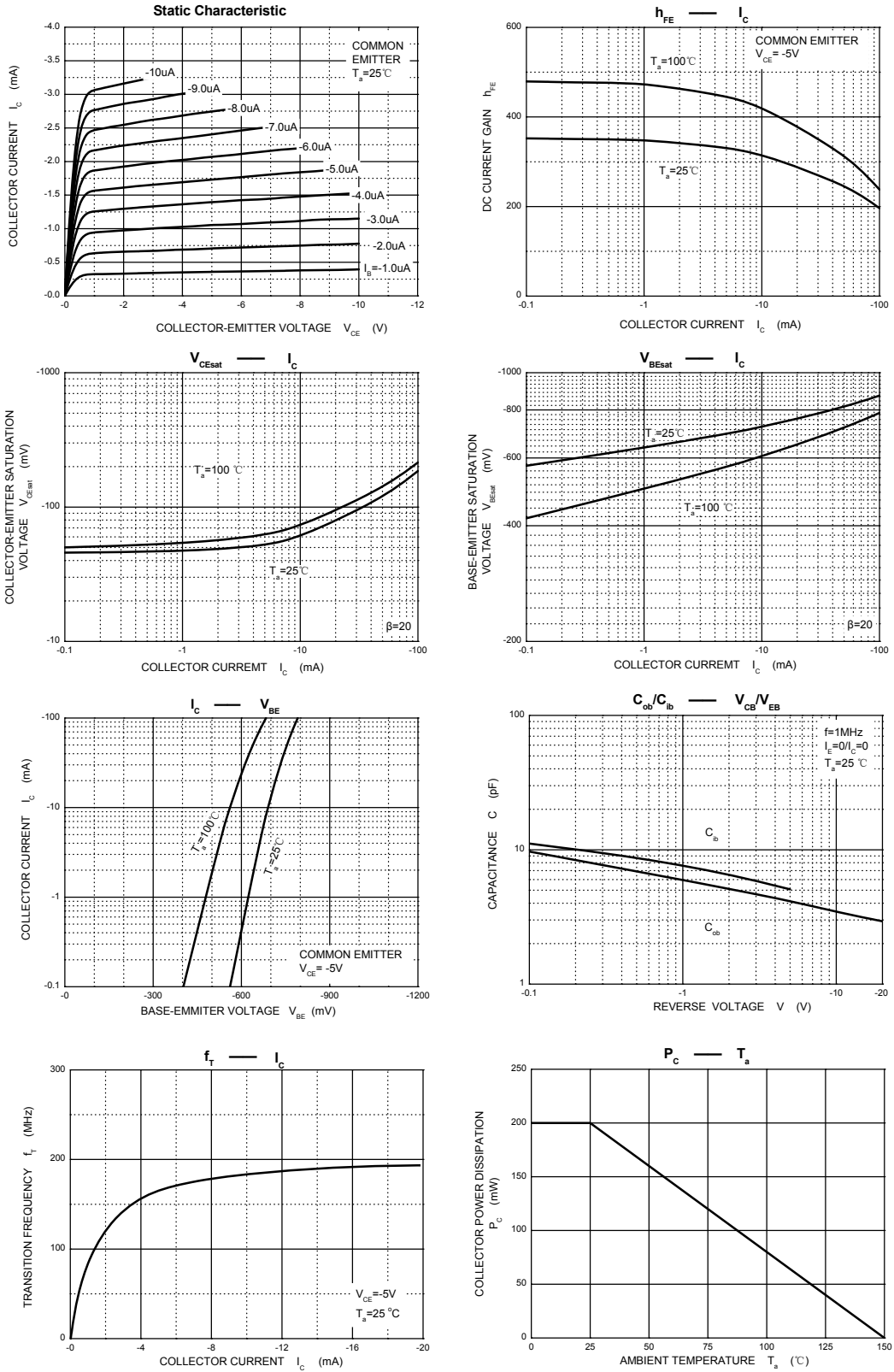

■ SOT-23

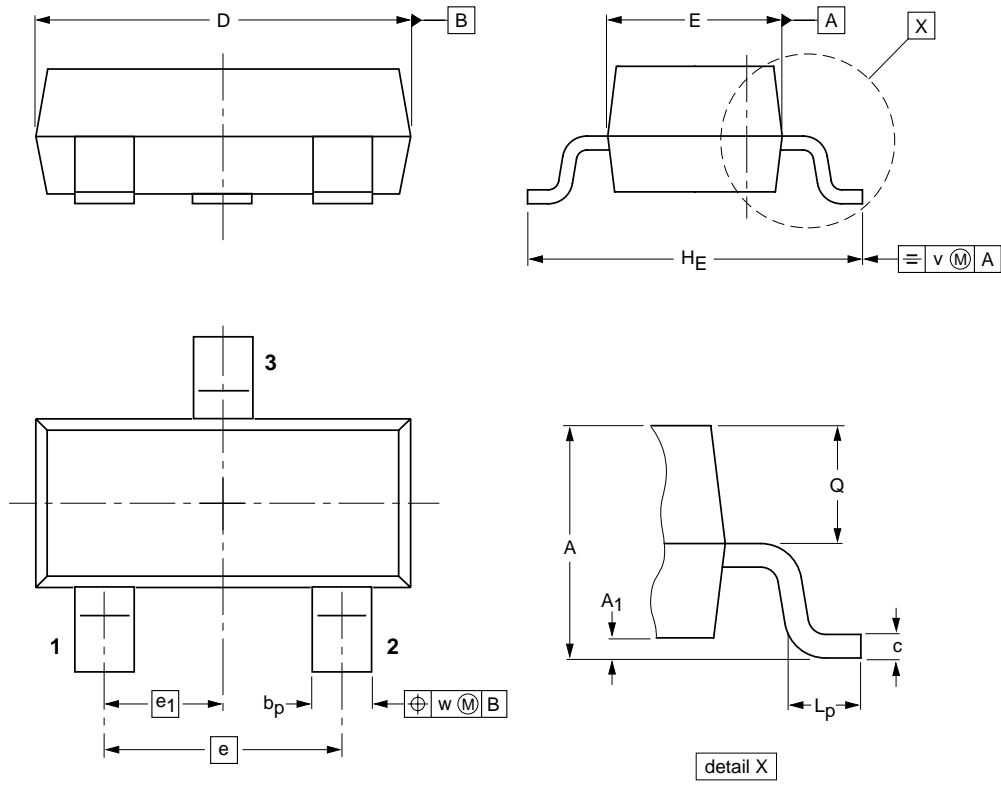

DIMENSIONS (mm are the original dimensions)

UNIT	A	A ₁ max.	b _p	c	D	E	e	e ₁	H _E	L _p	Q	v	w
mm	1.1 0.9	0.1	0.48 0.38	0.15 0.09	3.0 2.8	1.4 1.2	1.9	0.95	2.5 2.1	0.45 0.15	0.55 0.45	0.2	0.1