

NPN Medium Power Transistor BCP54/BCP55/BCP56

FEATURES

- For AF driver and output stages
- High collector current
- Low collector-emitter saturation voltage
- Complementary types: BCP51 ... BCP53 (PNP)

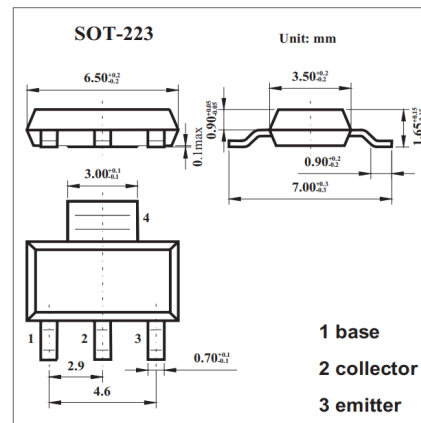

MAXIMUM RATINGS (T_a=25°C unless otherwise noted)

| Symbol | Parameter | BCP54 | BCP55 | BCP56 | Unit |
|------------------|--|----------|-------|-------|------|
| V _{CB0} | Collector-Base Voltage | 45 | 60 | 100 | V |
| V _{CEO} | Collector-Emitter Voltage | 45 | 60 | 80 | V |
| V _{EBO} | Emitter-Base Voltage | 5 | | | V |
| I _C | Collector Current -Continuous | 1 | | | A |
| P _C | Collector Power Dissipation | 1.5 | | | W |
| R _{θJA} | Thermal Resistance Junction to Ambient | 83.3 | | | °C/W |
| T _{stg} | Storage Temperature Range | -65~+150 | | | °C |

ELECTRICAL CHARACTERISTICS (T_a=25°C unless otherwise specified)

| Parameter | Symbol | Test conditions | Min | Max | Unit |
|--------------------------------------|----------------------|---|-----|-----|------|
| Collector-base breakdown voltage | BCP54 | V _{(BR)CBO} I _C = 0.1mA, I _E =0 | 45 | | V |
| | BCP55 | | 60 | | |
| | BCP56 | | 100 | | |
| Collector-emitter breakdown voltage | BCP54 | V _{(BR)CEO} I _C = 10mA, I _B =0 | 45 | | V |
| | BCP55 | | 60 | | |
| | BCP56 | | 80 | | |
| Base-emitter breakdown voltage | V _{(BR)EBO} | I _E = 10μA, I _C =0 | 5 | | V |
| Collector cut-off current | I _{CBO} | V _{CB} = 30 V, I _E =0 | | 100 | nA |
| DC current gain | h _{FE(1)} | V _{CE} = 2V, I _C =5mA | 25 | | |
| | h _{FE(2)} | V _{CE} = 2V, I _C =150m A | 63 | 250 | |
| | h _{FE(3)} | V _{CE} = 2V, I _C =500m A | 25 | | |
| Collector-emitter saturation voltage | V _{CE(sat)} | I _C =500mA, I _B =50mA | | 0.5 | V |
| Base-emitter voltage | V _{BE} | V _{CE} =2V, I _C =500m A | | 1 | V |
| Transition frequency | f _T | V _{CE} =10V, I _C =50mA, f=100MHz | 100 | | MHz |

CLASSIFICATION OF h_{FE(2)}

| | | |
|-------|------------------------------|------------------------------|
| Rank | BCP54-10, BCP55-10, BCP56-10 | BCP54-16, BCP55-16, BCP56-16 |
| Range | 63-160 | 100-250 |

NPN Medium Power Transistor BCP54/BCP55/BCP56

Typical Characteristics

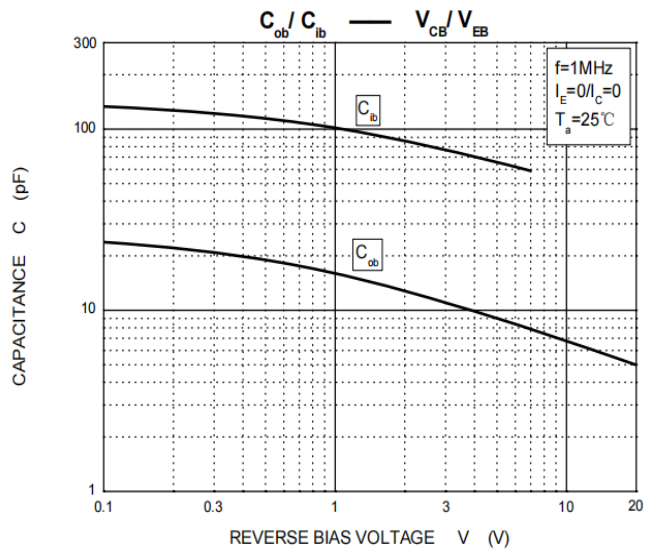
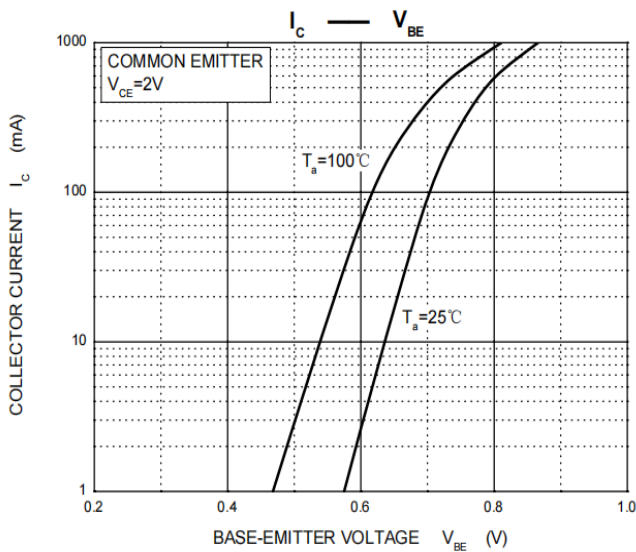
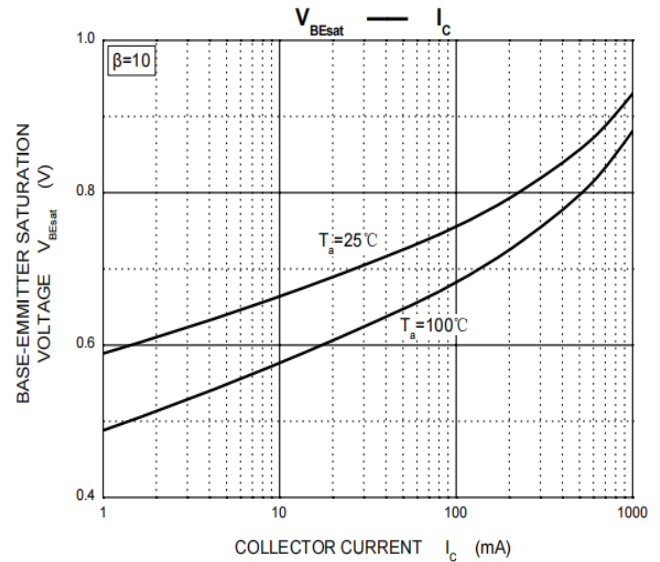
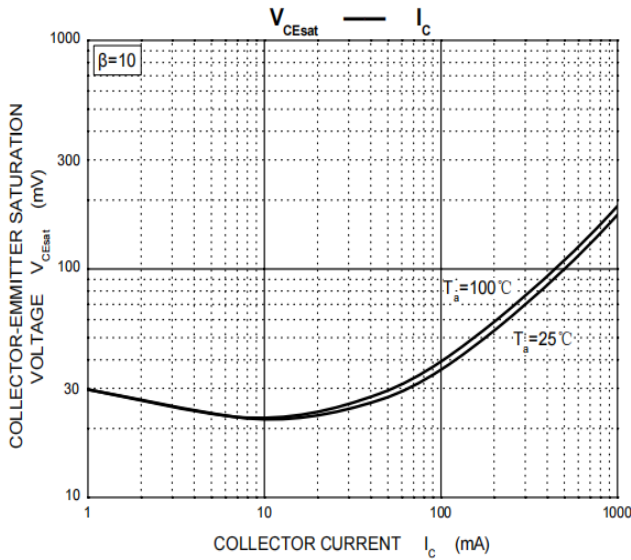
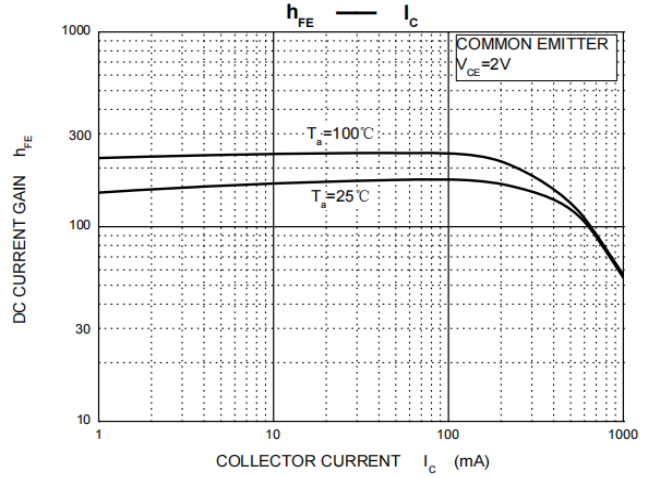
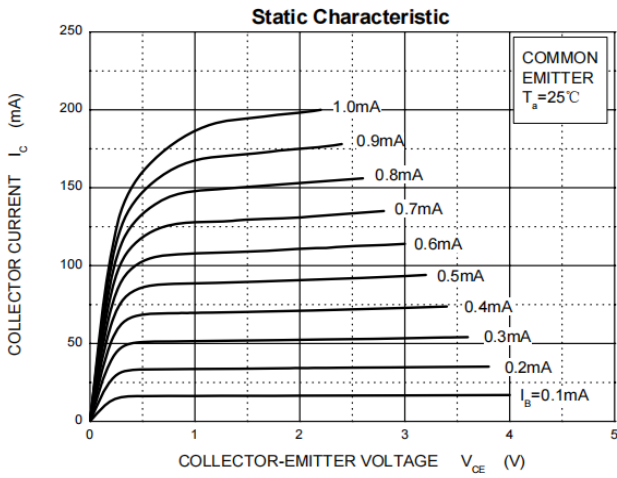

NPN Medium Power Transistor BCP54/BCP55/BCP56

