

1.Features

- Transient Voltage Suppression (TVS) protection of one line
- Max. peak pulse power: $P_{pp}=890\text{ W}$
- Low clamping voltage: $V_{CL}=19\text{V}$
- Low leakage current: $I_{RM}=300\text{nA}$
- ESD protection up to 30kV
- IEC 61000-4-2; level 4 (ESD)
- IEC 61000-4-5 (surge); $I_{pp}=47\text{ A}$
- AEC-Q101 qualified

2.Applications

- Computers and peripherals
- Audio and video equipment
- Cellular handsets and accessories
- Communication systems
- Portable electronics
- Medical and industrial equipment

3.Mechanical Data

- SOD323 package
- Molding compound flammability rating: UL94V-0
- Packaging: Tape and Reel
- RoHS/WEEE Compliant

4.Pinning information

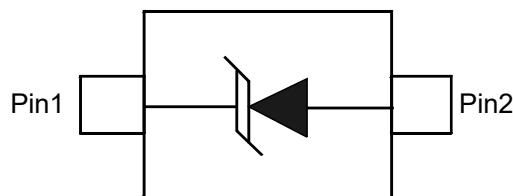

SOD-323



5. Quick reference data

$T_{amb}=25^{\circ}\text{C}$ unless otherwise specified.

Parameter	Symbol	Conditions	Min	Typ	Max	Units
reverse standoff voltage	V_{RWM}				5	V
diode capacitance	C_d	$V_R=0\text{V}$, $f=1\text{MHz}$		480	530	pF

6. Limiting values

In accordance with the Absolute Maximum Rating System (IEC 60134).

Parameter	Symbol	Conditions	Min	Typ	Max	Units
peak pulse power	P_{PP}	$t_p=8/20\mu\text{s}$ ①②			890	W
peak pulse current	I_{PP}	$t_p=8/20\mu\text{s}$ ①②			47	A
total power dissipation	P_{tot}	$T_{amb} \leq 25^{\circ}\text{C}$ ③			360	mW
		④			500	mW
junction temperature	T_J				150	$^{\circ}\text{C}$
ambient temperature	T_{amb}		-55		150	$^{\circ}\text{C}$
storage temperature	T_{STG}		-65		150	$^{\circ}\text{C}$

Notes:

- ① Non-repetitive current pulse 8/20 μs exponential decay waveform according to IEC 61000-4-5.
- ② Soldering point of cathode tab.
- ③ Device mounted on an FR4 Printed-Circuit Board (PCB), single-sided copper, tin-plated and standard footprint.
- ④ Device mounted on an FR4 PCB, single-sided copper, tin-plated, mounting pad for cathode 1 cm^2 .



7.ESD maximum ratings

$T_{amb}=25^{\circ}\text{C}$ unless otherwise specified.

Parameter	Symbol	Conditions	Min	Typ	Max	Units
electrostatic discharge voltage	V_{ESD}	IEC 61000-4-2 (contact discharge) ①			30	kV
		machine model			400	V

Notes:

① Device stressed with ten non-repetitive ESD pulses.

8.ESD standards compliance

Parameter	Conditions
IEC 61000-4-2; level 4 (ESD)	> 15 kV (air); > 8 kV (contact)
MIL-STD-883; class 3 (human body model)	> 4 kV



9. Electrical Characteristic (T_A=25°C unless otherwise noted)

Parameter	Symbol	Conditions	Min	Typ	Max	Units
reverse standoff voltage	V _{RWM}				5	V
reverse leakage current	I _{RM}	V _{RWM} =5V		0.3	4	μA
breakdown voltage	V _{BR}	I _R =5mA	6.2	6.8	7.3	V
diode capacitance	C _d	V _R =0V, f=1MHz		480	530	pF
clamping voltage	V _{CL}	I _{pp} =47A ①			19	V
		I _{pp} =25A			13.5	V
		I _{pp} =5A			9.8	V
differential resistance	r _{dif}	I _R =5mA		2	100	Ω

Notes:

① Non-repetitive current pulse 8/20 μs exponential decay waveform according to IEC 61000-4-5.



10. Typical characteristic

<p>Figure 1: 8/20 μs pulse waveform according to IEC 61000-4-5</p>	<p>Figure 2: ESD pulse waveform according to IEC 61000-4-2</p>
<p>Figure 3: Peak pulse power as a function of exponential pulseduration; typical values</p>	<p>Figure 4: Relative variation of peak pulse power as a function of junction temperature; typical values</p>
<p>Figure 5: unclamped +8 kV ESD pulse waveform (IEC 61000-4-2 network)</p>	<p>Figure 6: clamped +8 kV ESD pulse waveform (IEC 61000-4-2 network)</p>



11.SOD-323 Package Outline Dimensions

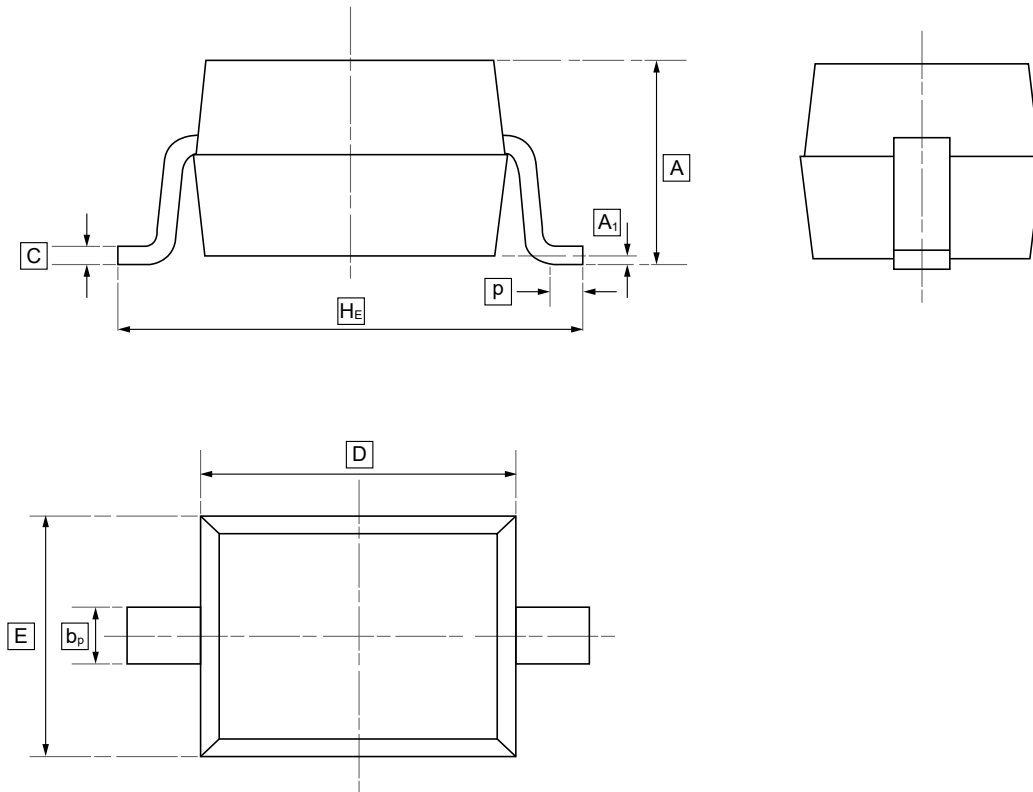

DIMENSIONS (mm are the original dimensions)

Symbol	A	bp	C	D	E	HE	A ₁	P
Min	0.90	0.25	0.10	1.60	1.15	2.30	0.01	0.20
Max	1.20	0.40	0.15	1.80	1.35	2.80	0.10	0.50



12. Ordering information



Order Code	Package	Base QTY	Delivery Mode
UMW PESD5V0S1UA	SOD-323	3000	Tape and reel



13.Disclaimer

UMW reserves the right to make changes to all products, specifications. Customers should obtain the latest version of product documentation and verify the completeness and currency of the information before placing an order.

When applying our products, please do not exceed the maximum rated values, as this may affect the reliability of the entire system. Under certain conditions, any semiconductor product may experience faults or failures. Buyers are responsible for adhering to safety standards and implementing safety measures during system design, prototyping, and manufacturing when using our products to prevent potential failure risks that could lead to personal injury or property damage.

Unless explicitly stated in writing, UMW products are not intended for use in medical, life-saving, or life-sustaining applications, nor for any other applications where product failure could result in personal injury or death. If customers use or sell the product for such applications without explicit authorization, they assume all associated risks.

When reselling, applying, or exporting, please comply with export control laws and regulations of China, the United States, the United Kingdom, the European Union, and other relevant countries, regions, and international organizations.

This document and any actions by UMW do not grant any intellectual property rights, whether express or implied, by estoppel or otherwise. The product names and marks mentioned herein may be trademarks of their respective owners.