

Typical Performance

Wide input voltage, non-isolated regulated single-channel output, DC-DC module power supply

- Efficiency up to 96%
- No-load input current as low as 0.3mA
- Operating temperature: -40°C~+85°C
- Sustainable short circuit protection
- Support negative output
- Pin compatibility with LM78xx series
- Support customization

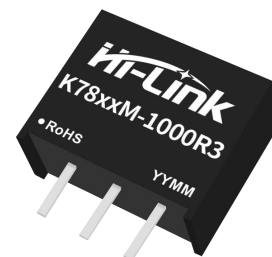

RoHS

The K78xxM-1000R3 series are high-efficiency switching regulators, an ideal replacement for the LM78xx series three-terminal linear regulators. They feature high efficiency, low losses, and require no external heatsink. These products are widely used in industrial control, power, instrumentation, and other industries.

Product Selection Table

| Product Model | Input voltage range (Vdc) | Output voltage/current | | Ripple and noise | Full load efficiency |
|----------------|-----------------------------|------------------------|--------------------------------|----------------------------|----------------------|
| | Nominal value (range value) | Output voltage (Vdc) | Output current (mA) (Max.Min.) | Full load (mVp-p) Typ/Max. | % Typ./Min.(Vin) |
| K7803M-1000R3 | 24 (6~36) | 3.3 | 1000 | 20/70 | 90/80 |
| K7805M-1000R3 | 24 (8~36) | 5 | 1000 | 20/70 | 93/85 |
| | 12 (8-27) | -5 | -500 | 20/70 | 85/81 |
| K7809M -1000R3 | 24 (13-36) | 9 | 1000 | 20/70 | 94/89 |
| K7812M-1000R3 | 24 (16-36) | 12 | 1000 | 20/70 | 95/92 |
| | 12 (8-20) | -12 | -300 | 20/70 | 88/87 |
| K7815M-1000R3 | 24 (20-36) | 15 | 1000 | 20/70 | 96/93 |
| | 12 (8-18) | -15 | -300 | 20/70 | 87/88 |

Note: 1. Due to space limitations, the above is only a typical product list. For products not listed, please contact our sales department.

2. When the input voltage exceeds 30VDC, a 22uF/50V electrolytic capacitor must be connected externally to the input terminal to prevent voltage spikes from damaging the module.

Test conditions: Unless otherwise specified, all parameters were measured at nominal input voltage, purely resistive rated load and 25°C room temperature.

Input Characteristics

| Items | Working conditions | Min. | Typ. | Max. | Unit. |
|--|--------------------|---------------------|------|------|-------|
| No-load input current (full load/no load) | Positive output | -- | 0.1 | 1.0 | mA |
| | Negative output | -- | 1 | 4 | |
| Reverse input | | Prohibit | | | mA |
| Input filter type (Isec.max) | | Capacitor filtering | | | VDC |
| Hot-swap | | No support | | | |

Output Characteristics

| Items | Working and testing conditions | | Mi | Typ. | Max. | Unit. |
|---------------------------------|--|-----------------|----|------|-------|-------|
| Output voltage accuracy | Full load, input voltage range | 3.3V output | -- | ±2 | ±4 | % |
| | | Other models | -- | ±1.5 | ±3 | % |
| Linear adjustment rate | Full load, input voltage range | | -- | ±0.2 | ±0.4 | % |
| Load regulation | 10%~100% load | Positive output | -- | ±0.4 | ±0.6 | % |
| | | Negative output | -- | ±0.4 | ±0.8 | % |
| Ripple & Noise | Pure resistive load, 20MHz bandwidth, peak-to-peak, 20% - 100% load | | -- | 25 | 75 | mVp-p |
| Temperature drift coefficient | Operating temperature -40°C to +85°C | | -- | -- | ±0.03 | %/°C |
| Transient response deviation | Nominal input voltage, load step change of 25%-50%-25% and 50%-75%-50% | | -- | ±60 | ±200 | mVp-p |
| Transient recovery | | | -- | -- | 1 | ms |
| Output short circuit protection | Long-term short circuit, automatic recovery | | | | | - |

Note: ① The ripple and noise test method adopts the parallel line test method. For specific operation methods, please refer to the "Application Guide for Non-Isolated Module Power Supplies".

② At a load of less than 20%, the maximum ripple and noise of the 3.3V/5V output is 100mVp-p, and the maximum ripple and noise of the 9V/12V/15V output is 2%Vo.

General Characteristics

| Items | Working condition | Min. | Typ. | Max. | Unit. |
|---|---|--|------|------|-------|
| Operating temperature | Using the reference temperature derating curve | -40 | -- | +85 | °C |
| Storage temperature | | -55 | -- | +125 | |
| Temperature rise of the outer casing during | | -- | 25 | -- | |
| Storage humidity | No condensation | 5 | -- | 95 | %RH |
| Pin soldering temperature resistance | Solder joint distance from casing: 1.5mm, 10 seconds (Max.) | -- | -- | +260 | °C |
| Switching frequency | Full load, nominal voltage input | -- | 520 | -- | KHz |
| Shock | | 10-55Hz, 10G, 30 Min. along X, Y and Z | | | |

| | | | | | |
|-------------------------------|---|--------------------|----|----|------|
| Shell material | Black flame-retardant and heat-resistant plastic (UL94 V-0) | | | | |
| Package size | K78xx-1000R3 | 11.60x7.55x10.16mm | | | |
| Weight | 1.9g (Typ.) | | | | |
| Cooling method | Natural cooling | | | | |
| Minimum time between failures | MIL-HDBK-217F@25°C | 2000 | -- | -- | KHrs |

Note: For 9V/12V/15V positive output, when $V_{in} > 30V$, derating begins at 55°C and is reduced to 40%Io at 85°C.

Product Characteristic Curves



图 1



Typical Application Reference Circuit (Recommended Parameters)

1. Common Applications:

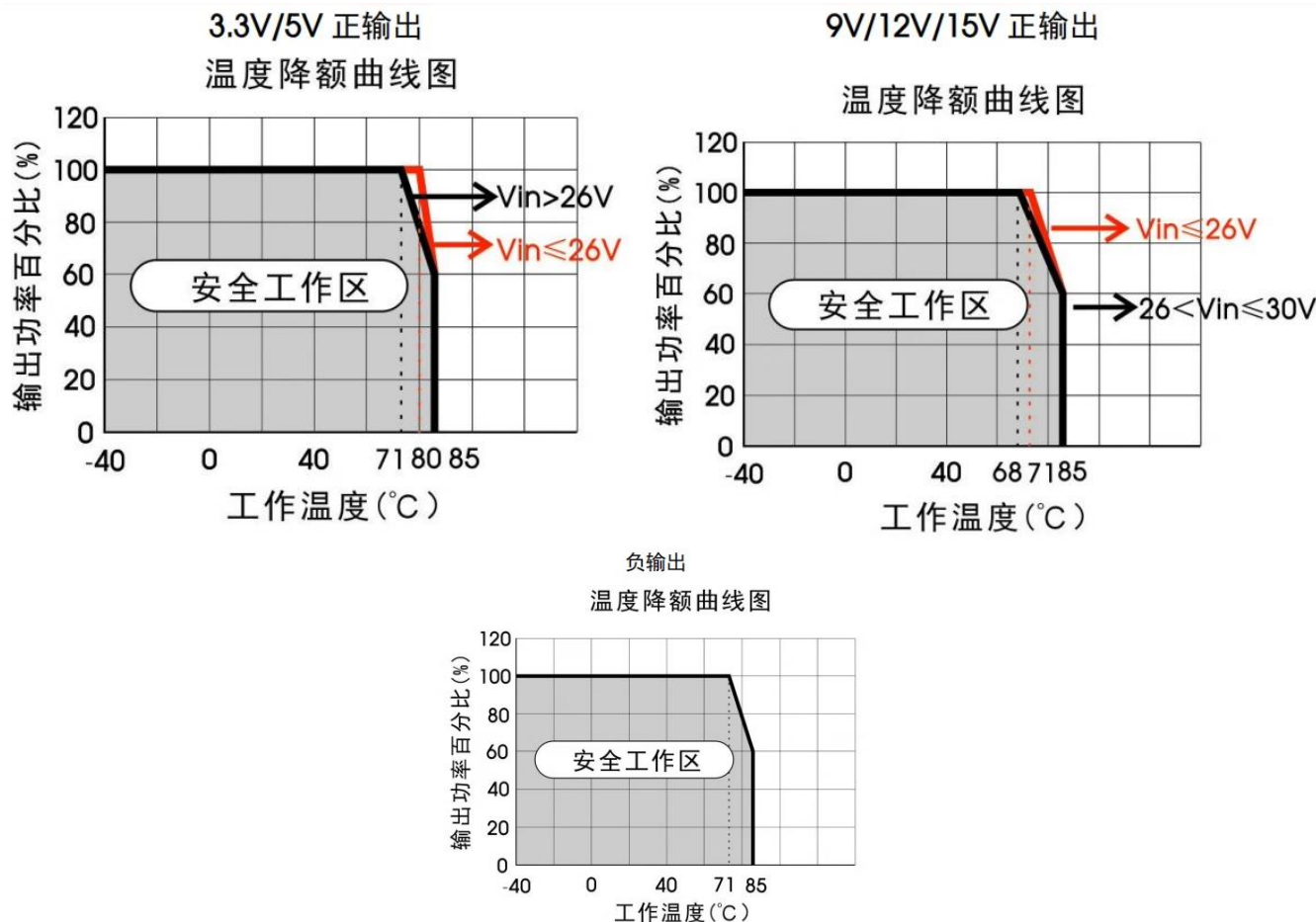
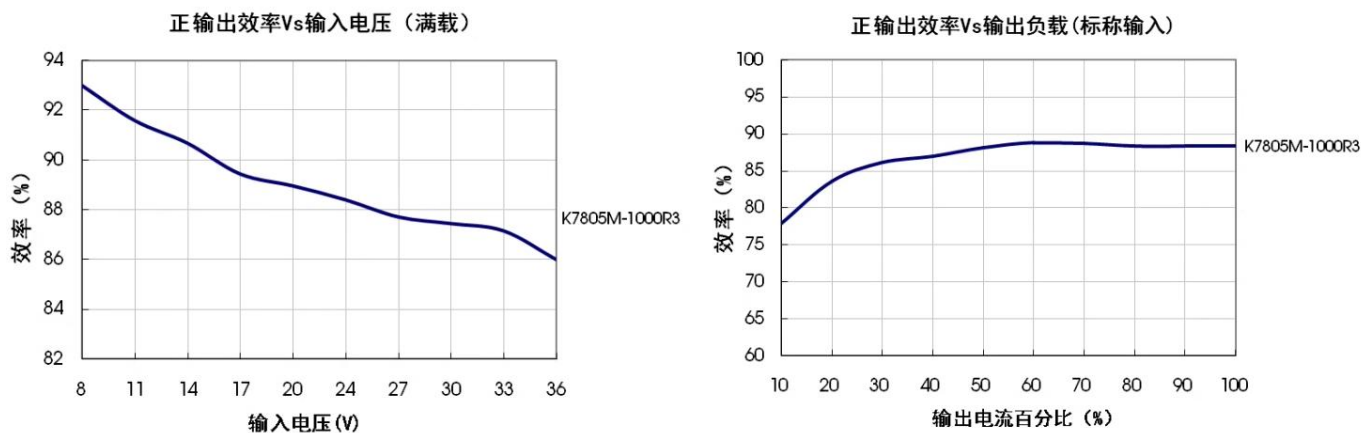

图1典型应用电路



| Model | C1/C3 (Ceramic capacitor) | C2/C4 (Ceramic capacitor) |
|---------------|------------------------------|------------------------------|
| K7803M-1000R3 | 10uF/50V | 22uF/10V |
| K7805M-1000R3 | | 22uF/10V |
| K7809M-1000R3 | | 22uF/16V |
| K7812M-1000R3 | | 22uF/25V |
| K7815M-1000R3 | | 22uF/25V |

Table 1

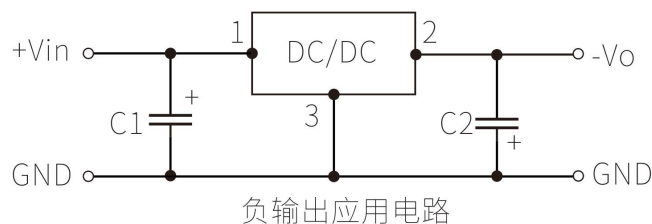
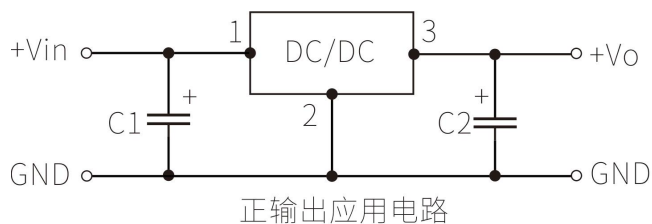
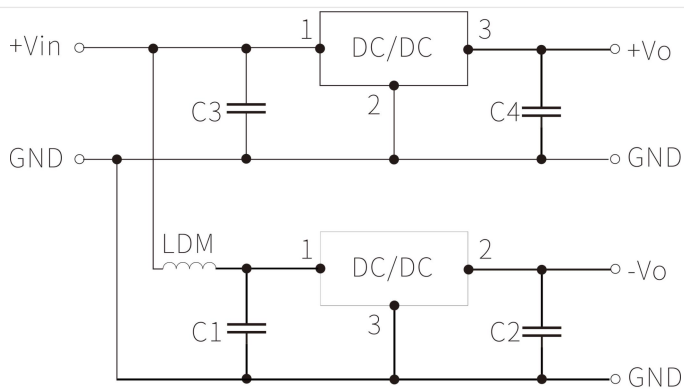
- Note: 1. Under normal circumstances, external capacitors C1 and C2 (C3 and C4) can be connected depending on the product's operating environment, and the capacitors should be positioned close to the product's pins;
2. The capacitance values of C1 and C2 (C3 and C4) are referenced in Table 1. They can be increased appropriately as needed, or low-ESR tantalum capacitors and electrolytic capacitors can be used;
3. When the product is used in the application circuit shown in Figure 2, it is recommended to add an inductor LDM to reduce mutual interference between products. The recommended value for LDM is 10μH;
4. This product does not support hot-swapping, and the outputs cannot be connected in parallel.

2. EMC Recommended Circuit

| | EMC 推荐电路图 | 参数 | | | | | | | | | | | | | | |
|----------|--------------|--|------|--------------|-----|---------|------|------|----|------------|------|-------|----------|------------|----|-----------|
| 正输出 | | <table border="1"> <tr> <td>FUSE</td> <td>依照客户实际输入电流选择</td> </tr> <tr> <td>MOV</td> <td>20D470K</td> </tr> <tr> <td>LDM1</td> <td>82μH</td> </tr> <tr> <td>C0</td> <td>680μF /50V</td> </tr> <tr> <td>LCM1</td> <td>4.7mH</td> </tr> <tr> <td>C1/C2</td> <td>4.7μF /50V</td> </tr> <tr> <td>C3</td> <td>参照表 1 参数</td> </tr> </table> | FUSE | 依照客户实际输入电流选择 | MOV | 20D470K | LDM1 | 82μH | C0 | 680μF /50V | LCM1 | 4.7mH | C1/C2 | 4.7μF /50V | C3 | 参照表 1 参数 |
| FUSE | 依照客户实际输入电流选择 | | | | | | | | | | | | | | | |
| MOV | 20D470K | | | | | | | | | | | | | | | |
| LDM1 | 82μH | | | | | | | | | | | | | | | |
| C0 | 680μF /50V | | | | | | | | | | | | | | | |
| LCM1 | 4.7mH | | | | | | | | | | | | | | | |
| C1/C2 | 4.7μF /50V | | | | | | | | | | | | | | | |
| C3 | 参照表 1 参数 | | | | | | | | | | | | | | | |
| 负输出 | | <table border="1"> <tr> <td>FUSE</td> <td>依照客户实际输入电流选择</td> </tr> <tr> <td>MOV</td> <td>20D470K</td> </tr> <tr> <td>LDM1</td> <td>82μH</td> </tr> <tr> <td>C0</td> <td>680μF /50V</td> </tr> <tr> <td>LCM1</td> <td>4.7mH</td> </tr> <tr> <td>C1/C3/C4</td> <td>4.7μF /50V</td> </tr> <tr> <td>C2</td> <td>10μF /50V</td> </tr> </table> | FUSE | 依照客户实际输入电流选择 | MOV | 20D470K | LDM1 | 82μH | C0 | 680μF /50V | LCM1 | 4.7mH | C1/C3/C4 | 4.7μF /50V | C2 | 10μF /50V |
| FUSE | 依照客户实际输入电流选择 | | | | | | | | | | | | | | | |
| MOV | 20D470K | | | | | | | | | | | | | | | |
| LDM1 | 82μH | | | | | | | | | | | | | | | |
| C0 | 680μF /50V | | | | | | | | | | | | | | | |
| LCM1 | 4.7mH | | | | | | | | | | | | | | | |
| C1/C3/C4 | 4.7μF /50V | | | | | | | | | | | | | | | |
| C2 | 10μF /50V | | | | | | | | | | | | | | | |

Product Dimensions and Pin Definitions, Recommended PCB Layout

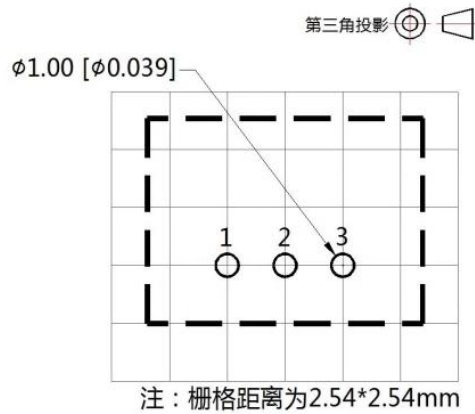
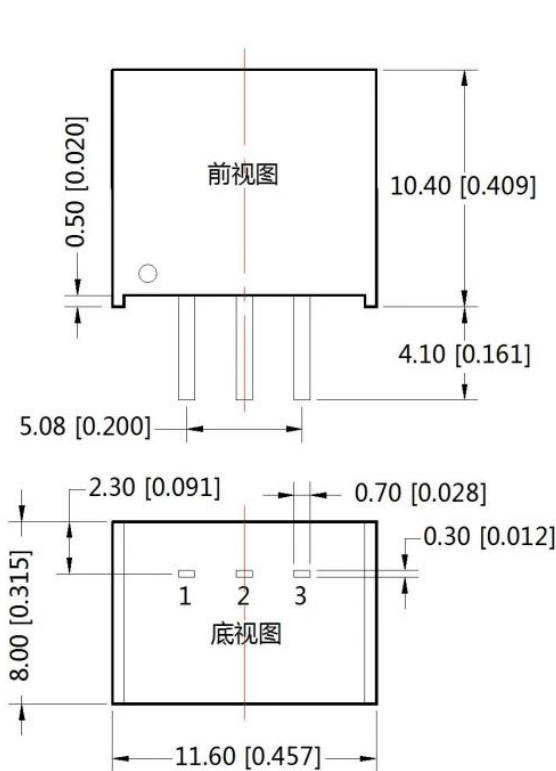

| 引脚方式 | | |
|------|-----|-----|
| 引脚 | 正输出 | 负输出 |
| 1 | Vin | Vin |
| 2 | GND | -Vo |
| 3 | +Vo | GND |

注：
尺寸单位：mm[inch]
端子截面公差： ± 0.10 [± 0.004]
未标注公差： ± 0.50 [± 0.020]

*Note: If the pin definitions of the power module do not match those in the selection manual, the markings on the actual product label shall prevail.

Package Description

| Model | L x W x H | |
|---------------|--------------------|---------------------------|
| K78xx-1000R3 | 11.60x9.00x17.50mm | 0.457 × 0.354 × 0.689inch |
| K78xx-1000R3L | 19.00x11.60x9.00mm | 0.748 × 0.457 × 0.354inch |

Product Application Precautions

1. Input Requirements: Ensure the output voltage fluctuation range of the power supply does not exceed the input requirements of the DC/DC module itself, and the output power of the input power supply must be greater than the output power of the DC/DC module;
2. The capacitance value of the external capacitor connected to the output terminal should not be too large, otherwise it may easily cause overcurrent or poor startup during module startup;
3. Maximum capacitive loads are tested under full load conditions within the input voltage range;
4. Unless otherwise specified, all specifications in this manual are measured at $T_a=25^\circ\text{C}$, humidity $<75\%\text{RH}$, nominal input voltage and rated output load;
5. All test methods for specifications in this manual are based on our company's standards;
6. We can provide product customization. Please contact our technical staff directly for details;
7. Product specification changes will not be notified separately.

Contact

Shenzhen Hi-Link Electronic Co., Ltd.

深圳市海凌科电子有限公司

Address: 17F, Building E, Xinghe WORLD, Minzhi Street, Longhua district, Shenzhen 518131

Telephone: 0755-23152658

Email: sales@hlktech.com

Website: www.hlktech.net