

The product using material and processing must conform to the "WL-PZ-001"HSF technical standard control requirements

A	PIN,NO	3	4	5	6	8
B	CODE					
B	Adapter cable (AWG)	22	22	22	24	24
B	Conductor diameter (mm)	1.0	1.0	1.0	0.8	0.8
B	Rated Current (A)	4	4	4	2	2
B	Rated Voltage (V)	250	250	60	30	30
C	Insulation Resistance (MΩ)	≥1000	≥1000	≥1000	≥1000	≥1000
C	Contact Resistance (mΩ)	≤10	≤10	≤10	≤10	≤10

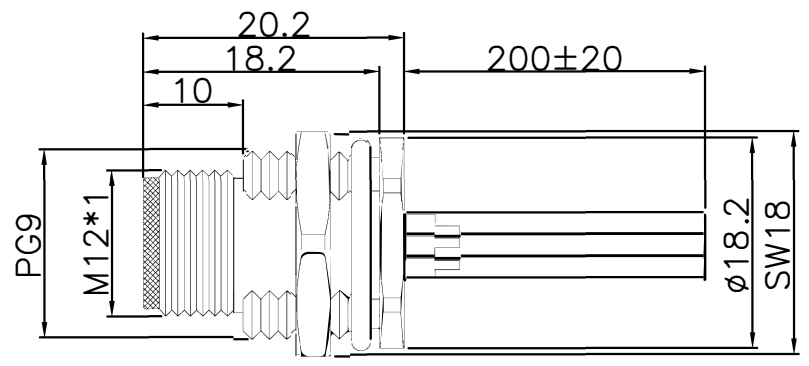

Specifications
 1. Durability: >500 mate/unmate cycles
 2. Operating Temperature: -40°C~+85°C
 3. Waterproofing Grade: IP67

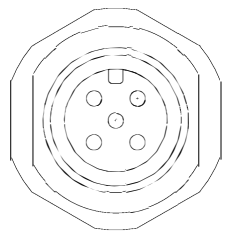
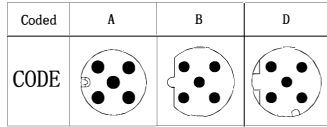

Material Specification

E	Wire	PVC 1007 26AWG				
E	O-RING	EPDM	BLACK	Pcs	1	
F	NUT	BRASS	NICKL PLATED	Pcs	1	
F	OUTER CONTACT	BRASS	NICKL PLATED	Pcs	1	
G	CONTACT	BRASS	GOLD PLATED	Pcs	3~8	
G	HOUSING	PA66+GF	BLACK	Pcs	1	
	No.	Specification	Material	Treat	Unit	Q'ty

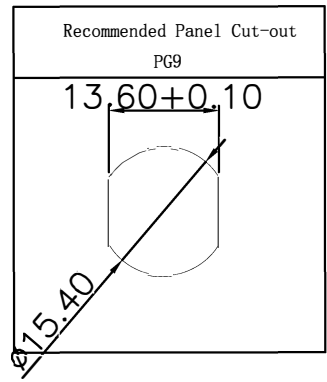

REV.	REVISION RECORD	DATE		GENERAL TOLERANCES		SCALE: 1:1	NAME	DATE	PART.NO:	DWG.NO:	
AO	NEW RELEASE	21.11.17		LINEAR	ANGLES	APPROVED			M12XXX-03-122	ENDE05	
			UNIT:mm	0.00±0.25	X°±3°	DESIGNER			TITLE:		
			SIZE: A4	0.000±0.10	X°X' ±2°	DRAWN			M12 waterproof cable end male front lock panel PG9F17T L=200mm	REV: AO	