

规格承认书

PECIFICATION FOR APPROVAL

客户

CUSTOMER: _____

客户物料

CUSTOMER NO. : _____

品名

ITEM: 压电式有源蜂鸣器 (内含驱动电路)

型号

TYPE: HND-2310B

规格

SPECIFICATION: φ23x H10mm 3500Hz 12VDC ≥85DB

客户承认

CUSTOMER CONFIRM AND SIGN

检查 TESTED BY	审核 CHECKED BY	承认 APPROVED BY

江苏华能电子有限公司

JIANGSU HUANENG ELECTRONIC CO.,LTD.

检查 TESTED BY	审核 CHECKED BY	承认 APPROVED BY
房露		

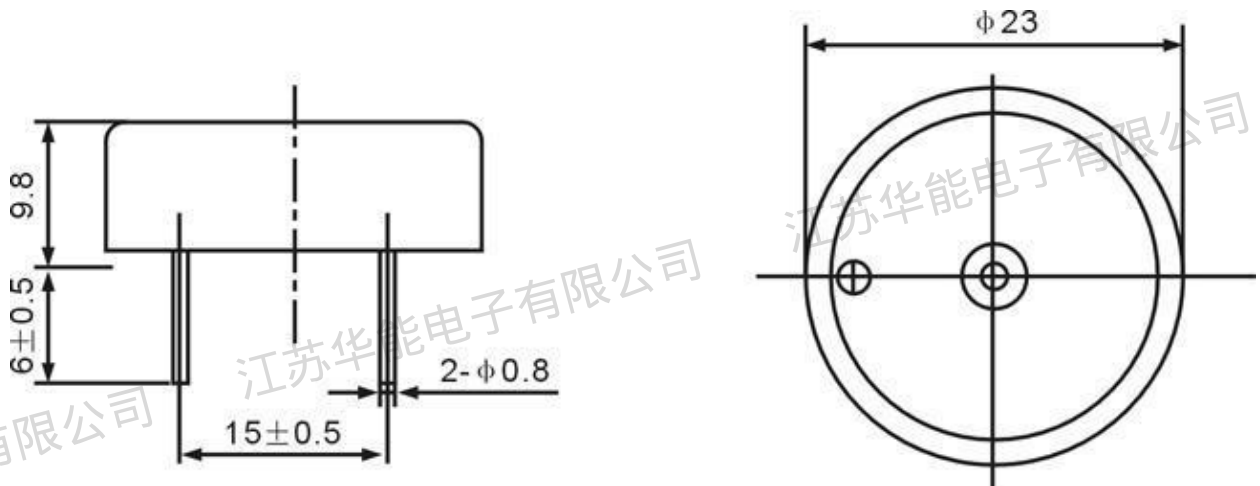
A: DIMENSION尺寸 (Unit单位 mm)

*Unit: mm; Tolerance: $\pm 0.3\text{mm}$ Except Specified*基本公差: $\pm 0.3\text{mm}$ 除特殊注明外

*Housing Material: Black ABS *外壳材料:Black ABS

*Terminal plate: 2 Tin needles, Alloy tin plated tin needle*线路板:2个合金镀锡针

B: SPECIFICATIONS规格参数

Model NO 型号		HND-2310B
Rated Voltage 额定电压	VDC	12
Operating Voltage 工作电压	VDC	3 ~ 24
*Max.Rated Current 最大额定电流	mA	Max.10
*Sound Pressure level(dB)/at10cm 输出音压 (测试距离 10 厘米)	dB	Min 85dB at Rated Voltage
*Resonant Frequency 谐振频率	Hz	3500 \pm 500
Operating Temperature 工作温度	$^{\circ}\text{C}$	-20 ~ +60
Storage Temperature 储存温度	$^{\circ}\text{C}$	-30 ~ +70
Case material and color 外壳材质和颜色		RoHS ABS/ Black
Weight 净重	g	

Measuring condition测试条件

Part shall be measured under a condition (Temperature: 5~35 $^{\circ}\text{C}$, Humidity: 45%~85%R.H., Atmospheric pressure: 860 ~ 1060hPa) unless the standard condition (Temperature: 25 \pm 3 $^{\circ}\text{C}$, Humidity: 60 \pm 10%R.H. Atmospheric pressure: 860 ~ 1060hPa) is regulated to measure.

产品测试条件: 温度: 5~35 $^{\circ}\text{C}$, 湿度: 45%~85%R.H., 气压: 860 ~ 1060hPa.

标准测试条件: 温度: 25 \pm 3 $^{\circ}\text{C}$, 湿度: 60 \pm 10%R.H. 气压: 860 ~ 1060hPa

C: Acoustic Characteristics 声学特征

The oscillation frequency, current consumption and sound pressure are measured by the measuring instruments shown below 振荡频率、电流消耗和声压测量仪器如下图所示

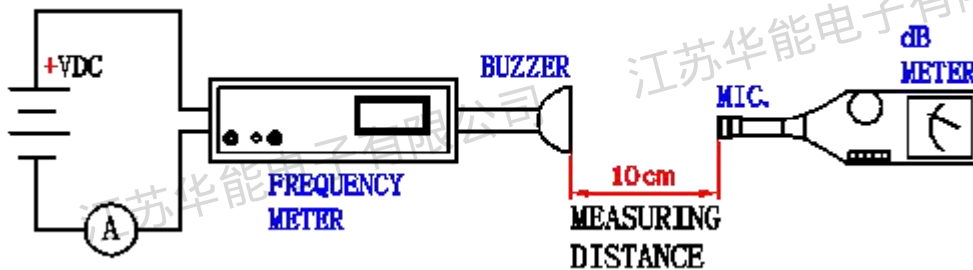

In the measuring test, buzzer is placed as follows 测量测试中蜂鸣器放置如下:

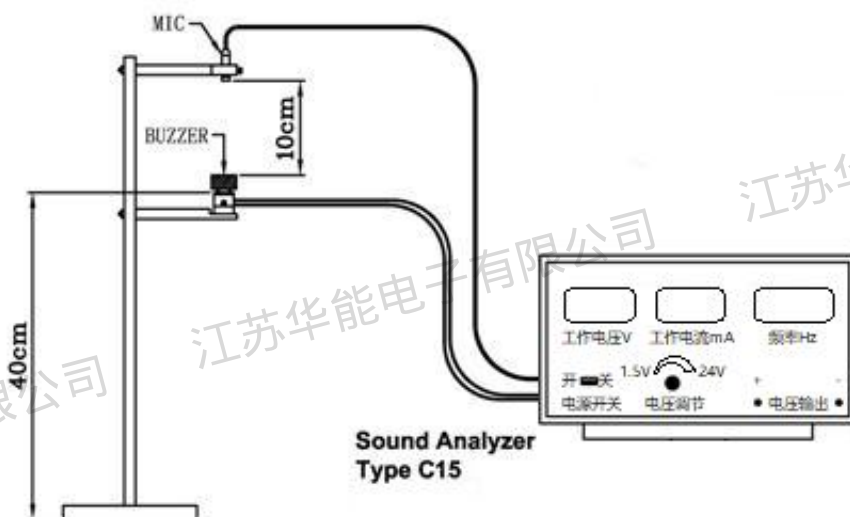

D: Typical Frequency Response Curve 频率响应曲线

dB-V

mA-V

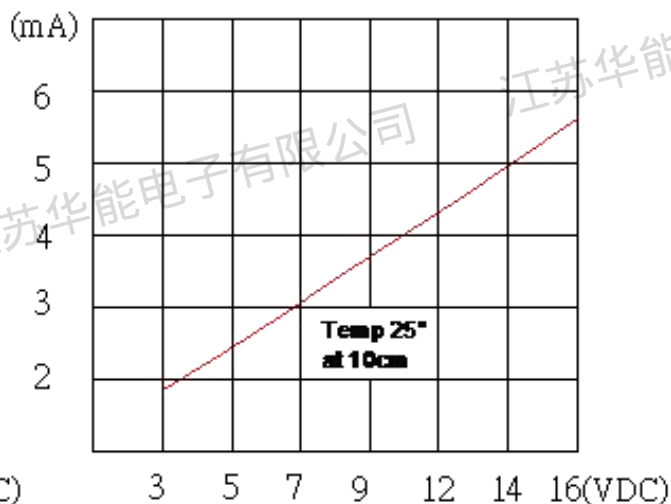
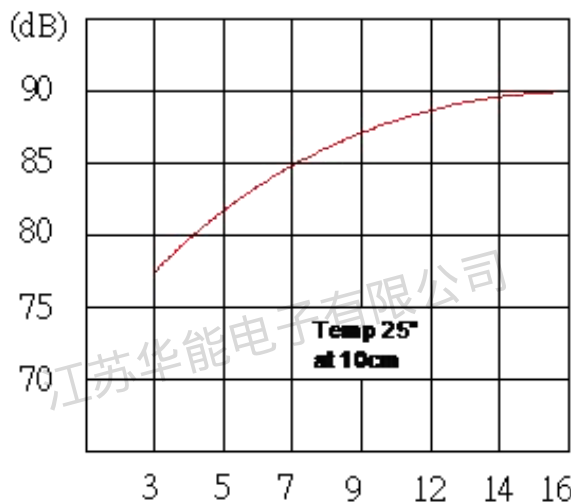

F: Reliability Test可靠性实验

After any following tests the part shall meet specifications without any degradation in appearance and performance except SPL. SPL shall not deviate more than -10 dB from the initial value. 在下面任何一项测试后都要符合以下标准，外观和电性能(除声压外)上不能有不良或衰减现象出现，声压不能低于规格说明书的最低声压的10dB。

1. Ordinary Temperature Life Test 寿命测试

The part shall be subjected to 96 hours at $25 \pm 10^\circ\text{C}$. Input rated voltage Resonant frequency, 1/2 duty Square wave. 将测试件置于 $25 \pm 10^\circ\text{C}$ 的温度下，输入额定电压、占空比为1/2的谐振频率方波测试96小时。

2. High Temperature Test 高温测试

The part shall be capable of with standing a storage temperature of $+80^\circ\text{C}$ for 96 hours. 将测试件置于 $+80^\circ\text{C}$ 的温度下存放96小时，取出置于常温下3小时而后测试。

3. Low Temperature Test 低温测试

The part shall be capable of with standing a storage temperature of -30°C for 96 hours. 将测试件置于 -30°C 的温度下存放96小时，取出置于常温下3小时而后测试。

4. Humidity Test 湿度测试

Temperature: $+40^\circ\text{C} \pm 3^\circ\text{C}$ Relative Humidity: 90%~95% Duration: 48 hours and expose to room temperature for 6 hours

将测试件置于温度 $+40 \pm 3^\circ\text{C}$ ，湿度90%~95%的条件下持续48小时，再置于室温下6小时而后测试。

5. Temperature Shock Test 温度冲击测试

Temperature: 75°C /1hour \rightarrow 25°C /3hours \rightarrow -30°C /1hour \rightarrow 25°C /3hours (1cycle) Total cycle: 10 cycles 将测试件置于以下温变条件下： 70°C 2小时 \rightarrow -25°C 2小时(1周期)，做完一个周期实验，过1个小时后再继续下一次实验，总测试周期数：10个周期。

6. Drop Test 跌落测试

Standard Packaging From 120mm(Drop on hard wood or board of 5cm thick, three sides, six plain.) 将测试件标准包装后(包装盒的3个边6个面)从1.2米的高度下跌落到厚木板或5厘米厚的硬木板上。

7. Vibration Test 振动测试

Vibration: 1000cycles /min. Amplitude: 1.5mm, Duration: 1 hour in each 3 axes

按以下条件实验后再测试：振速：1000次/分；振幅：1.5毫米；时间：1小时更换一个自由度方向共3个自由度方向。

Notice:

As this product is not protected from foreign material entering, please make sure that any foreign materials (e.g. magnetic powder, washing solvent, flux, corrosive gas) do not enter this product in your production processes. The functional degradation (e.g. SPL down) may occur if foreign material enter it.

需避免无关材料进入产品内，无关材料如：磁性材料、水溶性材料、腐蚀性的气体等。这些无关材料会影响产品的电性能。



G:PACKING FORMAT (UNIT:cm)包装



100只/盒

