

1. QUARTZ CRYSTAL OSCILLATOR SPECIFICATION

1.1 Frequency :	f _o	27.000MHz
1.2 Holder Type :		SMD7050
		±100ppm Overall
1.3 Frequency Stability :	f _{STAB}	Temperature stability is Inclusive of all conditions: Calibration Tolerance at +25°C, frequency stability over the operating temperature range, supply voltage change, output load changes, shock, vibration, and 1st year aging at +25°C.
1.4 Supply Voltage :	V _{DD}	3.3V _{DC} ±10%
1.5 Input Current :	I _{DD}	20mA max.
1.6 Operating temperature range :	T _{OPR}	-40°C To +85°C
1.7 Storage temperature range :	T _{STG}	-55°C To +125°C
1.8 Symmetry :	SYM	45~55% (at 50% V _{DD})
1.9 Rise& Fall Time :	Tr / Tf	5nS max.
1.10 Output Load :	RL	HCMOS 15pF
1.11 Output Low Level :	V _{OL}	10%V _{DD} max.
1.12 Output High level :	V _{OH}	90%V _{DD} min.
1.13 Output Wave form :		Square
1.14 Pin 1 Connection :		E/D Control
1.15 Start-up Time :	t _{str}	10mS max.
1.16 Standby Current :	T _{STD}	10uA max.
1.17 RMS Phase Jitter :	φ _J	1.0pS max. (Integrated from 12KHz to 20MHz)
1.18 Aging :		Less than ±3 ppm/Year
1.19 Insulation Resistance :		500MΩ (DC100±10V)min
1.20 Output Waveform :		Refer to fig.1
1.21 Test Circuit :		Refer to fig.2

Standard atmospheric conditions

Unless otherwise specified, the standard range of atmospheric conditions for making measurement and tests are as follow:

Ambient temperature : 25±3°C

Relative humidity : 40%~70%

2. Output Waveform

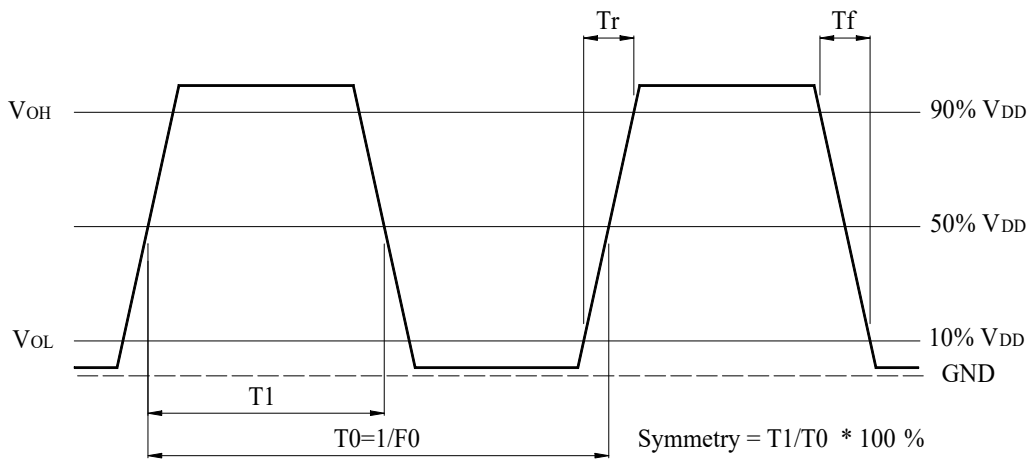

fig.1

3. Test circuit

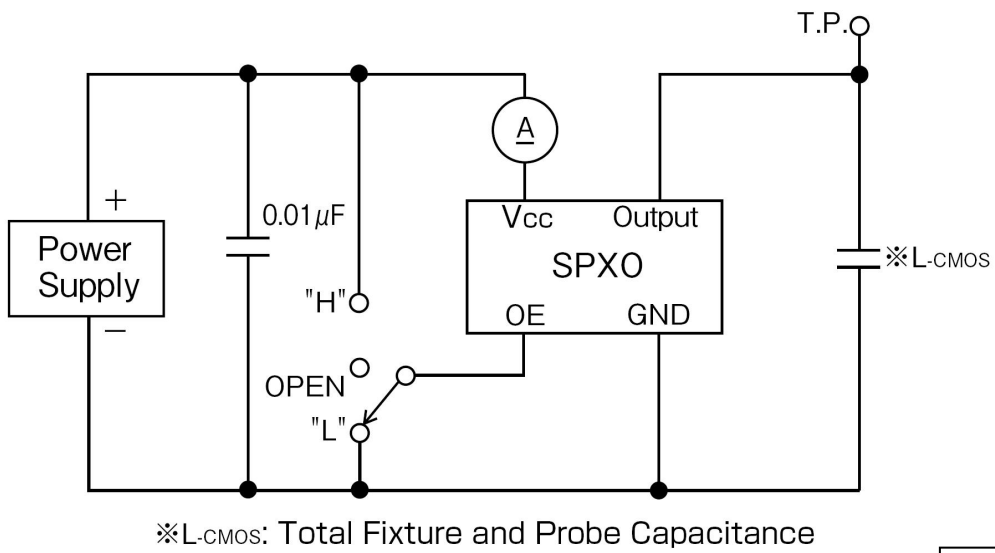
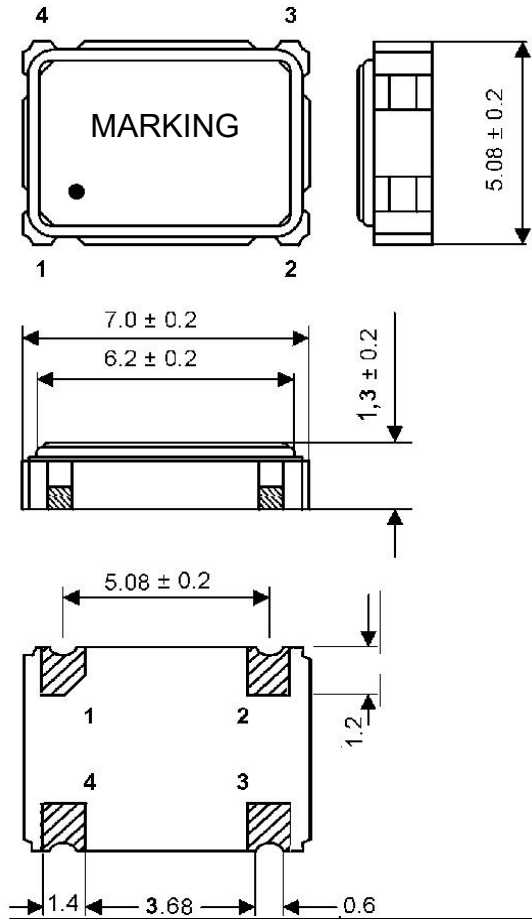

fig.2

4. MARKING & DIMENSIONS

(UNIT: mm)



Suggested soldering pad:

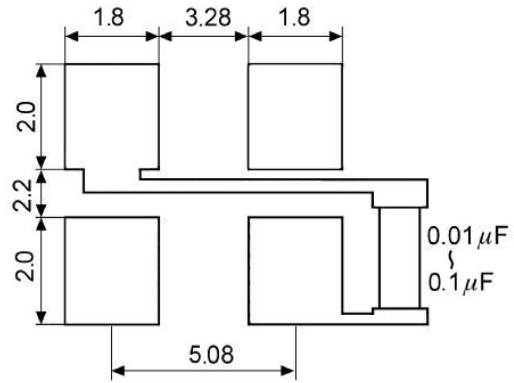

Pin	Connection
1	E/D
2	GND
3	Output
4	+V _{DD}

Reference drawing

Base:
Alumina Ceramic (Al_2O_3)
Metallized Pad: W
Ni Plating Au Plating
Cap:
Fe-Ni
(3) Crystal Enclosure Seal:
Seal Seam
(4) Crystal Blank
Rectangular At-Cut Quartz Crystal Blank
(5) Adhesive
Silver Conductive Polyimide Resin
(6) Electrode
Ag
(7) PAD
Alumina Ceramic (W. Ni. Au)

E/D: Enable/Disable Function

Pin 1# (E/D control)	Pin 3# (output)
Open (NC)	Active
High "1" ($V_{IH} \geq 70\%V_{DD}$)	Active
Low "0" ($V_{IL} \leq 30\%V_{DD}$)	High impedance
Disabled conditions:	
<ul style="list-style-type: none"> internal oscillator active output disabled, high impedance 	
Enable condition:	
<ul style="list-style-type: none"> pull the E/D pin to "H" if the oscillator should always be enabled 	

5. EMBOSS CARRIER TAPE & REEL

a.) Dimensions of Carrier Tape

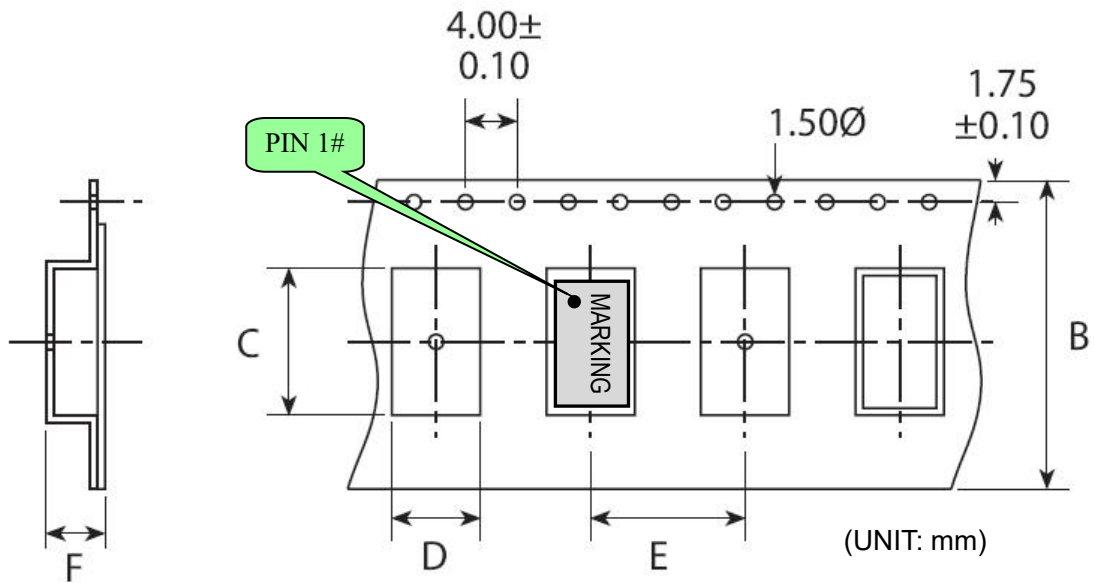

	A	B	C	D	E	F	G
OSC-SMD7050	178±2.0	16.0±0.3	7.40±0.10	5.40±0.10	8.0±0.1	2.2±0.2	60.5±1.0

b.) Dimensions of Reel

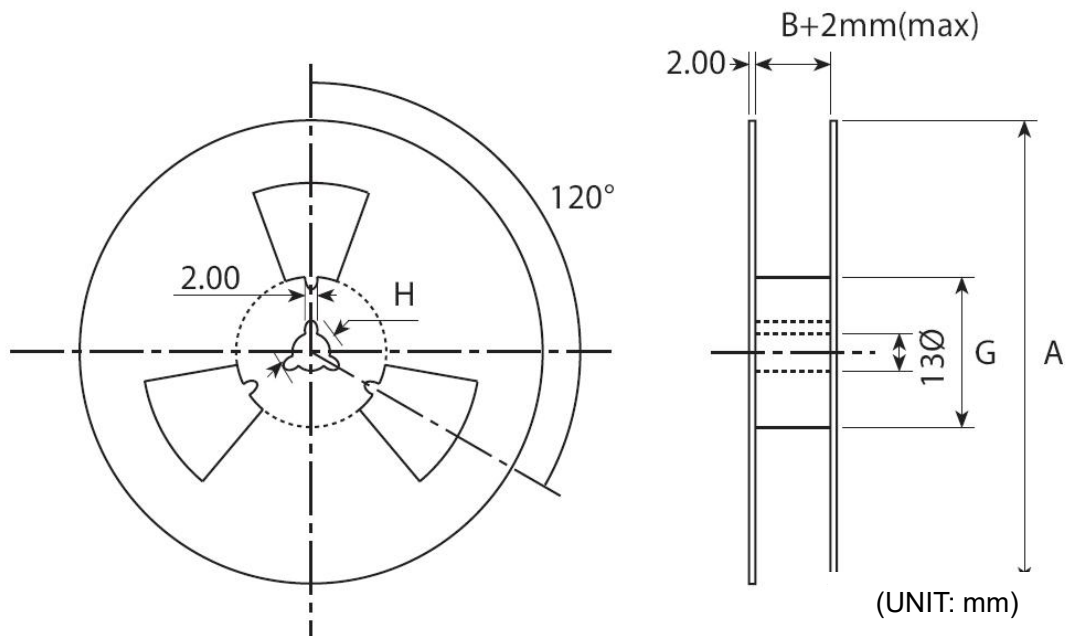

c.) Storage condition

Temperature: +40deg.C Max.

Relative Humidity: 80% Max.

d.) Standard packing quantity

1,000PCS / REEL

e.) Material of the tape

Material(Carrier tape) : Black conductive PS

Material (Cover tape) : Clear PE

Material (Reel) : PS

f.) Label contents

.The type of product

.Our specification No.

.Your Part No.

.Lot No.

.Nominal Frequency

.Quantity

.Our Company Name

Sticks label for every reel.

INSPECTION RECORDS

PO NO.:

CUSTOMER P/N:

FT P/N:

LOT NO.:

PACKAGE:

FREQUENCY:

REMARKS:

QUANTITY:

Chip Sun Technology Co.,Ltd.

g.) Taping dimension

Leader	Cover-tape	The length of cover-tape in the leader is more than 400 mm including empty embossed area.
	Carrier-tape	After all products were packaged, must remain more than twenty pieces or 400 mm empty area, which should be sealed by cover-tape.
Terminal	Cover-tape	The tip of cover-tape shall be fixed temporary by paper tape and roll around the core of reel one round.
	Carrier-tape	The empty embossed area which are sealed by top cover-tape must remain more the 40 mm.

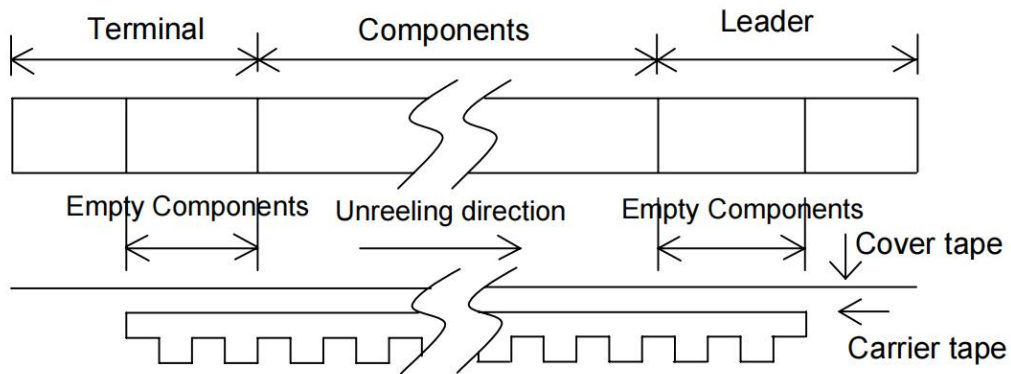

h.) Joint of tape

The carrier-tape and top cover-tape should not be jointed.

i.) Release strength of cover tape

It has to between 0.1N to 0.7N under following condition.

Pulling direction 165° to 180°

Speed 300mm/min.

Otherwise unless specified.

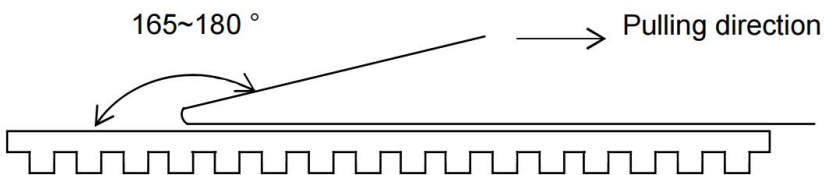

Other standards shall be based on JIS C 0806-1990.

6. Mechanical Endurance: Provided that measurement shall be carried out after letting it alone in the room temperature for 1 hour.

	Item	Conditions	Specifications
6.1	Drop	Fall freely from 100 cm of height 3 times on a firm wood	MIL-STD-202F-203B
6.2	Mechanical Shock	Device are shocked to half sine wave (1000 G) three mutually perpendicular axes each 3 times.	MIL-STD-202F
6.3	Vibration	(1)Vibration Frequency: 10~55Hz (2)Cycle: 1 to 2 Min. (3)Full Cycle: 1.5mm P-P. (4)Direction: X.Y.Z (5)Time: 2 Hours / Each Direction	MIL-STD-883E
6.4	Substrate Bending	Mount the specimen on substrate. Apply the following pressure Direction: see Fig -1 Speed: 0.5 mm/sec Hours: 5 ± 1 sec Amount of substrate: 3 mm Max.	Without mechanical damage such as breaks. Without electrode peeling. Electrical characteristics shall be satisfied.
6.5	Adhesion	Mount the specimen on substrate. Apply the following pressure Direction: see Fig -2 Weight: 10N Hours: 10 ± 1 sec	
6.6	Body strength	Mount the specimen on substrate. Apply the following pressure Direction: see Fig -3 Weight: 10N Hours: 10 ± 1 sec	
6.7	Seal	Fine Leak: 4.5kgf/cm ² 2hours 1×10 ⁻⁹ Pa.m ³ /sec Gross Leak: 4.5kgf/cm ² 2hours 1.5×10 ⁻⁵ Pa.m ³ /sec	MIL-STD-883E

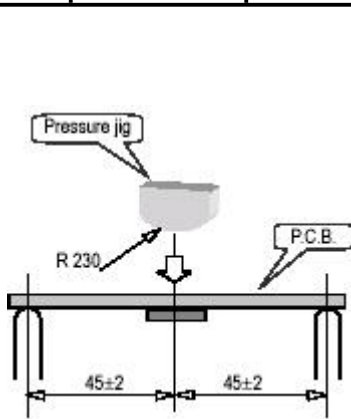

Fig-1

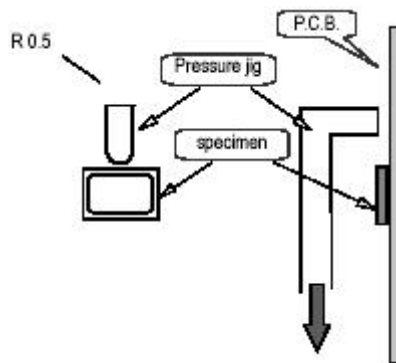

Fig-2

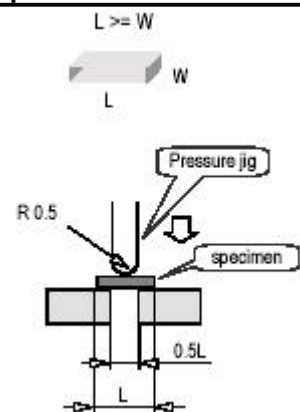
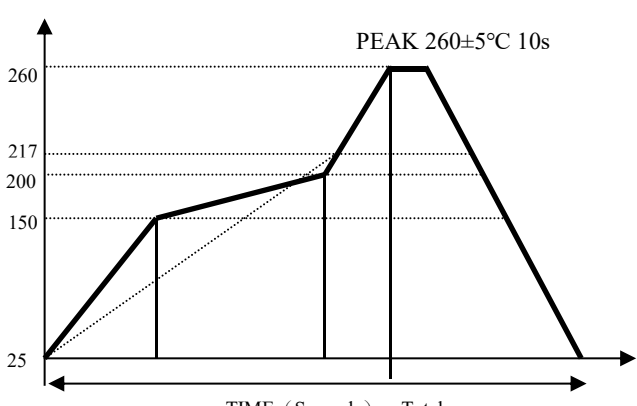

Fig-3

6.8	Solder ability	Pre-heat temperature : $+150\pm 10^{\circ}\text{C}$ Pre-heat time : 60~120s When the temperature of the specimen is reached at $+215\pm 3^{\circ}\text{C}$, it shall be left for $30\pm 1\text{sec}$. Peak temperature $240\pm 5^{\circ}\text{C}$ Material: Pb-free (Sn-3.0Ag-0.5Cu) Flux : Rosin resin methyl alcohol solvent (1:4) The electrodes should be covered by a new solder at least 90% of immersed area.	MIL-STD-883E 2003
-----	----------------	--	-------------------

6.9	Resistance to Soldering Heat	<p>Run in Reflow Reflow soldering shall be allowed Only two(2) time.</p> <p style="text-align: center;">Available for Lead Free Soldering</p>  <p style="text-align: center;">TIME (Seconds) Total :</p> <table border="1" data-bbox="446 1299 1037 1456"> <tr> <td>(1)</td> <td>Preheat</td> <td>160~180 deg.C</td> <td>120sec.</td> </tr> <tr> <td>(2)</td> <td>Primary heat</td> <td>220 deg.C</td> <td>60sec.</td> </tr> <tr> <td>(3)</td> <td>Peak</td> <td>260 deg.C</td> <td>10sec. Max.</td> </tr> </table>	(1)	Preheat	160~180 deg.C	120sec.	(2)	Primary heat	220 deg.C	60sec.	(3)	Peak	260 deg.C	10sec. Max.	MIL-STD-202F
(1)	Preheat	160~180 deg.C	120sec.												
(2)	Primary heat	220 deg.C	60sec.												
(3)	Peak	260 deg.C	10sec. Max.												

7. Environmental Endurance: Provided that measurement shall be carried out after letting it alone in the room temperature for 1 hour.

	Item	Conditions	Specifications
7.1	Humidity	+85°C±2°C, RH 80~85%, Duration of 500 hours. The units are then allowed to stand for approx 2 hours in room temperature before checking	MIL-STD-202F
7.2	Storage in Low Temperature	Temperature: -40±2°C , Duration of 500 hours. The units are then allowed to stand at room temperature for approx 2 hours before checking.	MIL-STD-883E
7.3	Storage in High Temperature	Temperature: +85°C±2°C , Duration of 500 hours. The units are then allowed to stand at room temperature for approx 2 hours before checking.	MIL-STD-883E
7.4	Thermal Shock	Temperature 1: -55°C±5°C Temperature 2: 125°C±5°C Temperature change between T1 and T2 at soonest Run 100 cycles, maintain T1 and T2 30minutes each in one cycle (Refer to Fig-4)	MIL-STD-883E

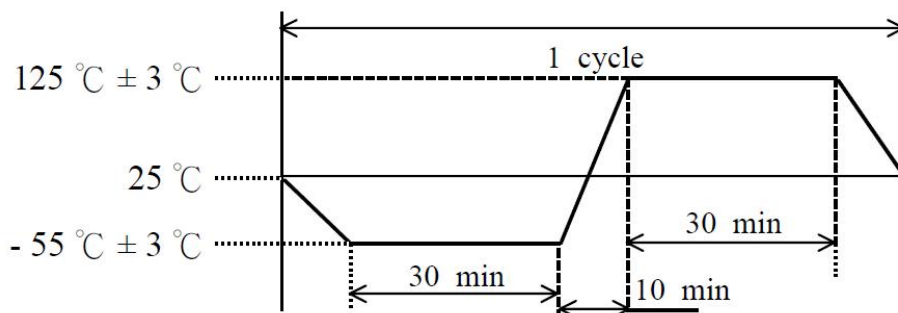

8. STRUCTURE ILLUSTRATION

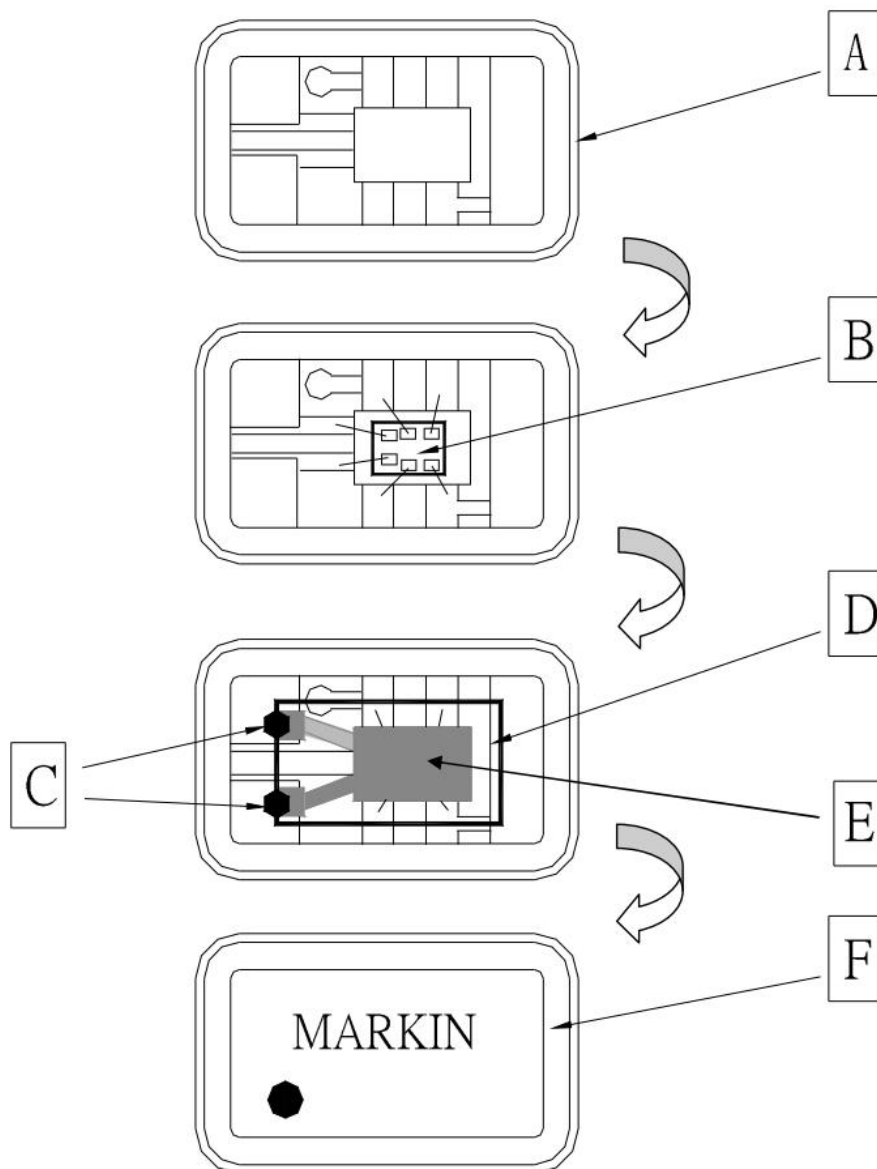

COMPONENTS		METERIALS	COMPONENTS		METERIALS
A	Base (Package)	Ceramic(Al_2O_3) + Kovar(Fe+Co+Ni)	D	Crystal blank	SiO_2
B	IC Chip	Si	E	Electrode	Cr+Ag
C	Conductive adhesive	Ag+Silicon resin	F	Lid	Kovar(Fe+Co+Ni)

9. The production technical :

Reflow Condition:

