

HF-LPD1X0

802.11a/b/g/n WiFi Module User Manual

V 1.3



HF-LPD100



HF-LPD130

Overview of Characteristic

- ◇ Support IEEE802.11 a/b/g/n Wireless Standards, work in 2.4GHz and 5GHz dual band
- ◇ Based on Andes Core, 160MHz CPU, 192KB RAM, 2MB 或 8MB Flash
- ◇ Support UART Data Communication Interface
- ◇ Support Work As STA/AP/AP+STA Mode
- ◇ Support Sniffer Method SmartLink V8 Config
- ◇ **Support SoftAP Method SmartAPLink Config**
- ◇ Support WeChat Airkiss 2.0
- ◇ Support Wireless and Remote Firmware Upgrade Function
- ◇ Support Software SDK for Develop
- ◇ Support Different Antenna Option
 - HF-LPD100: Internal PCB, External 3rd Generation IPEX or External Antenna Pad
 - HF-LPD130: External 1st Generation IPEX

◇ **Single +3.3V Power Supply**

◇ **Size:**

■ **HF-LPD100: 23.1mm x 32.8mm x 3.5mm, SMT48 package**

■ **HF-LPD130: 22mm x 14.3mm x 8mm, DIP10 package**

◇ **FCC/CE/SRRC/RoHS Certificated (TBD)**

TABLE OF CONTENTS

LIST OF FIGURES	7
LIST OF TABLES	9
HISTORY	10
1. PRODUCT OVERVIEW	11
1.1. General Description	11
1.1.1 Key Application	11
1.1.2 Device Parameters	12
1.2. Hardware Introduction	13
1.2.1. HF-LPD100 Pins Definition.....	14
1.2.2. HF-LPD130 Pins Definition.....	16
1.2.3. Electrical Characteristics	18
1.2.4. HF-LPD100 Mechanical Size.....	19
1.2.5. HF-LPD130 Mechanical Size.....	20
1.2.6. HF-LPD100 On-board PCB Antenna.....	21
1.2.7. External Antenna	22
1.2.8. Evaluation Kit.....	22
1.2.9. Order Information.....	23
1.2.10. Hardware Typical Application.....	24
2. FUNCTIONAL DESCRIPTION	26
2.1. Wireless Networking	26
2.1.1. Basic Wireless Network Based On AP	26
2.1.2. Wireless Network Based On STA.....	26
2.2. Work Mode : Transparent Transmission Mode	27
2.3. Encryption	27
2.4. Parameters Configuration	27
2.5. Firmware Update	28
2.6. SOCKET B Function	28
2.7. Multi-TCP Link Connection	28
2.8. 2.4GHz and 5GHz Dual Band	29
3. OPERATION GUIDELINE	31
3.1. Configuration	31
3.1.1. Open Web Management Interface	31
3.1.2. System Page.....	32
3.1.3. Work Mode Page	32
3.1.4. STA Setting Page	33
3.1.5. AP Setting Page	34
3.1.6. Other Setting Page	34
3.1.7. Account Management Page	35
3.1.8. Upgrade Software Page	35

3.1.9.	Restart Page	35
3.1.10.	Restore Page	36
3.1.11.	Internal Webpage	36
3.2.	Usage Introduction	37
3.2.1.	Software Debug Tools	37
3.2.2.	Network Connection	37
3.2.3.	Default Parameter Setting	37
3.2.4.	Module Debug.....	38
3.3.	Typical Application Examples	39
3.3.1.	Wireless Control Application.....	39
3.3.2.	Remote Management Application.....	40
3.3.3.	Transparent Serial Port Application.....	40
4.	AT+INSTRUCTION INTRODUCTION	41
4.1.	Configuration Mode	41
4.1.1.	Switch to Configuration Mode.....	41
4.1.2.	Send AT Command in Transparent Transmission Mode	42
4.2.	AT+Instruction Set Overview	42
4.2.1.	Instruction Syntax Format.....	43
4.2.2.	AT+Instruction Set	44
4.2.2.1.	AT+E	45
4.2.2.2.	AT+CMDPW.....	46
4.2.2.3.	AT+WMODE	46
4.2.2.4.	AT+ENTM	46
4.2.2.5.	AT+TMODE.....	47
4.2.2.6.	AT+MID	47
4.2.2.7.	AT+VER	47
4.2.2.8.	AT+RELD	47
4.2.2.9.	AT+FCLR	48
4.2.2.10.	AT+Z.....	48
4.2.2.11.	AT+H	48
4.2.2.12.	AT+CFGTF	48
4.2.2.13.	AT+UART	48
4.2.2.14.	AT+PING	49
4.2.2.15.	AT+NETP	49
4.2.2.16.	AT+MAXSK	50
4.2.2.17.	AT+TCPLK	50
4.2.2.18.	AT+TCPTO.....	50
4.2.2.19.	AT+TCPDIS.....	51
4.2.2.20.	AT+SEND	51
4.2.2.21.	AT+RECV	51
4.2.2.22.	AT+SOCKB	52
4.2.2.23.	AT+TCPDISB	52
4.2.2.24.	AT+TCPTOB	52
4.2.2.25.	AT+TCPLKB	53

4.2.2.26.	AT+SNDB	53
4.2.2.27.	AT+RCVB	53
4.2.2.28.	AT+UDPLCPT	54
4.2.2.29.	AT+WSSSID	54
4.2.2.30.	AT+WSKEY	54
4.2.2.31.	AT+WANN	55
4.2.2.32.	AT+WSMAC	55
4.2.2.33.	AT+WSLK	55
4.2.2.34.	AT+WSLQ	56
4.2.2.35.	AT+WSCAN	56
4.2.2.36.	AT+LANN	56
4.2.2.37.	AT+WAP	57
4.2.2.38.	AT+WAKEY	57
4.2.2.39.	AT+WADHCP	57
4.2.2.40.	AT+WALK	58
4.2.2.41.	AT+WALKIND	58
4.2.2.42.	AT+WAPMXSTA	58
4.2.2.43.	AT+MDCH	59
4.2.2.44.	AT+OTA	59
4.2.2.45.	AT+UPURL	59
4.2.2.46.	AT+DISPS	60
4.2.2.47.	AT+PLANG	60
4.2.2.48.	AT+WEBU	60
4.2.2.49.	AT+WRMID	61
4.2.2.50.	AT+ASWD	61
4.2.2.51.	AT+SMTLK	61
4.2.2.52.	AT+NDBGL	61
4.2.2.53.	AT+TYPE	62
4.2.2.54.	AT+SMEM	62
4.2.2.55.	AT+WIFI(Reserved)	62
4.2.2.56.	AT+WFREQ	63
4.2.2.57.	AT+SMARTAPCONFIG	63
4.2.2.58.	AT+SMARTAPSTART	63
5.	PACKAGE INFORMATION	65
5.1.	Recommended Reflow Profile	65
5.2.	Device Handling Instruction (Module IC SMT Preparation)	65
5.3.	HF-LPD100 Shipping Information	66
	APPENDIX A: HW REFERENCE DESIGN	67
	APPENDIX B: HTTP PROTOCOL TRANSFER	68
	B.1. Sending HTTP Raw Data in Throughput Mode	68
	APPENDIX C: REFERENCES	69
	C.1. High-Flying Mass Production Tool	69

C.2. SmartLink APP V8 Sniffer Config Tool	69
C.3. SmartAPLink.....	69
C.4. Firmware	69
C.5. SDK.....	69
APPENDIX D: CONTACT INFORMATION	70

LIST OF FIGURES

Figure 1.	HF-LPD100 Appearance	13
Figure 2.	HF-LPD100-2 Appearance	13
Figure 3.	HF-LPD130 Appearance	13
Figure 4.	HF-LPD100 Pins Map	14
Figure 5.	HF-LPD130 Pins Map	16
Figure 6.	HF-LPD130 Debug Pins Map	17
Figure 7.	HF-LPD100-1 and -0 Mechanical Dimension	19
Figure 8.	HF-LPD100-2 Mechanical Dimension	20
Figure 9.	HF-LPD100 Mechanical Dimension	21
Figure 10.	Suggested Module Placement Region	21
Figure 11.	HF-LPD100 EVK	22
Figure 12.	HF-LPD100 Order Information	23
Figure 13.	HF-LPD130 Order Information	24
Figure 14.	HF-LPD100 Hardware Typical Application	24
Figure 15.	HF-LPD100 Basic Wireless Network Structure	26
Figure 16.	HF-LPD100 STA Network Structure	26
Figure 17.	Socket B function demo	28
Figure 18.	Multi-TCP Link Data Transmission Structure	29
Figure 19.	AP Scan result	29
Figure 20.	2.4G Environment	30
Figure 21.	5G Environment	30
Figure 22.	Open Web Management page	31
Figure 23.	System Web Page	32
Figure 24.	Work Mode Page	32
Figure 25.	STA Setting Page	33
Figure 26.	STA Scan Page	33
Figure 27.	AP Setting Page	34
Figure 28.	Other Setting Page	34
Figure 29.	Account Page	35
Figure 30.	Upgrade SW page	35
Figure 31.	Restart Page	36
Figure 32.	Restore Page	36
Figure 33.	Internal Webpage	37
Figure 34.	STA Interface Debug Connection	37
Figure 35.	AP Interface Debug Connection	37
Figure 36.	“CommTools” Serial Debug Tools	38
Figure 37.	“TCPUDPDbg” Tools Create Connection	38
Figure 38.	“TCPUDPDbg” Tools Setting	39
Figure 39.	“TCPUDPDbg” Tools Connection	39
Figure 40.	Wireless Control Application	39
Figure 41.	Remote Management Application	40
Figure 42.	Transparent Serial Port Application	40

Figure 43.	HF-LPD100 Default UART Port Parameters	41
Figure 44.	Switch to Configuration Mode.....	41
Figure 45.	“AT+H” Instruction for Help	43
Figure 46.	Reflow Soldering Profile	65
Figure 47.	HF-LPD100/HF-LPT230 Shipping Information	66

LIST OF TABLES

Table1.	HF-LPD1X0 Module Technical Specifications	12
Table2.	HF-LPD100 Pins Definition	14
Table3.	HF-LPD130 Pins Definition	16
Table4.	Absolute Maximum Ratings:.....	18
Table5.	Power Supply & Power Consumption:	18
Table6.	HF-LPD100 External Antenna Parameters	22
Table7.	HF-LPD100 Evaluation Kit Interface Description	23
Table8.	HF-LPD100 Web Access Default Setting.....	31
Table9.	Error Code Description	44
Table10.	AT+Instruction Set List	44
Table11.	Reflow Soldering Parameter	65

HISTORY

- Ed. V0.1** 08-24-2017 Internal Version.
- Ed. V1.0** 10-26-2018 Released Version
- Ed. V1.1** 06-04-2019 Add HF-LPD130 Version
- Ed. V1.2** 09-29-2019 Add HF-LPD100 external pin antenna
- Ed. V1.3** 11-13-2019 Update PIN definition.

1. PRODUCT OVERVIEW

1.1. General Description

The HF-LPD1X0 support 2.4GHz and 5GHz dual band. It is a fully self-contained small form-factor, single stream, 802.11b/g/n Wi-Fi module, which provide a wireless interface to any equipment with a Serial interface for data transfer.HF-LPD1X0 integrate MAC, baseband processor, RF transceiver with power amplifier in hardware and all Wi-Fi protocol and configuration functionality and networking stack, in embedded firmware to make a fully self-contained 802.11b/g/n Wi-Fi solution for a variety of applications.

The HF-LPD1X0 employs the world's lowest power consumption embedded architecture. It has been optimized for all kinds of client applications in the home automation, smart grid, handheld device, personal medical application and industrial control that have lower data rates, and transmit or receive data on an infrequent basis.

1.1.1 Key Application

- Remote equipment monitoring
- Asset tracking and telemetry
- Security
- Industrial sensors and controls
- Home automation
- Medical devices

1.1.2 Device Parameters

Table1. HF-LPD1X0 Module Technical Specifications

Class	Item	Parameters
Wireless Parameters	Certification	TBD
	Wireless standard	2.4GHz: 802.11 b/g/n 5GHz: 802.11 a
	Frequency range	2.412GHz-2.484GHz(CH1,13) 5.17GHz-5.25GHz(CH36,40,44,48) U-NII-1 5.25GHz-5.35GHz(CH52,56,60,64) U-NII-2 5.725GHz-5.835GHz(CH149,153,157,161,165) U-NII-3
	2.4G Transmit Power	802.11b: +18dBm (@11Mbps)
		802.11g: +16dBm (@54Mbps)
		802.11n: +15dBm (@HT20, MCS7)
	5G Transmit Power	13.5dBm (OFDM 54Mbps)
		13.5dBm (HT20 MCS7)
		13dBm (HT40 MCS7)
	2.4G Receiver Sensitivity	802.11b: -87.5 dBm (@11Mbps ,CCK)
802.11g: -73.5 dBm (@54Mbps, OFDM)		
802.11n: -72.5 dBm (@HT20, MCS7)		
5G Receiver Sensitivity	-73.5dBm (@54Mbps ,OFDM)	
	-72 dBm (HT20,MCS7)	
Antenna Option	HF-LPD100: Internal: PCB antenna External: 3 rd Generation IPEX antenna or antenna PAD. HF-LPD130: External: 1 st Generation IPEX antenna	
Hardware Parameters	Data Interface	UART
		GPIO,SPI
	Operating Voltage	2.1~3.46V
	Operating Current	Peak (Continuous TX): 345mA Average(STA, No data): 44mA Standby: 1.23mA(Reset set to low)
	Operating Temp.	-20°C- 85°C
	Storage Temp.	-40°C- 125°C
	Density	<85%
Dimensions and Size	HF-LPD100: 23.1mm x 32.8mm x 3.5mm HF-LPD130: 22mm x 14.3mm x 8mm	
Software Parameters	Network Type	STA/AP/AP+STA
	Security Mechanisms	WEP/WPA-PSK/WPA2-PSK
	Encryption	WEP64/WEP128/TKIP/AES
	Update Firmware	Local Wireless, Remote OTA
	Customization	Support SDK for application develop
	Network Protocol	IPv4, TCP/UDP/HTTP/TLS(SDK)
	User Configuration	AT+instruction set. Android/ iOS SmartLink APP tools

1.2. Hardware Introduction

HF-LPD1X0 series Wi-Fi module appearance is as following.

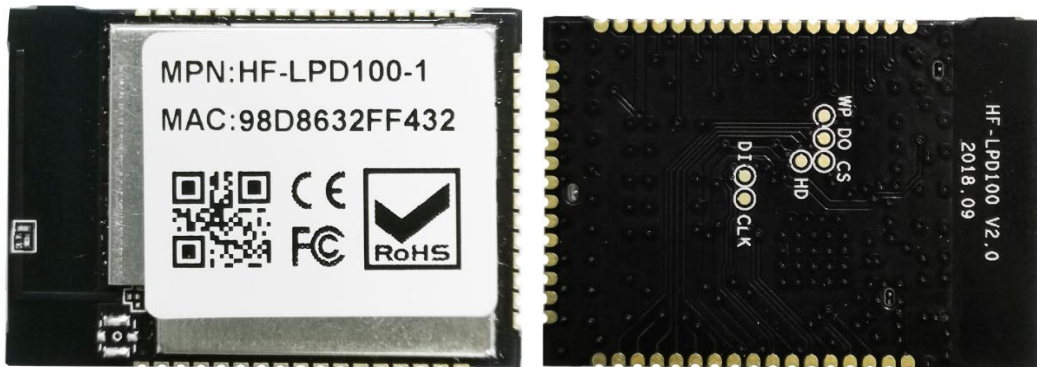

Figure 1. HF-LPD100 Appearance



Figure 2. HF-LPD100-2 Appearance



Figure 3. HF-LPD130 Appearance

1.2.1. HF-LPD100 Pins Definition

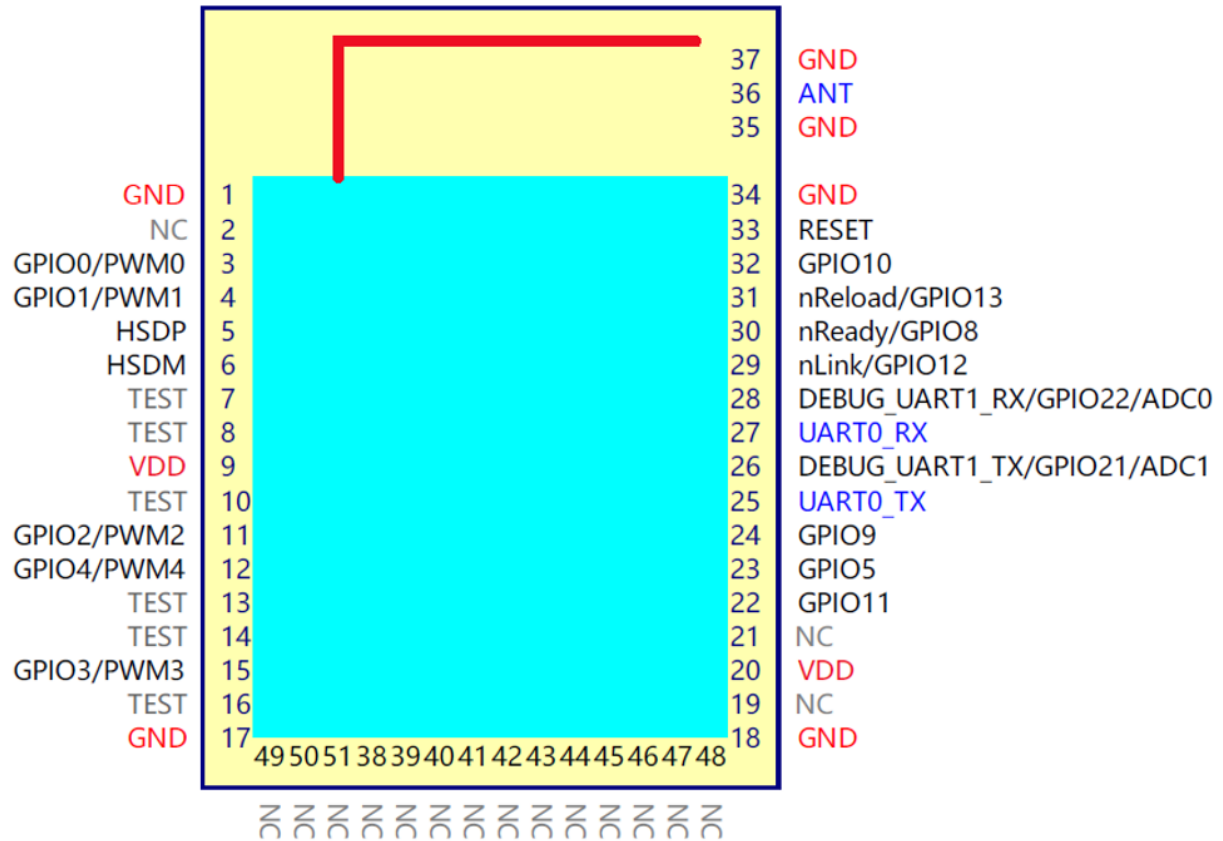

Figure 4. HF-LPD100 Pins Map

Table2. HF-LPD100 Pins Definition

Pin	Description	Net Name	Signal Type	Comments
1,17,18 34,35,37	Ground	GND	Power	
2		NC		
3	GPIO00	GPIO00	I/O	PWM0
4	GPIO01	GPIO01	I/O	PWM1
5	USB+	HSDP	I/O	USB 2.0
6	USB-	HSDN	I/O	USB 2.0
7		TEST		
8		TEST		
9,20	+3.3V 电源	DVDD	Power	
10		TEST		
11	GPIO02	GPIO02	I/O	PWM2
12	GPIO04	GPIO04	I/O	PWM4
13		TEST		
14		TEST		
15	GPIO03	GPIO03	I/O	PWM3

Pin	Description	Net Name	Signal Type	Comments
16		TEST		
19		NC		
21		NC		
22	GPIO11	GPIO11	I/O	
23	GPIO05	GPIO05	I/O	
24	GPIO09	GPIO09	I/O	
25	UART0_TX	UART0_TX	O	3.3V TTL UART0 Output GPIO07
26	UART1_TX	DEBUG_UART1_TX	I/O	3.3V TTL Debug UART1_TX GPIO21, ADC1
27	UART0_RX	UART0_RX	I	3.3V TTL UART0 Input GPIO06
28	UART1_RX	DEBUG_UART1_RX	I/O	3.3V TTL Debug UART1_RX GPIO22, ADC0
29	Wi-Fi Status	nLink	IPD/O	“0” – Wi-Fi connect to router “1” – Wi-Fi unconnected; Detailed functions see <Notes> GPIO12
30	Module Boot Up Indicator	nReady	IPU/O	“0” – Boot-up OK; “1” – Boot-up No OK; GPIO08
31	Multi-Function	nReload	IPU/O	Detailed functions see <Notes> GPIO13
32		N.C		
33	Module Reset	RESET	I,PU	“Low” effective reset input. There is RC reset circuit internally.
35,37	Ground	GND	Power	Only HF-LPD100-2 has this three pin for antenna interface
36		ANT		

1.2.2. HF-LPD130 Pins Definition

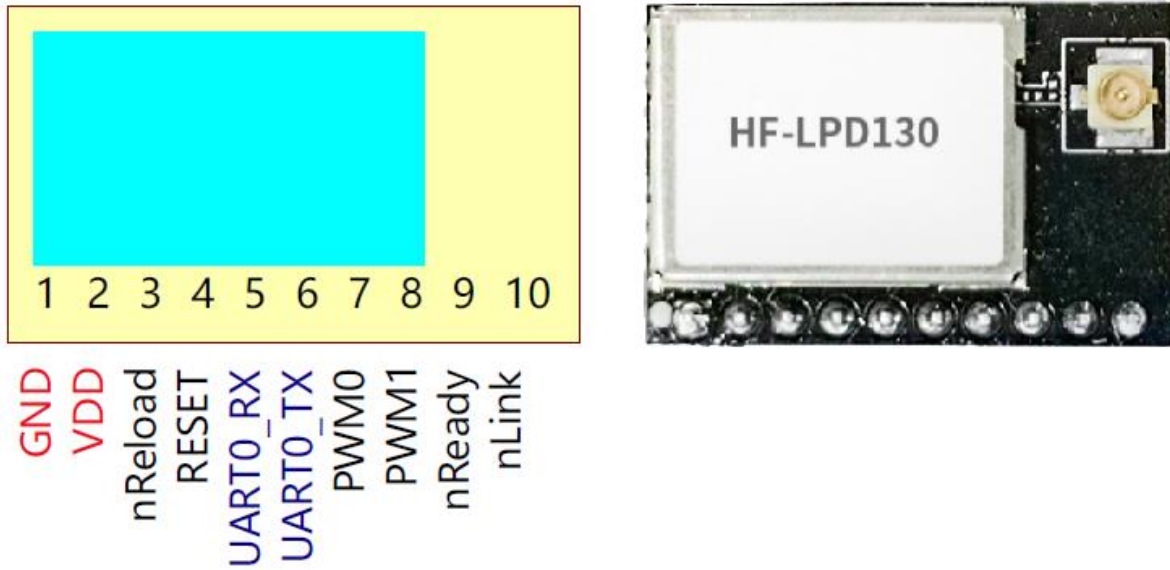

Figure 5. HF-LPD130 Pins Map

Table3. HF-LPD130 Pins Definition

Pin	Description	Net Name	Signal Type	Comments
1	Ground	GND	Power	
2	+3.3V Power	DVDD	Power	
3	Multi-Function	nReload	I,PU	Detailed functions see <Notes> GPIO4, PWM4
4	Module Reset	RESET	I,PU	“Low” effective reset input. There is RC reset circuit internally.
5	UART0	UART0_RX	I	3.3V TTL UART0 Communication Input
6	UART0	UART0_TX	O,PU	3.3V TTL UART0 Communication Output
7	PWM0	PWM0	IPU/O	GPIO0
8	PWM1	PWM1	IPU/O	GPIO1
9	Module Boot Up Indicator	nReady	O	“0” – Boot-up OK; “1” – Boot-up No OK; GPIO2, PWM2
10	Wi-Fi Status	nLink	O	“0” – Wi-Fi connect to router “1” – Wi-Fi unconnected; Detailed functions see <Notes> GPIO3,PWM3

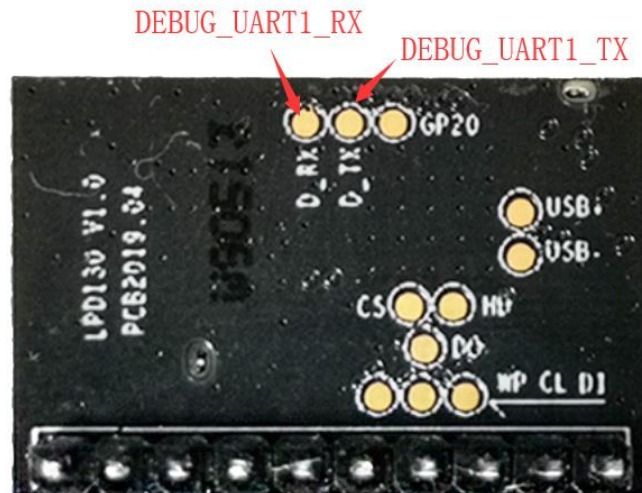

Figure 6. HF-LPD130 Debug Pins Map

Pin	Description	Net Name	Signal Type	Comments
	UART1	DEBUG_UART1_RX	I	3.3V TTL Debug UART1 Input
	UART1	DEBUG_UART1_TX	O	3.3V TTL Debug UART1 Output

<Notes>

I — Input; O — Output

PU—Internal Resistor Pull Up; I/O: Digital I/O; Power—Power Supply

nReload Pin (Button) function:

1. When this pin is set to “low” during module boot up, the module will enter wireless firmware and config upgrade mode. This mode is used for customer manufacture. (See Appendix to download software tools for customer batch configuration and upgrade firmware during mass production)
2. After module is powered up, short press this button (0.2s < “Low” < 1.5s) and loose to make the module go into SmartLink V8 config mode, when in SmartLink V8 config mode and short press this button again to go into SmartAPLink config mode, waiting for APP to set router SSID and password, config module connect to router.

Recommend to use SmartAPLink method config.

See Appendix to download SmartLink V8 and SmartAPLink APP

3. After module is powered up, long press this button (“Low” > 4s) and loose to make the module recover to factory setting.

High-Flying strongly suggest customer fan out this pin to connector or button for “Manufacture” upgrade or “ SmartLink” application.

nReady Pin (LED) function(Low effective):

1. OS initial finished indicator. Only after this pin output low, can the UART function be used.

nLink Pin (LED) function(Low effective):

1. At wireless firmware and config upgrade mode , this LED used to indicate configure and upgrade status.
2. At “SmartLink” config mode, this LED is used to indicate APP to finish setting.
3. At normal mode, it’s Wi-Fi link status indicator. Output Low when STA mode connect to router AP or other STA connect to it when in AP mode.

High-Flying strongly suggest customer fan out this pin to LED.

UART1 Debug :

1. Is used for debug log

1.2.3. Electrical Characteristics

Table4. Absolute Maximum Ratings:

Parameter	Condition	Min.	Typ.	Max.	Unit
Work temperature range		-20		85	°C
Maximum soldering temperature	IPC/JEDEC J-STD-020			260	°C
ESD (Human Body Model HBM)	TAMB=25°C			2.5	KV
ESD (MM)	TAMB=25°C			0.25	KV

Table5. Power Supply & Power Consumption:

Parameter	Condition	Min.	Typ.	Max.	Unit
Operating Supply voltage		2.1	3.3	3.46	V
Supply current, peak	Continuous Tx		260		mA
Supply current,	STA No data transfer		27		mA
Supply current,	STA Continuous data transfer		35		mA
Supply current,	AP		80		mA
GPIO sink current	GND+0.5V		20		mA
GPIO pull current	VCC-0.5V		20		mA

1.2.4. HF-LPD100 Mechanical Size

HF-LPD100 modules physical size (Unit: mm) as follows:

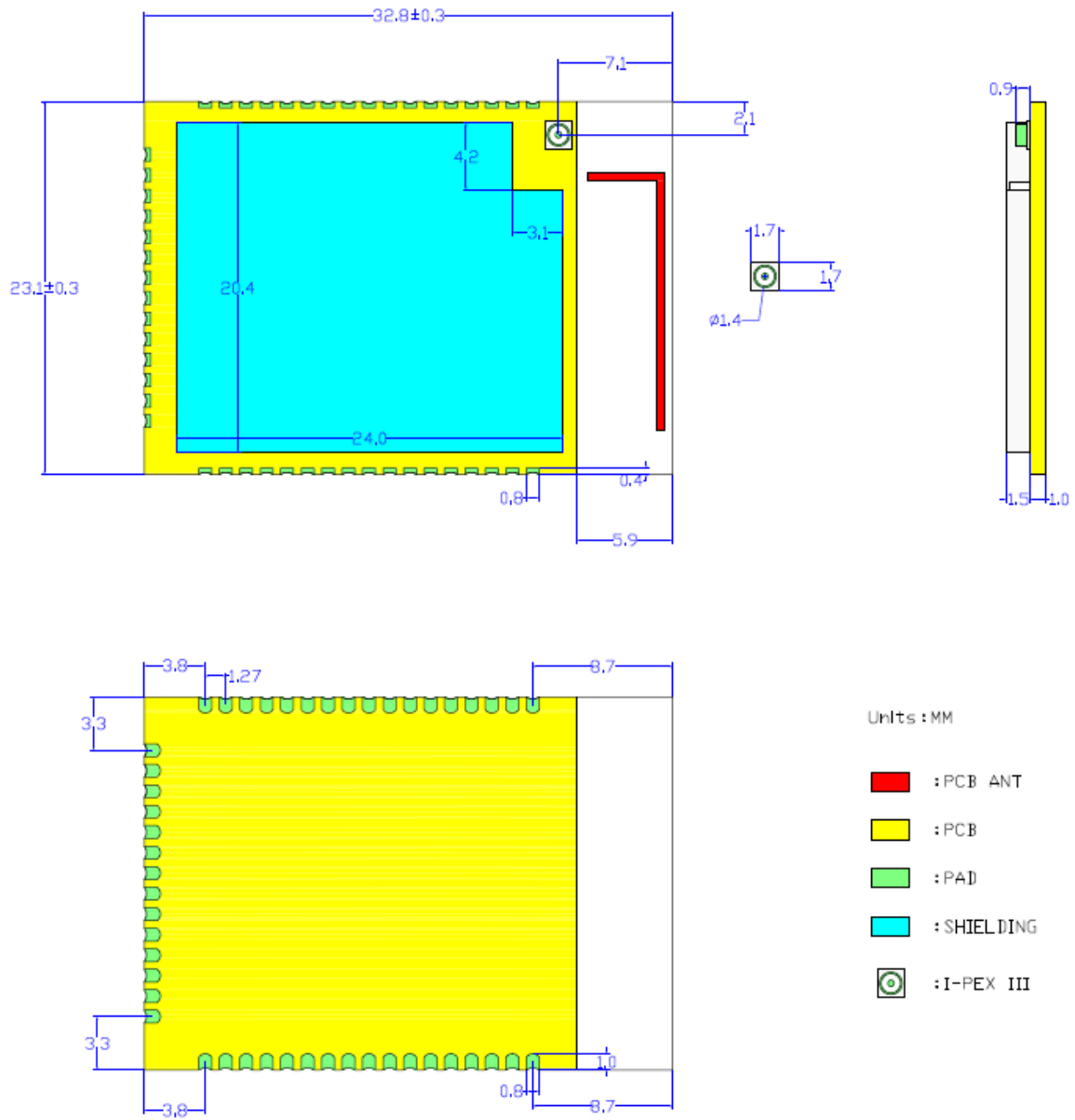

Figure 7. HF-LPD100-1 and -0 Mechanical Dimension

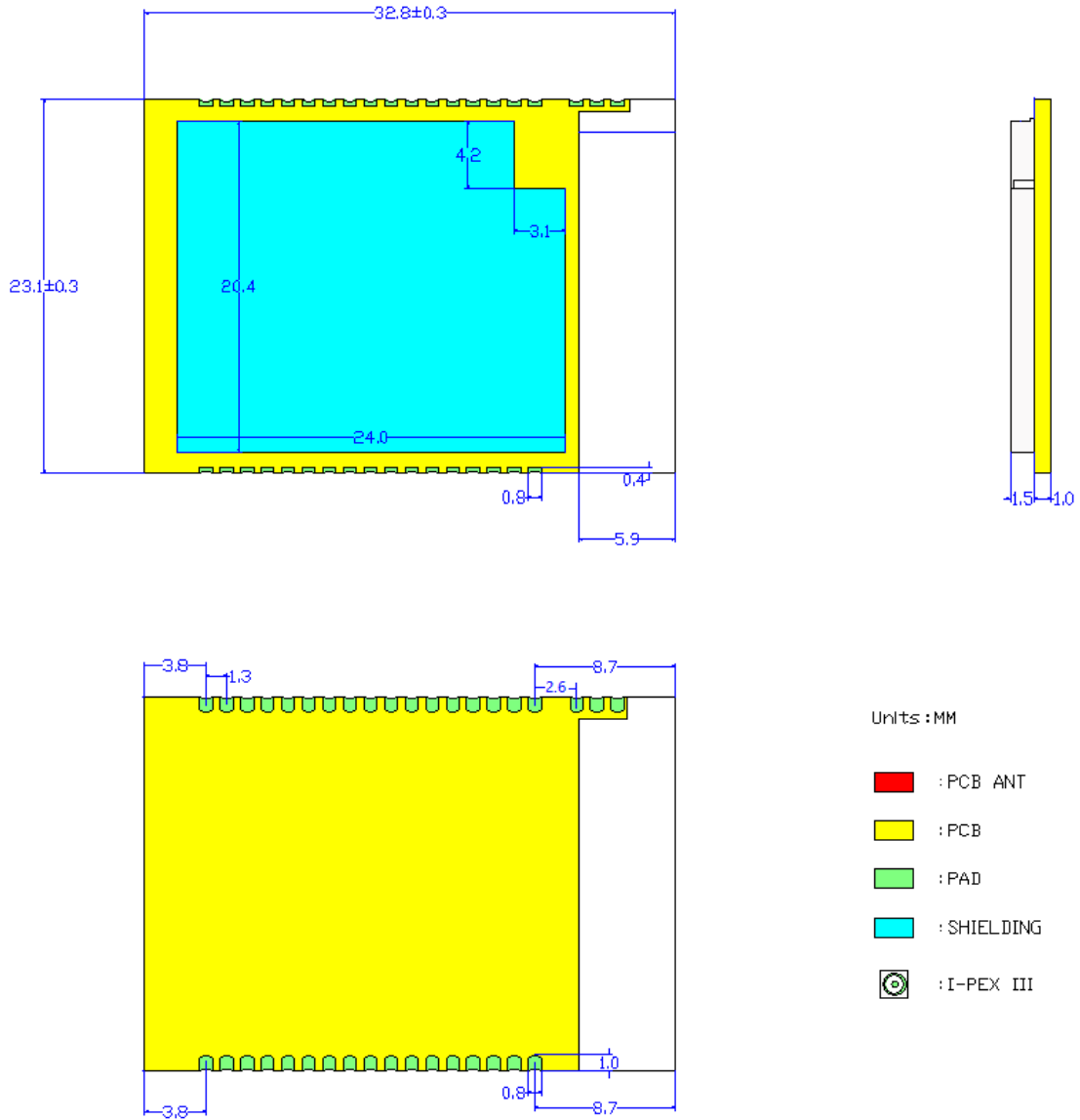

Figure 8. HF-LPD100-2 Mechanical Dimension

1.2.5. HF-LPD130 Mechanical Size

HF-LPD130 modules physical size (Unit: mm) as follows:

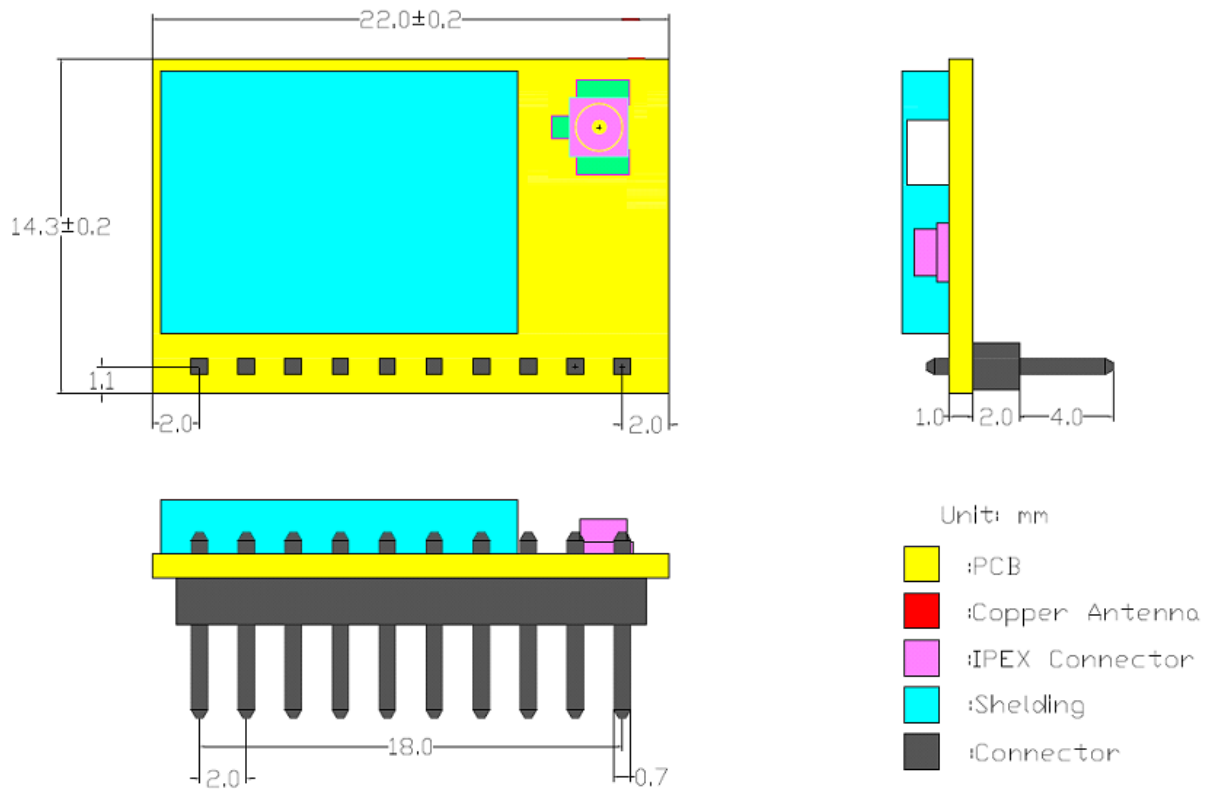

Figure 9. HF-LPD100 Mechanical Dimension

1.2.6. HF-LPD100 On-board PCB Antenna

HF-LPD100 module support internal on-board PCB antenna option. When customer select internal antenna, you shall comply with following antenna design rules and module location suggestions:

- For customer PCB, RED color region (8.3x18.4mm) can't put componet or paste GND net;
- Antenna must away from metal or high components at least 10mm;
- Antenna can't be shielded by any metal enclosure;

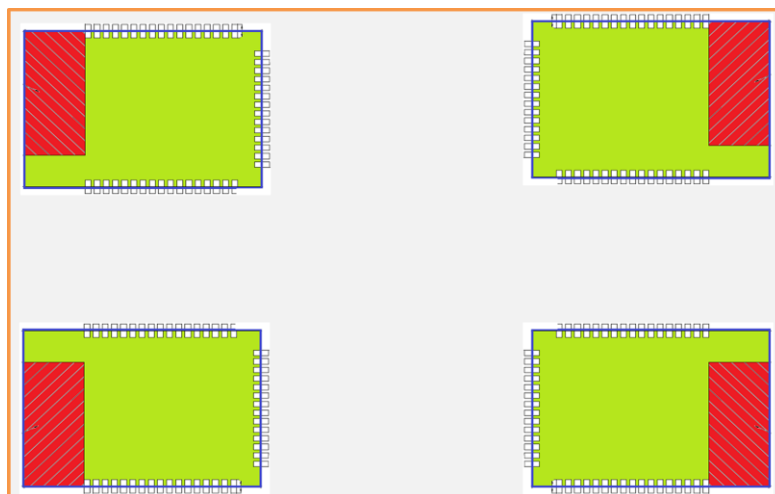

Figure 10. Suggested Module Placement Region

High-Flying suggest module better locate in following region at customer board, which to reduce the effect to antenna and wireless signal, and better consult High-Flying technical people when you structure your module placement and PCB layout.

1.2.7. External Antenna

HF-LPD100 series module supports external antenna(I-PEX) option for user dedicated application. If user select external antenna, HF-LPD100 series Wi-Fi modules must be connected to the 2.4G antenna according to IEEE 802.11b/g/n standards. We can provide external antenna if needed. Contact with our salesman.

The antenna parameters required as follows:

Table6. HF-LPD100 External Antenna Parameters

Item	Parameters
Frequency range	2.4/5GHz
Impedance	50 Ohm
VSWR	2 (Max)
Return Loss	-10dB (Max)
Connector Type	I-PEX or populate directly

1.2.8. Evaluation Kit

High-Flying provides the evaluation kit to promote user to familiar the product and develop the detailed application. The evaluation kit shown as below, user can connect to HF-LPD100 series module with the RS-232 UART, USB (Internal USB to UART convetor) or Wireless interface to configure the parameters, manage the module or do the some functional tests.

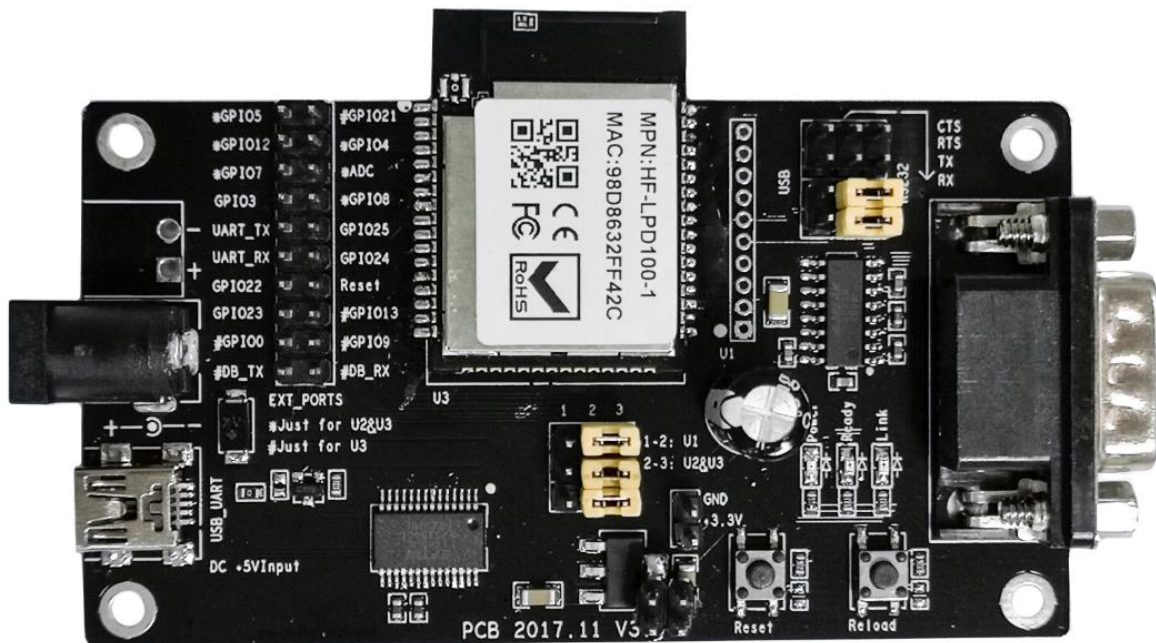

Figure 11. HF-LPD100 EVK

Notes: User need download USB to UART port driver from High-Flying web or contact with technical support people for more detail.

The external interface description for evaluation kit as follows:

Table7. HF-LPD100 Evaluation Kit Interface Description

Function	Name	Description
External Interface	RS232	Main data/command RS-232 interface
	USB	USB to UART interface, can be used for debug UART log
	DC5V	DC jack for power in, 5~9V input.
LED	Power	Power LED
	Ready	nReady LED
	Link	nLink LED
Button	nReload	Smartlink and Restore factory default configuration. See more for PIN Definition

1.2.9. Order Information

Base on customer detailed requirement, HF-LPD100 series modules provide different variants and physical type for detailed application.

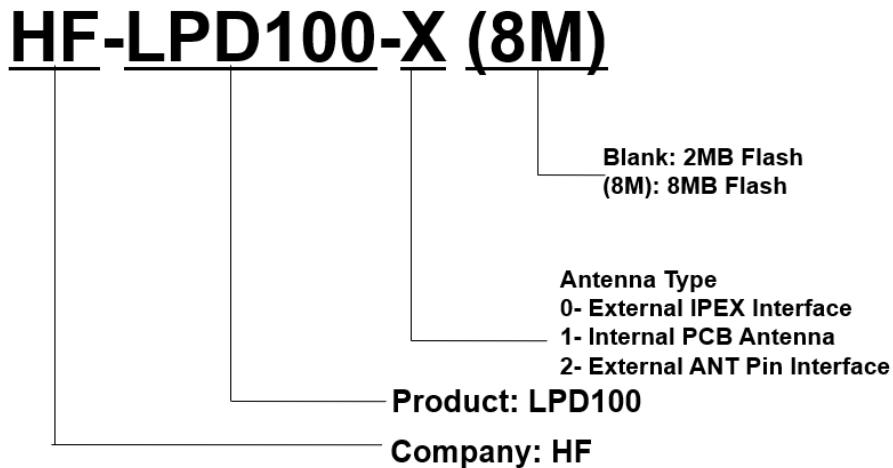

Figure 12. HF-LPD100 Order Information

HF-LPD130-XX

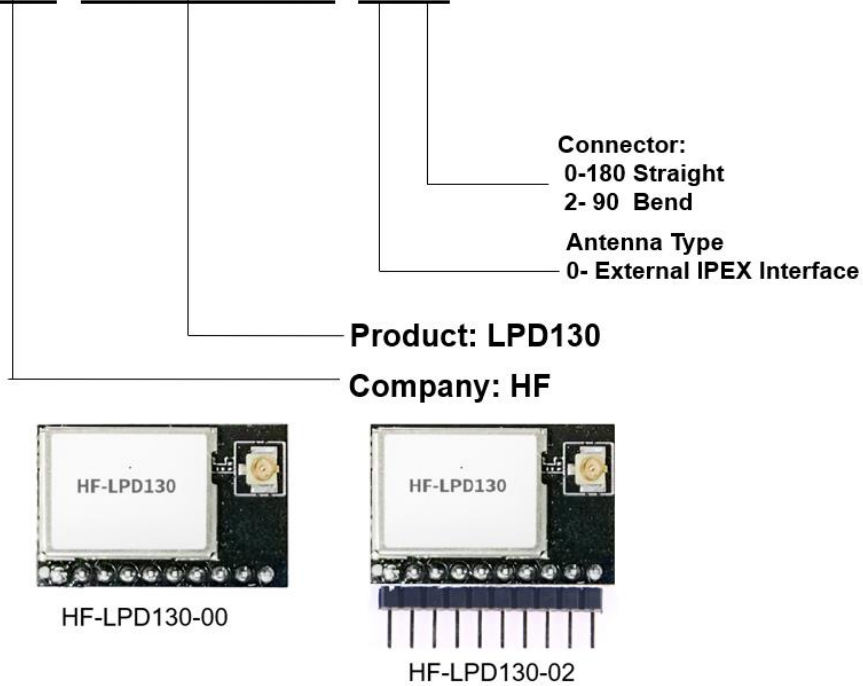

Figure 13. HF-LPD130 Order Information

1.2.10. Hardware Typical Application

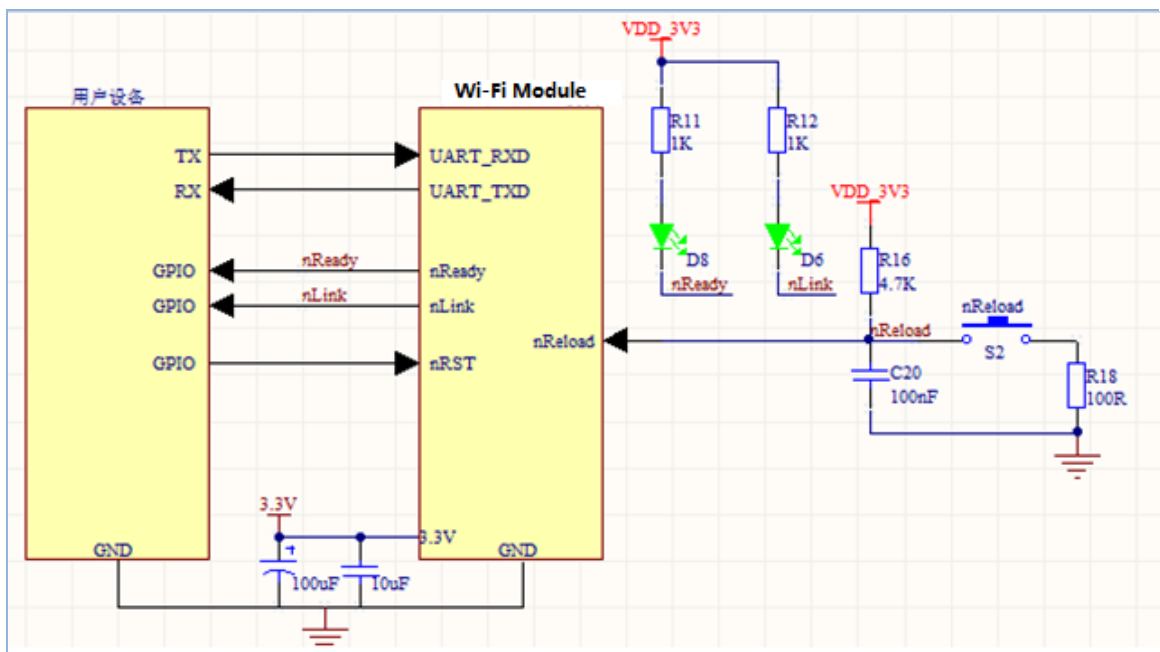

Figure 14. HF-LPD100 Hardware Typical Application

Notes:

nReset- Module hardware reset signal. Input. Logics “0” effective.

There is pull-up resistor internal and no external pull-up required. When module power up or some issue happened, MCU need assert nRST signal "0" at least 10ms, then set "1" to keep module fully reset.

nLink- Module WIFI connection status indication. Output.

(This pin is recommend to connect to LED, indicate status when the module in wireless upgrade mode)

When module connects to AP (AP associated), this pin will output "0". This signal used to judge if module already at WiFi connection status. There is pull-up resistor internal and no external pull-up required. If nLink function not required, can leave this pin open.

nReady- Module boot up ready signal. Output. Logics "0" effective.

The module will output "0" after normal boot up. This signal used to judge if module finish boot up and ready for application or working at normal mode. If nReady function not required, can leave this pin open.

nReload- Module restore to factory default configuration. Input. Logics "0" effective.

(This pin is recommend to connect to button, is used to enter wireless upgrade mode)

User can de-assert nReload signal "0" more than 4s through button or MCU pin, then release, module will restore to factory default configuration and re-start boot up process.. If nReload function not required, can leave this pin open.

UART0_TXD/RXD- UART port data transmit and receive signal.

2. FUNCTIONAL DESCRIPTION

2.1. Wireless Networking

HF-LPD100 module can be configured as both wireless STA and AP base on network type. Logically there are two interfaces in HF-LPD100. One is for STA, and another is for AP. When HF-LPD100 works as AP, other STA equipments are able to connect to HF-LPD100 module directly. Wireless Networking with HF-LPD100 is very flexible.

Notes:

AP: that is the wireless Access Point, the founder of a wireless network and the centre of the network nodes. The wireless router we use at home or in office may be an AP.

STA: short for Station, each terminal connects to a wireless network (such as laptops, PDA and other networking devices) can be called with a STA device.

2.1.1. Basic Wireless Network Based On AP

Infrastructure: it's also called basic network. It built by AP and many STAs which join in.

The characters of network of this type are that AP is the centre, and all communication between STAs is transmitted through the AP. The figure following shows such type of networking.

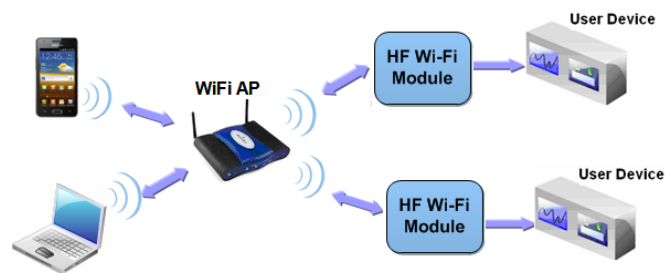

Figure 15. HF-LPD100 Basic Wireless Network Structure

2.1.2. Wireless Network Based On STA

HF-LPD100 module support STA network mode.

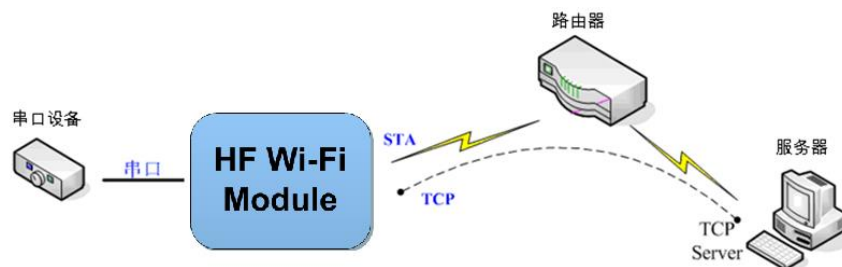

Figure 16. HF-LPD100 STA Network Structure

2.2. Work Mode : Transparent Transmission Mode

HF-LPD100 module support serial interface transparent transmission mode. The benefit of this mode is achieves a plug and play serial data port, and reduces user complexity furthest. In this mode, user should only configure the necessary parameters. After power on, module can automatically connect to the default wireless network and server.

As in this mode, the module's serial port always work in the transparent transmission mode, so users only need to think of it as a virtual serial cable, and send and receive data as using a simple serial. In other words, the serial cable of users' original serial devices is directly replaced with the module; user devices can be easy for wireless data transmission without any changes.

The transparent transmission mode can fully compatible with user's original software platform and reduce the software development effort for integrate wireless data transmission.

The parameters which need to configure include:

- **Wireless Network Parameters**
 - Wireless Network Name (SSID)
 - Security Mode
 - Encryption Key
- **TCP/UDP Linking Parameters**
 - Protocol Type
 - Link Type (Server or Client)
 - Target Port ID Number
 - Target Port IP Address
- **Serial Port Parameters**
 - Baud Rate
 - Data Bit
 - Parity (Check) Bit
 - Stop Bit
 - Hardware Flow Control

2.3. Encryption

Encryption is a method of scrambling a message that makes it unreadable to unwanted parties, adding a degree of secure communications. There are different protocols for providing encryption, and the HF-LPD100 module supports following:

- ◆ WEP
- ◆ WPA-PSK/TKIP
- ◆ WPA-PSK/AES
- ◆ WPA2-PSK/TKIP
- ◆ WPA2-PSK/AES

2.4. Parameters Configuration

HF-LPD100 module supports two methods to configuration parameters: **AT+instruction set**.

AT+instruction set configuration means user configure parameters through serial interface command. Refer to “AT+instruction set” chapter for more detail.

2.5. Firmware Update

HF-LPD100 module supports multiple upgrade methods:

- UART upgrade
- Local Network upgrade

2.6. SOCKET B Function

HF-LPD100 support double socket communication, the socket B function is disabled by default.

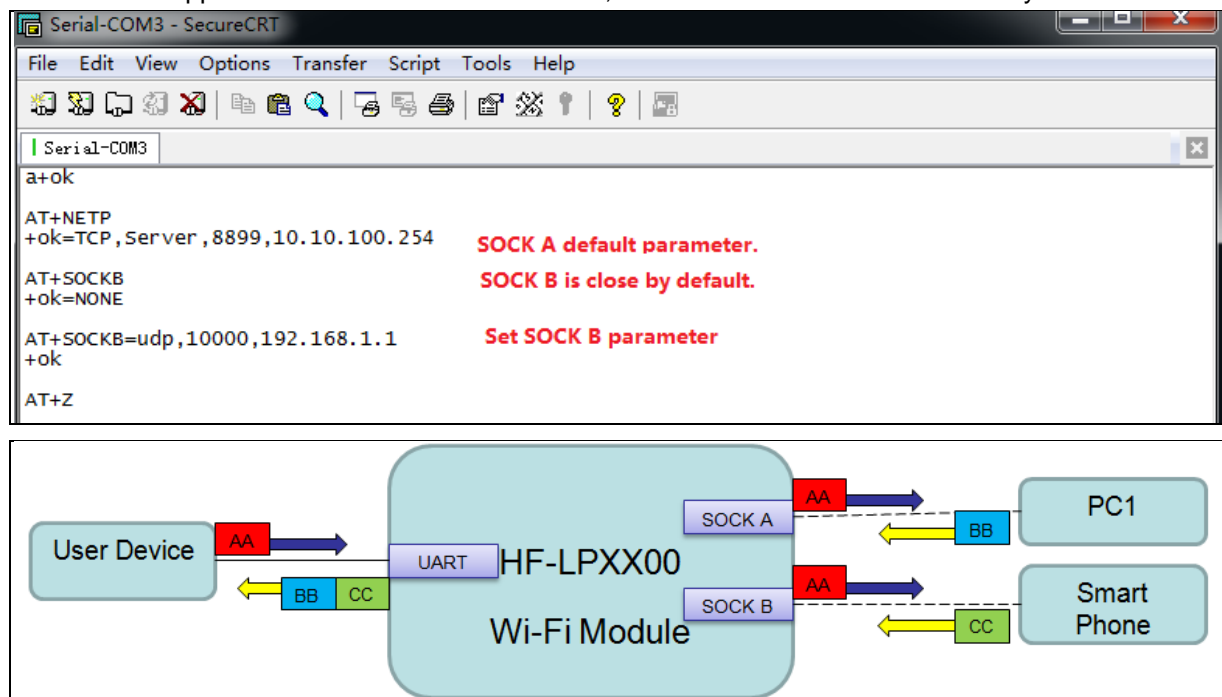

Figure 17. Socket B function demo

2.7. Multi-TCP Link Connection

When HF-LPD100 module SOCK A configured as TCP Server, it supports Multi-TCP link connection, and maximum 5 TCP clients permitted to connect to HF-LPD100 module. User can realize multi-TCP link connection at each work mode.

Multi-TCP link connection will work as following structure:

Upstream: All dates from different TCP connection or client will be transmitted to the serial port as a sequence.

Downstream: All data from serial port (user) will be replicate and broadcast to every TCP connection or client.

Detailed multi-TCP link data transmission structure as following figure:

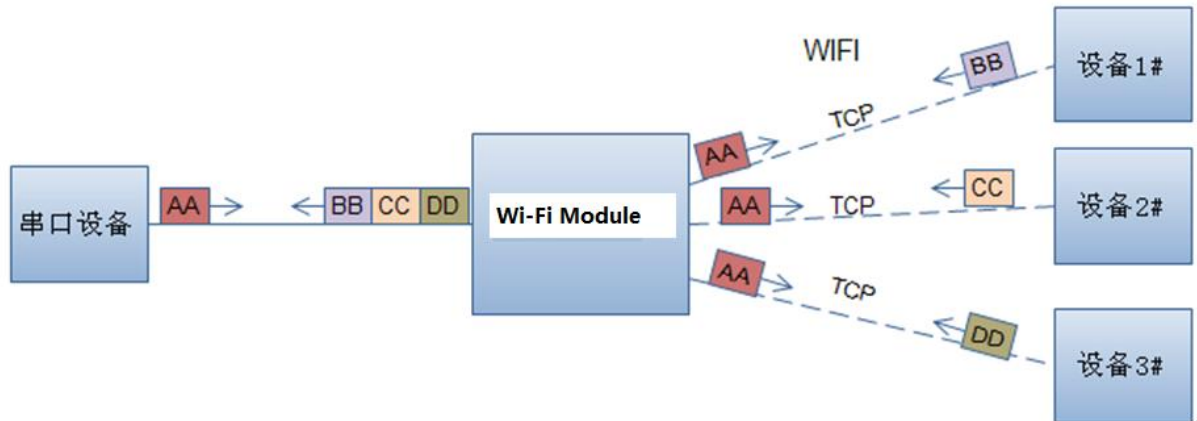

Figure 18. Multi-TCP Link Data Transmission Structure

2.8. 2.4GHz and 5GHz Dual Band

Module support dual band(AT+WFREQ command), if the router 2.4G and 5G AP SSID is the same. The module will connect to the AP with better signal strength. The following picture is the signal strength queue sorted by signed strength. The first column is channel, 1~13 is 2.4G channel, 36~165 is 5G channel.

2.4 G communication distance is better than 5G. But sigal disturbance is worse than 5G. Too much device works in 2.4G will cause fail to connect and data lost. This module can set to working in 5G, make better communication quality.

```

AT+WSCAN
+ok=
ch_ssid_bssid_security_indicator
6,Soneter1,78:44:FD:26:9A:7C,WPAPSKWPA2PSK/AES,100
11,OULUN_TEST,7C:B5:40:4F:B2:CD,OPEN/NONE,100
9,LBLINK,3C:33:00:A8:35:2C,WPAPSKWPA2PSK/AES,100
10,hope_14:75:90:B5:BE:3A,WPAPSKWPA2PSK/AES,100
161,Soneter1_5G,78:44:FD:26:9A:7E,WPAPSKWPA2PSK/AES,100
10,wx-114,28:2C:B2:D2:E5:96,OPEN/NONE,100
11,UPGRADE-AP_aaaa,C8:3A:35:54:B3:70,WPA2PSK/AES,100
11,LLJ,14:75:90:B6:A2:E6,WPAPSKWPA2PSK/AES,92
149,ChinaNet-xuanyin,78:44:FD:AB:73:78,WPAPSKWPA2PSK/AES,92
1,yongheng,00:0E:E8:B6:57:2C,WPA2PSK/AES,88
1,hf_group,70:AF:6A:CE:1F:A3,WPA2PSK/AES,84
11,ChinaNet-xuanyin,78:44:FD:AB:73:76,WPAPSKWPA2PSK/AES,84
4,uniriho_xc,D8:C8:E9:32:A1:E8,WPAPSKWPA2PSK/TKIPAES,82
13,xiaomi_jiehui,50:64:2B:CE:05:45,WPAPSKWPA2PSK/TKIPAES,80
4,ABC,14:75:90:0B:C6:96,WPA2PSK/AES,80
1,hello,AC:07:5F:E4:32:A0,WPA2PSK/AES,78
    
```

Figure 19. AP Scan result



Figure 20. 2.4G Environment

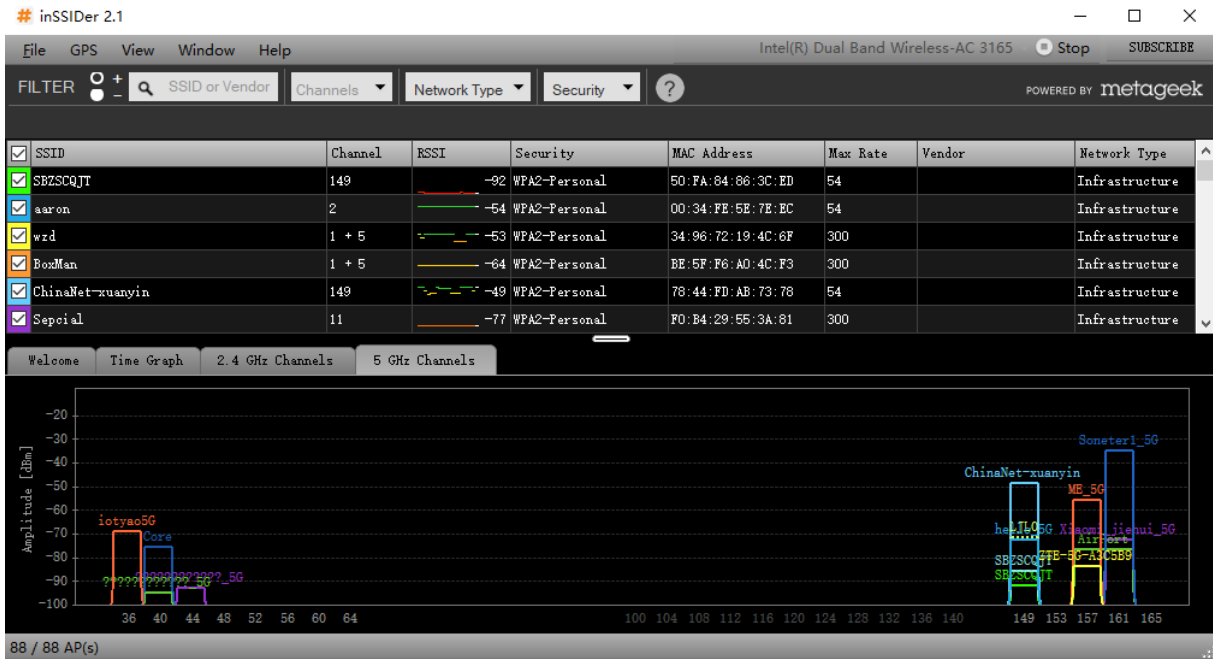

Figure 21. 5G Environment

3. OPERATION GUIDELINE

3.1. Configuration

When first use HF-LPD100 series modules, user may need some configuration. User can connect to HF-LPD100 module's wireless interface with following default setting information and configure the module through laptop.

Table8. HF-LPD100 Web Access Default Setting

Parameters	Default Setting
SSID	HF-LPD100
IP Address	10.10.100.254
Subnet Mask	255.255.255.0
Account	admin
Password	admin

3.1.1. Open Web Management Interface

There is internal webpage and external webpage in modules. The external webpage is for web management. The internal webpage is only for upgrading. But the internal webpage is the same.

- Step 1: Connect laptop to SSID "HF-LPT230" of HF-LPT230 module via wireless LAN card;
 Step 2: After wireless connection OK. Open Wen browser and access "<http://10.10.100.254>";
 Step 3: Then input user name and password in the page as following and click "OK" button.



Figure 22. Open Web Management page

The HF-LPD100 web management page support English and Chinese language. User can select language environment at the top right corner and click "Apply" button.

The main menu include nine pages: "System", "Work Mode", "STA Setting", "AP Setting", "Other Setting", "Account", "Upgrade SW", "Restart", "Restore".

3.1.2. System Page

At this page, user can check current device's important information and status such as: device ID (MID), software version, wireless work mode and related Wi-Fi parameters.

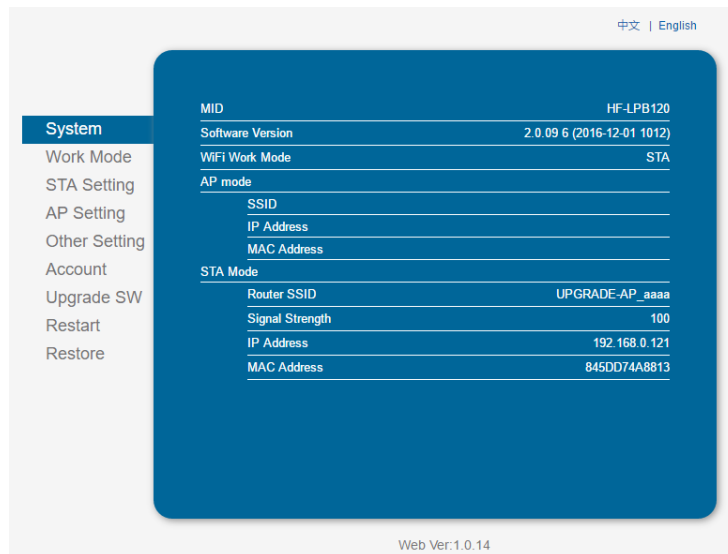

Figure 23. System Web Page

3.1.3. Work Mode Page

HF-LPD100 module can works at AP mode to simplify user's configuration, can also works at STA to connect remote server through AP router.

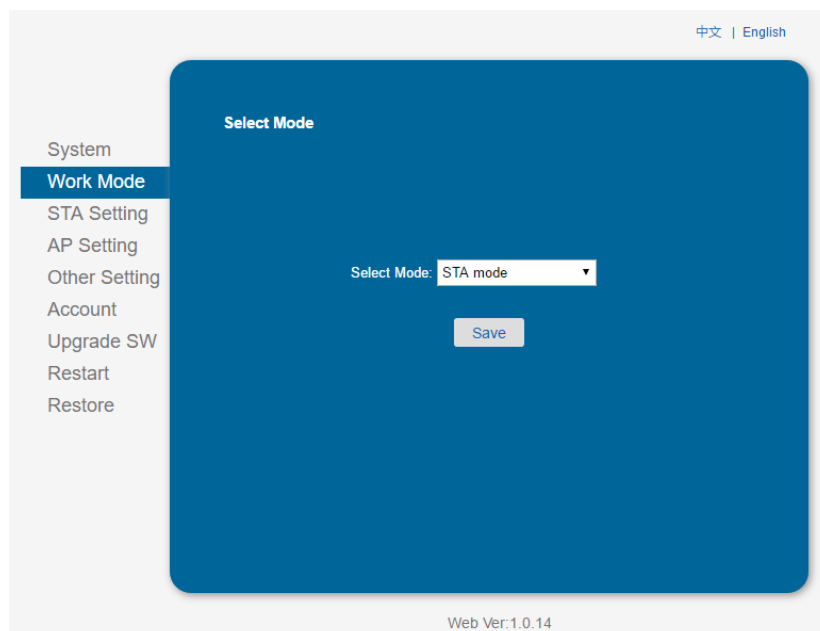

Figure 24. Work Mode Page

3.1.4. STA Setting Page

User can push “Scan” button to auto search Wi-Fi AP router nearby, and can connect with associate AP through some settings. Please note the encryption information input here must be fully same with Wi-Fi AP router’s configuration, and then it can link with AP correctly.

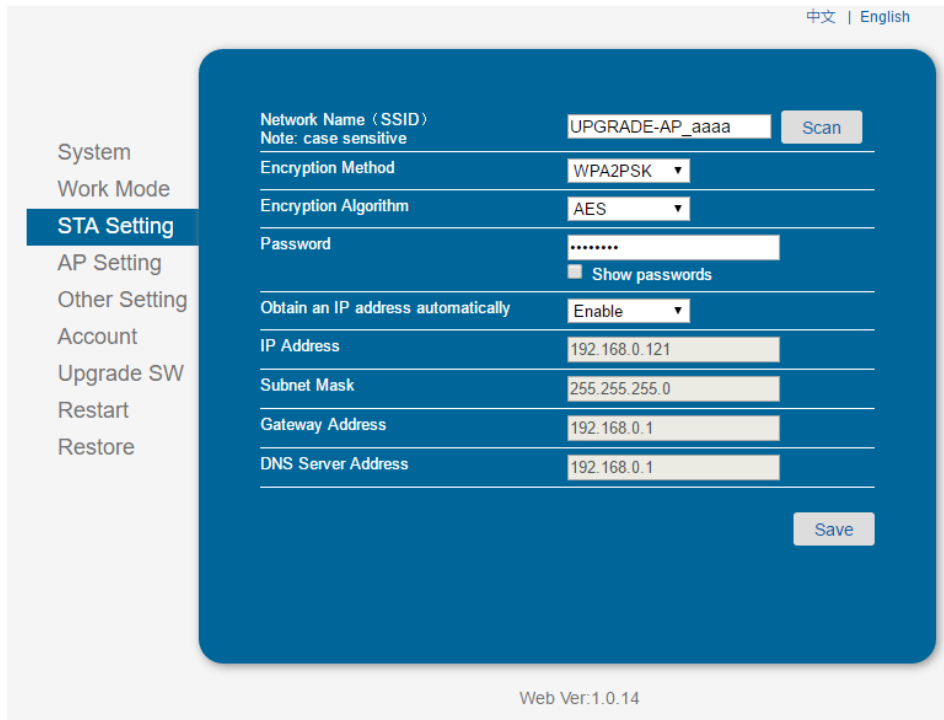

Figure 25. STA Setting Page

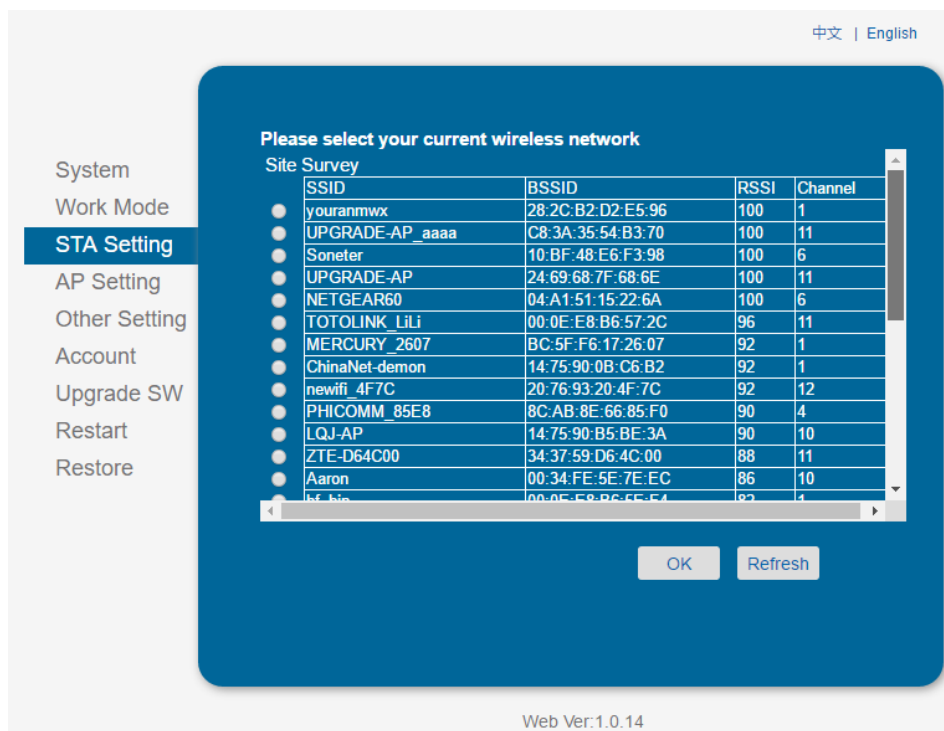

Figure 26. STA Scan Page

3.1.5. AP Setting Page

When user select module works at AP and AP+STA mode, then need setting this page and provide wireless and network parameters. Most of the system support DHCP to achieve IP address, so we suggest to “Enable” DHCP server in most applications.

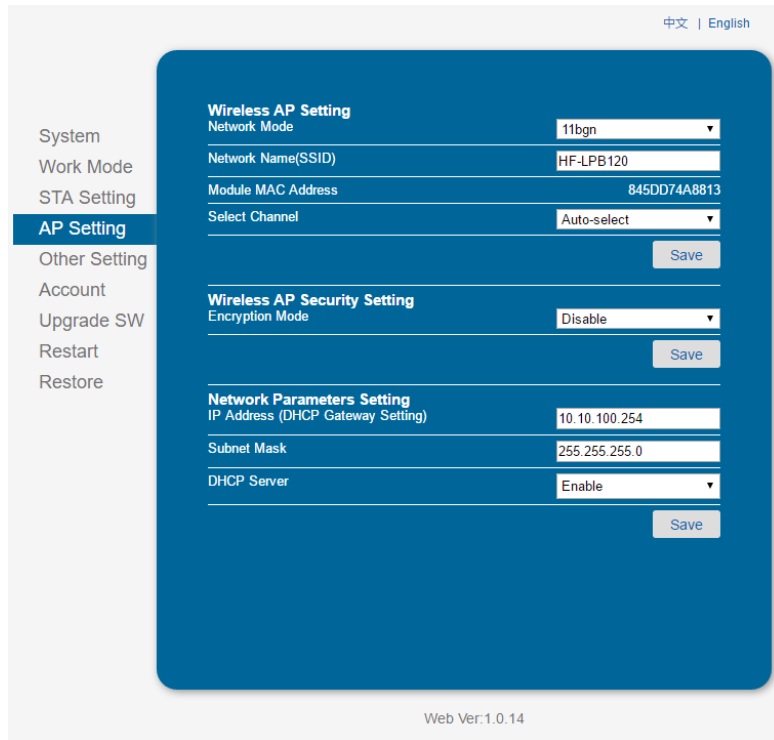

Figure 27. AP Setting Page

3.1.6. Other Setting Page

HF-LPD100 usually works at data transparent transmission mode. At this mode, the user device which connected with HF-LPD100 will connect and communicate with remote PC or server. At this page, user need setting serial port communication parameters and defines TCP related protocol parameters.

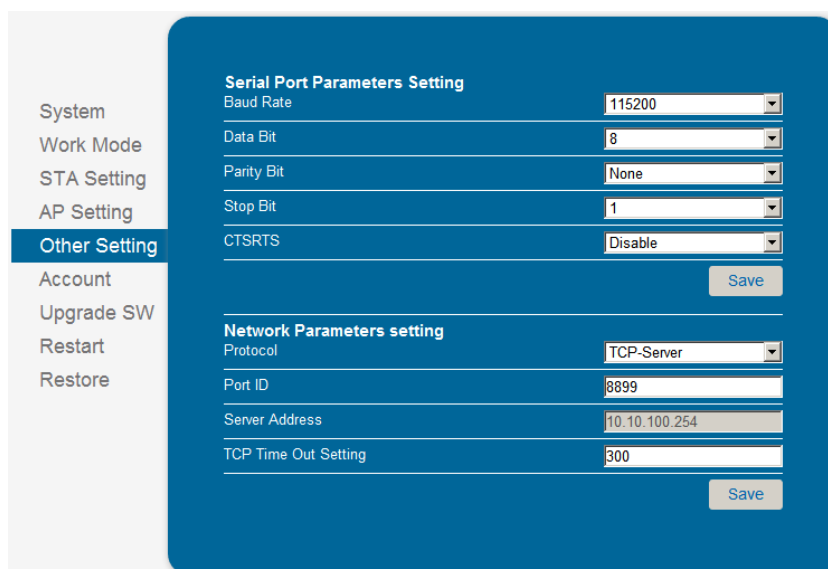

Figure 28. Other Setting Page

3.1.7. Account Management Page

This page set web server’s user name and password.

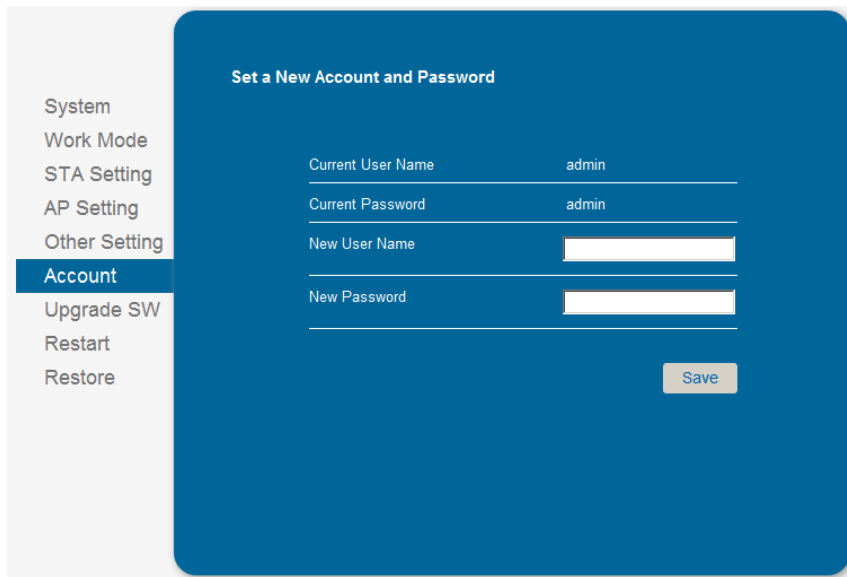

Figure 29. Account Page

3.1.8. Upgrade Software Page

User can upgrade new software (firmware) version through Wi-Fi. After upgrade success, need reboot it manually before new firmware valid.

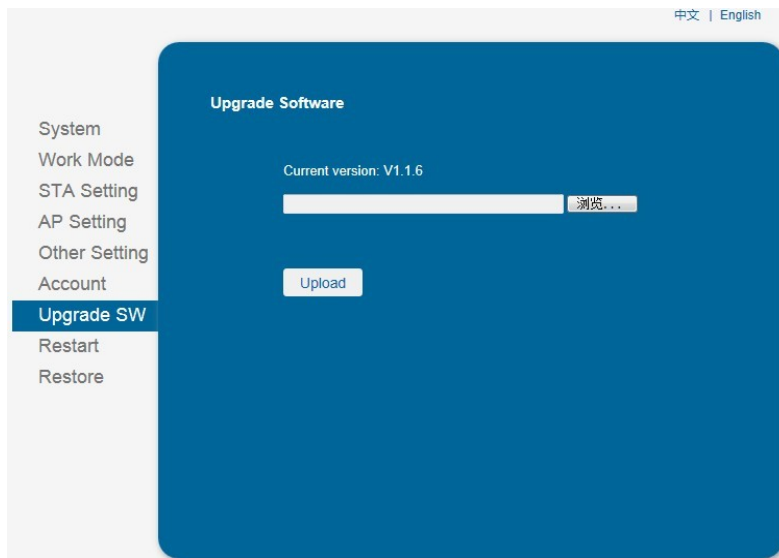

Figure 30. Upgrade SW page

3.1.9. Restart Page

Most of the setting and configuration can only effective after system restart. User shall restart after finish all setting.

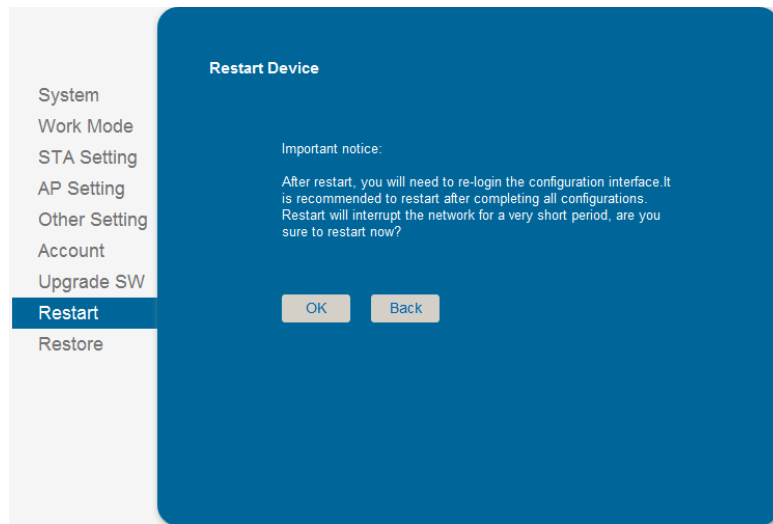

Figure 31. Restart Page

3.1.10. Restore Page

After module restore factory default setting, all user configuration profile will lose.

User can access <http://10.10.100.254> to set again, and user name and password is “admin”. HF-LPD100 will restore to AP mode for factory default setting.

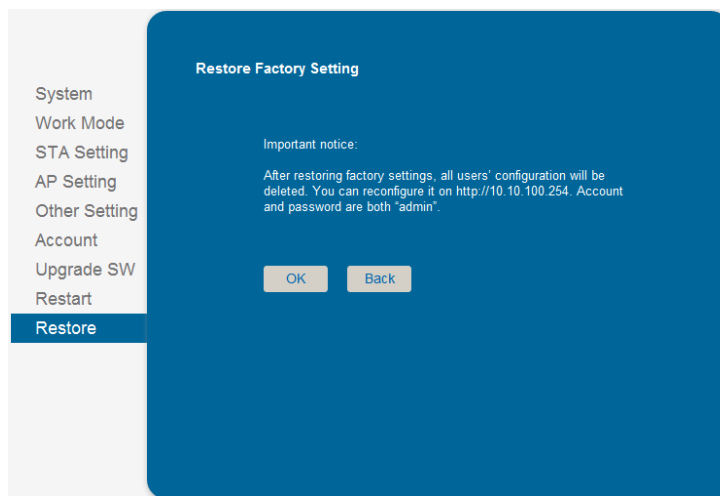

Figure 32. Restore Page

3.1.11. Internal Webpage

After wireless connection is OK. Open Wen browser and access “<http://10.10.100.254/iweb.html>”; It is for upgrading application and external webpage..

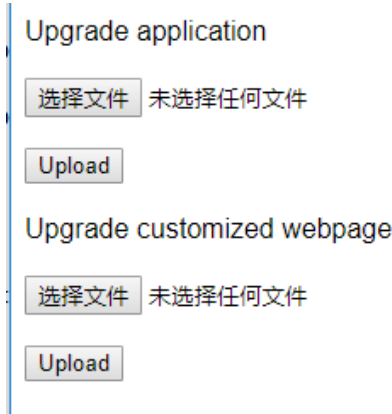



Figure 33. Internal Webpage

3.2. Usage Introduction

3.2.1. Software Debug Tools

High-Flying use two common software tools debugging and applying HF-LPD100 module. (User can also select other tools used to debug serial port).

- Serial Debugging Software: ComTools  **ComTools.exe**
- Ethernet Debugging Software: TCPUDPDbg  **TCPUDPDbg.exe**

3.2.2. Network Connection

User can select two methods to connect HF-LPD100 module base on dedicated application.

- **Use HF-LPD100 STA interface.** HF-LPD100 and debug PC2 connect to a wireless AP, another PC1 (or user device) connect to HF-LPD100 module with serial port:



Figure 34. STA Interface Debug Connection

- **Use HF-LPD100 AP interface.** Debug PC2 connect to HF-LPD100 through wireless connection, another PC1 (or user device) connect to HF-LPD100 module with serial port.



Figure 35. AP Interface Debug Connection

3.2.3. Default Parameter Setting

- Default SSID: HF-LPD100;

- Deault security mode: open,none;
- User UART parameter setting:115200,8,1,None;
- Default network parameter setting:TCP,Server,8899,10.10.100.254;
- Module IP address: dhcp,0.0.0.0,0.0.0.0,0.0.0.0;

3.2.4. Module Debug

PC1 open “CommTools” program, setting the same serial port parameters with HF-LPD100 module and open serial port connection.

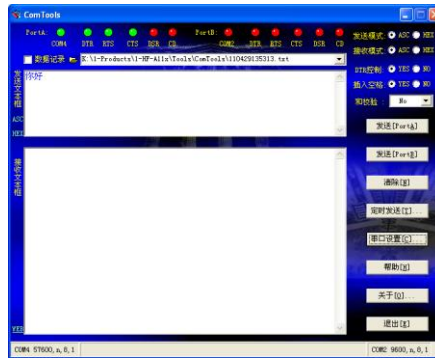

Figure 36. “CommTools” Serial Debug Tools

PC2 open “TCPUDPDbg” program, and create a new connection. If HF-LPD100 configured as Server mode, “TCPUDPDbg” Tools shall create “Client” mode connection. Or otherwise, create a “Server” mode connection.

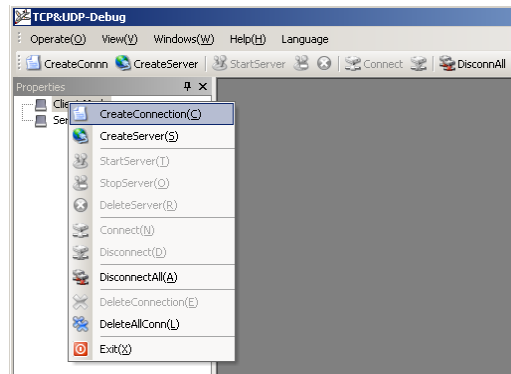

Figure 37. “TCPUDPDbg” Tools Create Connection

Then setting the TCP/UDP connection parameters. Default as following:

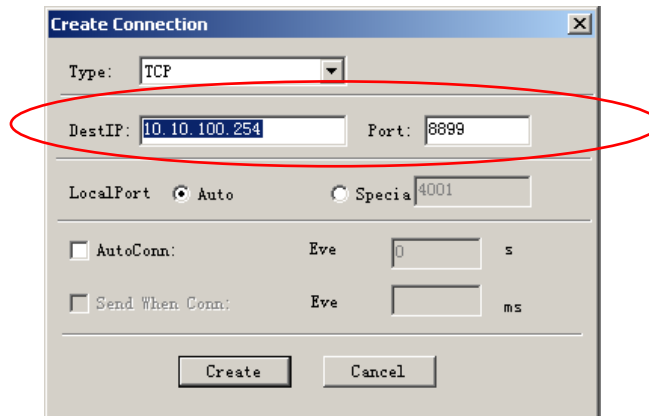

Figure 38. “TCPUDPDbg” Tools Setting

Then, click “Create” button to create a connection.

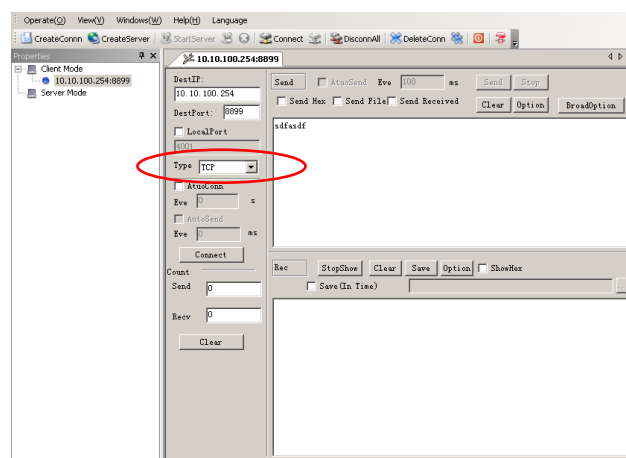

Figure 39. “TCPUDPDbg” Tools Connection

Now, in transparent transmission mode, data can be transferred from “CommTools” program to “TCPUDPDbg” program, or in reverse. You can see data in receiver side will keep same as in sender side.

3.3. Typical Application Examples

3.3.1. Wireless Control Application



Figure 40. Wireless Control Application

For this wireless control application, HF-LPD100 works as AP mode. Module’s serial port connects to user device. So, control agent (Smart phone for this example) can manage and control the user device through the wireless connection with HF-LPD100 module.

3.3.2. Remote Management Application

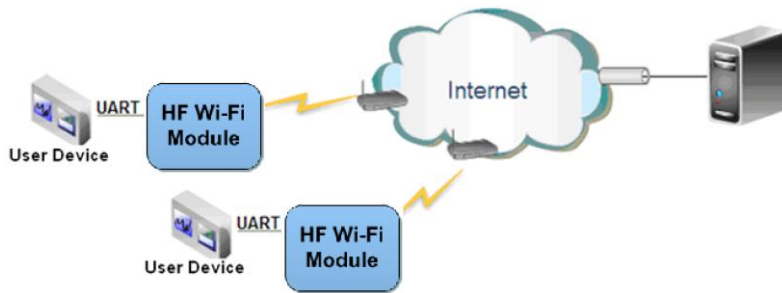

Figure 41. Remote Management Application

For this remote management application, HF-LPD100 works as STA mode and connects to Internet through wireless AP. Module configured as TCP Client and communicates with remote TCP server at Internet. Module’s serial port connects to user device.

So, user device’s data or sampling information can send to remote TCP server for storage or processing. Also remote TCP server can send command to control and manage the user device through the wireless network.

3.3.3. Transparent Serial Port Application

For this transparent serial port application, two HF-LPD100 modules connect as below figures to build up a transparent serial port connection. One HF-LPD100 works as AP mode, another HF-LPD100 works as STA mode. Make the STA device connects to AP.



Figure 42. Transparent Serial Port Application

4. AT+INSTRUCTION INTRODUCTION

4.1. Configuration Mode

When HF-LPD100 power up, it will default works as transparent transmission mode, then user can switch to configuration mode by serial port command. HF-LPD100 UART default parameters setting as below figure,

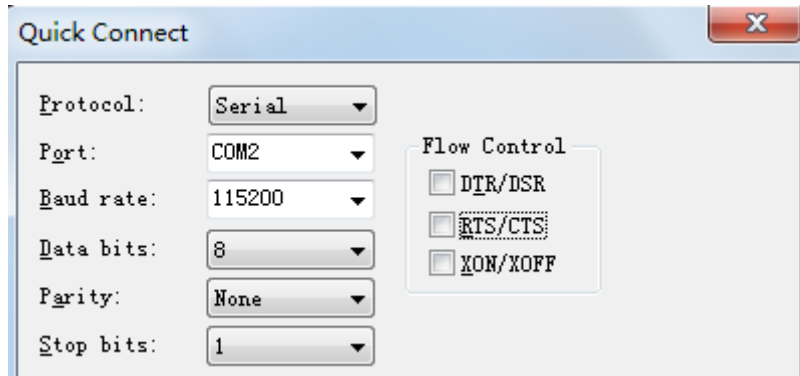

Figure 43. HF-LPD100 Default UART Port Parameters

In configuration mode, user can setting the module through AT+instruction set, which cover all web page setting function.

4.1.1. Switch to Configuration Mode

Two steps to finish switching from transparent transmission mode to configuration mode.

- **UART input “+++”, after module receive “+++”, and feedback “a” as confirmation.**
- **UART input “a”, after module receive “a” and feedback “+ok” to go into AT+instruction set configuration mode.**

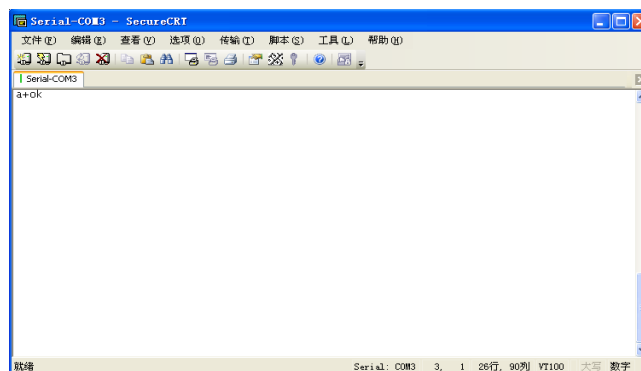
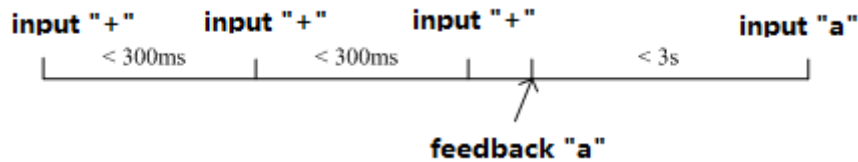

Figure 44. Switch to Configuration Mode

Notes:

1. When user input “+++” (No “Enter” key required), the UART port will display feedback information “a”, and not display input information “+++” as above UART display.

2. Any other input or wrong step to UART port will cause the module still works as original mode (transparent transmission).
3. “+++” and “a” should be input in a certain period of time to make the module switch to configuration mode. Like the following sequence.



4.1.2. Send AT Command in Transparent Transmission Mode

After set AT+CMDPW command value, the module support response AT command for special data format as “prefix”+“AT comman”+“\r”, it is very useful for query some status in transparent transmission mode. It saves the steps of changing to AT command mode.

The following example, we first set AT+CMDPW=HF, then send the following data in transparent mode, and get the AT command response. This data won't be sent to socket.

The screenshot shows a serial terminal window with two panes. The left pane shows the ASCII view of the received data: "HFAT+WMODE=STA". The right pane shows the HEX view of the received data: "48 46 41 54 2B 57 4D 4F 44 45 3D 53 54 41 0D". A red box highlights the "0D" value in the HEX view, with a red text annotation: "Note this 0x0d command end data".

4.2. AT+Instruction Set Overview

User can input AT+Instruction through hyper terminal or other serial debug terminal, also can program the AT+Instruction to script. User can also input “AT+H” to list all AT+Instruction and description to start.

AT+H
+ok

AT+: NONE command, reply "+ok".
 AT+ASWD: Set/Query WiFi configuration code.
 AT+E: Echo ON/off, to turn on/off command line echo function.
 AT+ENTM: Goto Through Mode.
 AT+NETP: Set/Get the Net Protocol Parameters.
 AT+UART: Set/Get the UART Parameters.
 AT+UARTF: Enable/disable UART AutoFrame function.
 AT+UARTFT: Set/Get time of UART AutoFrame.
 AT+UARTFL: Set/Get frame length of UART AutoFrame.
 AT+UARTTE: Set/Query UART free-frame trigger time between two byte.
 AT+PING: General PING command.
 AT+WAP: Set/Get the AP parameters.
 AT+WKEY: Set/Get the Security Parameters of WIFI AP Mode.
 AT+WMODE: Set/Get the WIFI Operation Mode (AP or STA).
 AT+WSKEY: Set/Get the Security Parameters of WIFI STA Mode.
 AT+WSSID: Set/Get the AP's SSID of WIFI STA Mode.
 AT+WSLK: Get Link Status of the Module (Only for STA Mode).
 AT+WSQL: Get Link Quality of the Module (Only for STA Mode).
 AT+WSCAN: Get The AP site Survey (only for STA Mode).
 AT+WEBU: Set/Get the Login Parameters of WEB page.
 AT+TCPK: Get The state of TCP link.
 AT+TCPTO: Set/Get TCP time out.
 AT+TCPDIS: Connect/Dis-connect the TCP client link
 AT+RCV: Rcv data from UART
 AT+SEND: Send data to UART
 AT+WANN: Set/Get The WAN setting if in STA mode.
 AT+LANN: Set/Get The LAN setting if in ADHOC mode.
 AT+RELD: Reload the default setting and reboot.
 AT+RLDEN: Put on/off the GPIO12.
 AT+Z: Reset the Module.
 AT+MID: Get The Module ID.
 AT+VER: Get application version.
 AT+H: Help.

Figure 45. "AT+H" Instruction for Help

4.2.1. Instruction Syntax Format

AT+Instruction protocol is based on the instruction of ASCII command style, the description of syntax format as follow.

- **Format Description**
 - < >: Means the parts must be included
 - []: Means the optional part

- **Command Message**

AT+<CMD>[op][para-1,para-2,para-3,para-4...]<CR>

- AT+: Prefix of command message;
- CMD: Command string;
- [op]: Symbol of command operator,
 - ◆ "=" : The command requires parameters input;
 - ◆ "NULL": Query the current command parameters setting;
- [para-n]: Parameters input for setting if required;
- <CR>:"Enter" Key, it's 0x0a or 0x0d in ASCII;

Notes: When input AT+Instruction, "AT+<CMD>" character will display capital letter automatic and other_parts will not change as you input.

- **Response Message**

+<RSP>[op] [para-1,para-2,para-3,para-4...]<CR><LF><CR><LF>

- +: Prefix of response message;
- RSP: Response string;
 - ◆ “ok” : Success
 - ◆ “ERR”: Failure
- [op] : =
- [para-n]: Parameters if query command or Error code when error happened;
- <CR>: ASCII 0x0d;
- <LF>: ASCII 0x0a;

➤ **Error Code**

Table9. Error Code Description

Error Code	Description
-1	Invalid Command Format
-2	Invalid Command
-3	Invalid Operation Symbol
-4	Invalid Parameter
-5	Operation Not Permitted

4.2.2. AT+Instruction Set

Table10. AT+Instruction Set List

Instruction	Description
<null>	NULL
Management Instruction Set	
E	Open/Close show back function
WMODE	Set/Query Wi-Fi work mode (AP/STA)
ENTM	Set module into transparent transition mode
TMODE	Set/Query module data transfer mode
MID	Query module ID information
VER	Query module software version information
BVER	Query Bootloader version
HWVER	Query Wi-Fi chip hardware version
RELD	Restore to factory default setting
FCLR	Erase factory setting
Z	Re-start module
H	Help
Configure Parameters Instruction Set	
CFGTF	Copy User Parameters to Factory Default Parameters
UART Instruction Set	
UART	Set/Query serial port parameters
Network Instruction Set	
PING	Network "Ping" Instruction
NETP	Set/Query SOCKA network protocol parameters
MAXSK	Set/Query SOCKA TCP Client connection number
TCPLK	Query if SOCKA TCP link already build-up

Instruction	Description
TCPTO	Set/Query SOCKA TCP timeout
TCPDIS	Open/Close SOCKA TCP link
SEND	Send Data at Command Mode
RECV	Receive Data at Command Mode
SOCKB	Set/Query SOCKB parameters
TCPDISB	Open/Close SOCKB TCP link
TCPTOB	Set/Query SOCKB TCP timeout
TCPLKB	Query if SOCKB TCP link already build-up
SNDB	Send data to SOCKB in Command Mode
RCVB	Receive data from SOCKB in Command Mode
Wi-Fi STA Instruction Set	
WSKEY	Set/Query STA security parameters
WSSID	Set/Query associated AP SSID parameters
WANN	Set/Query STA's network parameters
WSMAC	Set/Query module MAC address
WSLK	Query STA Wi-Fi link status
WSLQ	Query STA Wi-Fi signal strength
WSCAN	Scan AP
Wi-Fi AP Instruction Set	
LANN	Set/Query AP's network parameters
WAP	Set/Query AP Wi-Fi parameters
WAKEY	Set/Query AP security parameters
WADHCP	Set/Query AP DHCP Server status
WALK	Query MAC address of STA device connecting to module AP
WALKIND	Enable/Disable indication of connection status.
WAPMXSTA	Set/Query max STA devices supported for AP.
Remote Upgrade Instruction Set	
OTA	Upgrade Firmware
UPURL	Set/Query remote upgrade URL address
Webpage Set	
PLANG	Set/Query webpage language
WEBU	Set/Query webpage login account
Others Instruction Set	
WRMID	Set module ID
ASWD	Set/Query WiFi configuration code
SMTLK	Start SmartLink function
NDBG	Set UART debug information
SMEM	Query RAM malloc status
WIFI	Enable/Disable Wi-Fi
WFREQ	Set Wi-Fi frequency mode
SMARTAPCONFIG	Config SmartAPLink function
SMARTAPSTART	Start SmartAPLink function

4.2.2.1. AT+E

- Function: Open/Close show back function;
- Format:
 - ◆ Set Operation

AT+E=<status><CR>

+ok<CR><LF><CR><LF>

- Parameters:
 - ◆ status: Echo status
 - ◇ on: Open echo
 - ◇ off: Close echo

When HF-LPD100 module firstly switch from transparent transmission to configuration mode, show back status is open, input “AT+E” to close show back function, input“AT+E” again to open show back function, use AT+E=on/off command to save the echo status.

4.2.2.2. AT+CMDPW

- Function: Set/Query AT command prefix character for sending AT command in throughput mode. Setting is valid after reset;

- Format:

- ◆ Query Operation

AT+CMDPW<CR>

+ok=<data><CR><LF><CR><LF>

- ◆ Set Operation

AT+CMDPW=<data><CR>

+ok<CR><LF><CR><LF>

- Parameters:

- ◆ mode: Default is blank for disable t 是 his function. The maximum is 20 chacter length, once has been set, the AT command in transparent transmission mode function is enabled (AT+H and AT+WSCAN are not supported). Do restore to factory operation to disable and clear the

When set this value to “HF”, then can get response of “+ok=STA”(Hex: 2B 6F 6B 3D 53 54 41) for send “HFAT+WMODE\r”(Hex: 48 46 41 54 2B 57 4D 4F 44 45 0D, AT command should end with 0D or 0A).

4.2.2.3. AT+WMODE

- Function: Set/Query Wi-Fi work mode. Setting is valid after reset;

- Format:

- ◆ Query Operation

AT+WMODE<CR>

+ok=<mode><CR><LF><CR><LF>

- ◆ Set Operation

AT+WMODE=<mode><CR>

+ok<CR><LF><CR><LF>

- Parameters:

- ◆ mode:Wi-Fi work mode
 - ◇ AP
 - ◇ STA
 - ◇ APSTA

4.2.2.4. AT+ENTM

- Function: Set module into transparent transmission mode;

- Format:

AT+ENTM<CR>

+ok<CR><LF><CR><LF>

When operate this command, module switch from configuration mode to transparent transmission mode.

4.2.2.5. AT+TMODE

- Function: Set/Query module data transfer mode. Setting is valid after reset.

- Format:

- ◆ Query Operation

AT+TMODE<CR>

+ok=<tmode><CR><LF><CR><LF>

- ◆ Set Operation

AT+TMODE=<tmode><CR>

+ok<CR><LF><CR><LF>

- Parameters:

- ◆ tmode: data transfer mode, include:
 - ✧ throughput: throughput mode
 - ✧ cmd: command mode

4.2.2.6. AT+MID

- Function: Query module ID information;

- Format:

- ◆ Query Operation

AT+MID<CR>

+ok=<module_id><CR><LF><CR><LF>

- Parameters:

- ◆ module_id: Module ID information;
 - ✧ HF-LPD100;

Notes: User can set this parameter through AT+WRMID.

4.2.2.7. AT+VER

- Function: Query module software version information;

- Format:

- ◆ Query Operation

AT+VER<CR>

+ok=<ver><CR><LF><CR><LF>

- Parameters:

- ◆ ver: Module software version information;

4.2.2.8. AT+RELD

- Function: module restore to factory default setting;

- Format:

- ◆ Set Operation

AT+RELD<CR>

+ok=rebooting...<CR><LF><CR><LF>

When operate this command, module will restore to factory default setting and reboot.

4.2.2.9. AT+FCLR

- Function: Erase factory setting;
- Format:
 - ◆ Query Operation

AT+FCLR<CR>

+ok=<status><CR><LF><CR><LF>

4.2.2.10. AT+Z

- Function: Re-start module;
- Format:

AT+Z<CR>

4.2.2.11. AT+H

- Function: Help;
- Format:
 - ◆ Query Operation

AT+H<CR>

+ok=<command help><CR><LF><CR><LF>

- Parameters:
 - ◆ command help: command introduction;

4.2.2.12. AT+CFGTF

- Function: Copy User Parameters to Factory Default Parameters;
- Format:
 - ◆ Query Operation

AT+CFGTF<CR>

+ok=<status><CR><LF><CR><LF>

- Parameters:
 - ◆ status: feedback operation status;

4.2.2.13. AT+UART

- Function: Set/Query serial port parameters. Setting is valid after reset.
- Format:
 - ◆ Query Operation

AT+UART[=uart_num]<CR>

+ok=<baudrate,data_bits,stop_bit,parity,flowctrl><CR><LF><CR><LF>

- ◆ Set Operation

AT+UART=<baudrate,data_bits,stop_bit,parity,flowctrl>[,uart_num]<CR>

+ok<CR><LF><CR><LF>

- Parameters:
 - ◆ uart_num: UART Channel, the default is UART0.
 - 0: UART0 Channel

- ◆ baudrate:
 - ◇ 4800,9600,19200,38400,57600,115200,230400,380400,460800,921600
- ◆ data_bits:
 - ◇ 8
- ◆ stop_bits:
 - ◇ 1
- ◆ parity:
 - ◇ NONE
 - ◇ EVEN
 - ◇ ODD
- ◆ Flowctrl: (CTSRTS)
 - ◇ NFC: No hardware flow control
 - ◇ **FC: hardware flow control(Not support yet)**

4.2.2.14. AT+PING

- Function: Network “PING” Instruction.
- Format:
 - ◆ Set Operation

```
AT+PING=<ip[,count,size]><CR>
+ok=<sta><CR><LF><CR><LF>
```
- Parameters:
 - ◆ ip: ip address or domain name.
 - ◆ count: Ping command execute count times. Default is 1.
 - ◆ size: Ping packet size. Default is 32 bytes.
 - ◆ sta: feedback result
 - ◇ Success
 - ◇ Timeout
 - ◇ Unknown host

4.2.2.15. AT+NETP

- Function: Set/Query SOCKA network protocol parameters. Setting is valid immediately.
- Format:
 - ◆ Query Operation

```
AT+NETP<CR>
+ok=<protocol,CS,port,IP><CR><LF><CR><LF>
```
 - ◆ Set Operation

```
AT+NETP=<protocol,CS,port,IP><CR>
+ok<CR><LF><CR><LF>
```
- Parameters:
 - ◆ protocol:
 - ◇ TCP
 - ◇ UDP
 - ◆ CS: Network mode:

- ◇ SERVER

- ◇ CLIENT

- ◆ Port: protocol port ID: Decimal digit and less than 65535

- ◆ IP: Server's IP address when module set as client

If set as UDP SERVER, the module will save the IP address and port of the latest UDP packet received. The data will be sent to the saved IP address and port. If the module hasn't saved any IP address and port when power up. The data will be sent to the IP address and port which is set by this command.

If set as UDP,CLIENT, the data will always be sent to the IP address and port set by this command.

4.2.2.16. AT+MAXSK

- Function:Set/ Query SOCKA TCP Client connection number.

- Format:

- ◆ Query Operation

```
AT+MAXSK<CR>
```

```
+ok=<num><CR><LF><CR><LF>
```

- ◆ Set Operation

```
AT+MAXSK=<num><CR>
```

```
+ok<CR><LF><CR><LF>
```

- Parameters:

- ◆ num: TCP Client connection number. Range: 1~5. 5 is the default value it means when the module work in TCP server , it accepts max 5 TCP client connect to it.

4.2.2.17. AT+TCPLK

- Function: Query if SOCKA TCP link already build-up;

- Format:

```
AT+TCPLK<CR>
```

```
+ok=<sta><CR><LF><CR><LF>
```

- Parameters:

- ◆ sta.: if module already setup TCP link;

- ◇ on: TCP link setup;

- ◇ off: TCP link not setup;

4.2.2.18. AT+TCPTO

- Function: Set/Query SOCKA TCP timeout; Setting is valid after reset.

- Format:

- ◆ Query Operation

```
AT+TCPTO<CR>
```

```
+ok=<time><CR><LF><CR><LF>
```

- ◆ Set Operation

```
AT+TCPTO=<time ><CR>
```

```
+ok<CR><LF><CR><LF>
```

- Parameters:

- ◆ time: TCP timeout time.
 - ◇ ≤ 600, (600s);
 - ◇ ≥ 0, (0 means no timeout);
 - ◇ Default, 300s;

Module begin to count time when TCP channel don't receive any data, clecherar time counter when TCP channel receive any data. If the time counter reaches the TCPTO, the tcp channel will be break. If the module work in TCP Client, it will connect the TCP server instantly and when the module work in TCP Server, the TCP client device should make the connection itself.

4.2.2.19. AT+TCPDIS

- Function: Open/Close SOCKA TCP link;
- Format:
 - ◆ Query Opera

AT+TCPDIS<CR>

+ok=<sta><CR><LF><CR><LF>

- ◆ Set Operation

AT+TCPDIS =<on/off><CR>

+ok<CR><LF><CR><LF>

- Parameters:

When query, sta.: Feedback if TCP Client can be link,

- ◇ On, TCP link close
- ◇ off, TCP link on

When setting, "off" means close TCP link. After finish this command, module disconnect TCP link and not connect again. "On" means open TCP link. After finish this command, module re-connect TCP server right away.

4.2.2.20. AT+SEND

- Function: Send Data to SOCKA at Command Mode.
- Format:

AT+SEND=<data_lenth><CR>

+ok<CR><LF><CR><LF>

- Parameters:

- ◆ data_lenth: Lenth of send data. Range: 0~1000 Byte

The UART port will wait 3 seconds for input after this command is sent OK. The data received from UART port is sent to SOCKA. If the interval of two bytes is more than 10ms, the data will be sent instantly.

4.2.2.21. AT+RECV

- Function: Receive Data from SOCKA at Command Mode.
- Format:

AT+RECV=<data_lenth><CR>

+ok=< data_lenth, data_content><CR><LF><CR><LF>

- Parameters:

- ◆ data_lenth: Lenth of receive data. Range: 0~1000 Byte
- ◆ data_content: contents of receive data.

If not receive any data in 3 second, then feedback +ok=0.

4.2.2.22. AT+SOCKB

- Function: Set/Query SOCKB parameters. Setting is valid immediately.
- Format:
 - ◆ Query Operation

AT+SOCKB<CR>

+ok=<protocol,port,IP><CR><LF><CR><LF>

- ◆ Set Operation

AT+SOCKB=<protocol,port,IP><CR>

+ok<CR><LF><CR><LF>

- Parameters:
 - ◆ Protocol: Protocol type:
 - ◇ TCP: Only for TCP Client
 - ◇ UDP: UDP Client
 - ◇ UDPS: UDP Server
 - ◆ Port: Protocol Port in decimal, less than 65535
 - ◆ IP: Destination IP address, domain name is support

If set as UDP SERVER, the module will save the IP address and port of the latest UDP packet received. The data will be sent to the saved IP address and port. If the module hasn't saved any IP address and port when power up. The data will be sent to the IP address and port which is set by this command.

If set as UDP,CLIENT, the data will always be sent to the IP address and port set by this command.

4.2.2.23. AT+TCPDISB

- Function: Open/Close SOCKB connection
- Format:
 - ◆ Query Operation

AT+TCPDISB<CR>

+ok=<sta><CR><LF><CR><LF>

- ◆ Set Operation

AT+TCPDISB =<on/off><CR>

+ok<CR><LF><CR><LF>

- Parameters:

When setting, "off" means close TCP link. After finish this command, module disconnect TCP link and not connect again. "On" means open TCP link. After finish this command, module re-connect TCP server right away.

4.2.2.24. AT+TCPTOB

- Function: Set/Query Operation SOCKB TCP timeout. Setting is valid after reset.
- Format:

- ◆ Query Operation

AT+TCPTOB<CR>

+ok=<time><CR><LF><CR><LF>

- ◆ Set Operation

AT+TCPTOB=<time ><CR>

+ok<CR><LF><CR><LF>

- Parameters

- ◆ Time: TCP timeout

- ◇ ≤ 600:600s
- ◇ ≥ 0:0 means no timeout
- ◇ Default:300s

If the SOCKB TCP don't receive any data from TCP server for TCP tmeout setting, the module will break and reconnect the TCP server. If it receive data from server, the timeout counter will be clear.

4.2.2.25. AT+TCPLKB

- Function:Query SOCKB connection status

- Format:

AT+TCPLKB<CR>

+ok=<sta><CR><LF><CR><LF>

- Parameters:

- ◆ sta.: SOCKB connection status

- ◇ on: TCP connected
- ◇ off: TCP disconnected

4.2.2.26. AT+SNDB

- Function: Send datas to SOCKB at Command Mode

- Format:

AT+SNDB=<data_lenth ><CR>

+ok<CR><LF><CR><LF>

- Parameters:

- ◆ data_lenth: Lenth of send data. Range: 0~1000 Byte

The UART port will wait 3 seconds for input after this command is sent OK. The data received from UART port is sent to SOCKB. If the interval of two bytes is more than 10ms, the data will be sent instantly.

4.2.2.27. AT+RCVB

- Function: Receive datas from SOCKB at Command Mode

- Format:

AT+RCVB=<data_lenth><CR>

+ok=< data_lenth, data_content><CR><LF><CR><LF>

- Parameters:

- ◆ data_lenth: Lenth of receive data. Range: 0~1000 Byte
- ◆ data_content: contents of receive data.

If not receive any data in 3 second, then feedback +ok=0.

4.2.2.28. AT+UDPLCPT

- Function: Set/Query UDP local port of Socket A and Socket B..

- Format:

- ◆ Query Operation

AT+UDPLCPT<CR>

+ok=<porta,portb><CR><LF><CR><LF>

- ◆ Set Operation

AT+UDPLCPT=<porta,portb><CR>

+ok<CR><LF><CR><LF>

- Parameters

- ◆ porta: UDP local port of Socket A, 0: do not fix local UDP port.
- ◆ portb: UDP local port of Socket B, 0: do not fix local UDP port.

4.2.2.29. AT+WSSSID

- Function: Set/Query Wi-Fi associated AP SSID parameters. Setting is valid after reset.

- Format:

- ◆ Query Operation

AT+WSSSID<CR>

+ok=<ap's ssid><CR><LF><CR><LF>

- ◆ Set Operation

AT+WSSSID=<ap's ssid ><CR>

+ok<CR><LF><CR><LF>

- Parameters:

- ◆ ap's ssid: AP's SSID (Within 32 character);

4.2.2.30. AT+WSKEY

- Function: Set/Query STA security parameters. Setting is valid after reset.

- Format:

- ◆ Query Operation

AT+WSKEY<CR>

+ok=<auth,encry,key><CR><LF><CR><LF>

- ◆ Set Operation

AT+WSKEY=< auth,encry,key><CR>

+ok<CR><LF><CR><LF>

- Parameters:

- ◆ auth: Authentication mode
 - ◇ OPEN
 - ◇ SHARED
 - ◇ WPAPSK
 - ◇ WPA2PSK
- ◆ encry:Encryption algorithm
 - ◇ NONE: When "auth=OPEN", effective

- ✧ WEP-H: When “auth=OPEN” or “SHARED”, effective, in HEX format
- ✧ WEP-A: When “auth=OPEN” or “SHARED”, effective, in ASCII format
- ✧ TKIP: When “auth= WPAPSK” or “WPA2PSK”, effective
- ✧ AES: When “auth= WPAPSK” “WPA2PSK”, effective
- ◆ key: password. When encry is WEP-H, password is in HEX format, password length is 10 or 26. When encry is WEP-A, password is in ASCII format, password length is 5 or 13. When encry is TKIP or AES, password is in ASCII code, password length shall be 8~63.

4.2.2.31. AT+WANN

- Function: Set/Query STA network setting. Setting is valid after reset.

- Format:

- ◆ Query Operation

AT+WANN<CR>

+ok=<mode,address,mask,gateway><CR><LF><CR><LF>

- ◆ Set Operation

AT+WANN=< mode,address,mask,gateway ><CR>

+ok<CR><LF><CR><LF>

- Parameters:

- ◆ mode: STA's IP network setting
 - ✧ static: Static IP
 - ✧ DHCP: Dynamic IP
- ◆ address: STA IP address;
- ◆ mask: STA subnet mask;
- ◆ gateway: STA gateway address;

4.2.2.32. AT+WSMAC

- Function: Set/Query Module STA MAC address parameters. Setting is valid after reset.

- Format:

- ◆ Query Operation

AT+WSMAC<CR>

+ok=<mac_address><CR><LF><CR><LF>

- ◆ Set Operation

AT+WSMAC=<code,mac_address,key><CR>

+ok<CR><LF><CR><LF>

- Parameters:

- ◆ code: security code
 - ✧ 8888 (default value)
- ◆ Mac_address: module MAC address, such as ACCF23FF1234
- ◆ key: encryption key. It is not allowed to change, contact us if need to change MAC.

4.2.2.33. AT+WSLK

- Function: Query STA WiFi link status

- Format:

- ◆ Query Operation

AT+WSLK<CR>

+ok=<ret><CR><LF><CR><LF>

- Parameters:

- ◆ ret

- ◇ "Disconnected", if no WiFi connection;
- ◇ "AP' SSID (AP's MAC") , if WiFi connection available;

4.2.2.34. AT+WSQL

- Function: Query STA WiFi signal strength;

- Format:

- ◆ Query Operation

AT+WSQL<CR>

+ok=<ret><CR><LF><CR><LF>

- Parameters:

- ◆ ret

- ◇ "Disconnected", if no WiFi connection;
- ◇ "AP's WiFi signal strength" , if WiFi connection available;

4.2.2.35. AT+WSCAN

- Function: Scan AP, max show 50 item;

- Format:

AT+WSCAN<CR>

+ok=<ap_site><CR><LF><CR><LF>

- Parameters:

- ◆ ap_site: AP searched.

```
AT+WSCAN
+ok=
Ch,SSID,BSSID,security,Indicator
4,TP-LINK_686E,24:69:68:7F:68:6E,WPAPSKWPA2PSK/AES,100
7,Upd,7C:B5:40:4F:B2:CD,WPAPSKWPA2PSK/AES,100
5,UPGRADE-AP_aaaa,C8:3A:35:54:B3:70,WPA2PSK/AES,100
7,LBLINK,3C:33:00:A8:35:2C,WPAPSKWPA2PSK/AES,100
```

4.2.2.36. AT+LANN

- Function: Set/Query AP's network parameters. Setting is valid after reset.

- Format:

- ◆ Query Operation

AT+LANN<CR>

+ok=<ipaddress,mask><CR><LF><CR><LF>

- ◆ Set Operation

AT+LANN=< ipaddress,mask><CR>

+ok<CR><LF><CR><LF>

- Parameters:

- ◆ ipaddress: AP's IP address;
- ◆ mask: AP's net mask;

4.2.2.37. AT+WAP

- Function: Set/Query AP Wi-Fi parameters. Support maximum 5 STA connection. Setting is valid after reset.
- Format:
 - ◆ Query Operation

```
AT+WAP<CR>
+ok=<wifi_mode,ssid,channel><CR><LF><CR><LF>
```
 - ◆ Set Operation

```
AT+WAP =<wifi_mode,ssid,channel><CR>
+ok<CR><LF><CR><LF>
```
- Parameters:
 - ◆ wifi_mode: Wi-Fi mode, include:
 - ◇ 11B
 - ◇ 11BG
 - ◇ 11BGN (Default Value)
 - ◆ ssid:SSID at AP mode, the maximum length is 32.
 - ◆ channel: Wi-Fi channel selection:
 - ◇ AUTO;(Default CH1)
 - ◇ CH1~CH11;

4.2.2.38. AT+WAKEY

- Function: Set/Query AP Wi-Fi security parameters. Setting is valid after reset.
- Format:
 - ◆ Query Operation

```
AT+WAKEY<CR>
+ok=<auth,encry,key><CR><LF><CR><LF>
```
 - ◆ Set Operation

```
AT+WAKEY=< auth,encry,key><CR>
+ok<CR><LF><CR><LF>
```
- Parameters:
 - ◆ auth: include
 - ◇ OPEN
 - ◇ WPA2PSK
 - ◆ Encry: include
 - ◇ NONE: When “auth=OPEN” available;
 - ◇ AES: When “auth=WPA2PSK” available;
 - ◆ key: security code, ASCII code, 8~63 bytes.

4.2.2.39. AT+WADHCP

- Function: Set/Query AP DHCP server status; Setting is valid after reset.
- Format:
 - ◆ Query Operation

```
AT+WADHCP<CR>
+ok=<status>,<ip1>,<ip2><CR><LF><CR><LF>
```

◆ Set Operation

AT+WADHCP=<status>[,ip1,ip2]<CR>

+ok<CR><LF><CR><LF>

- Parameters:
 - ◆ status:AP's DHCP server function status:
 - ◇ on:DHCP Server Open;
 - ◇ off:DHCP Server Close;
 - ◆ ip1: DHCP allocate IP start value.
 - ◆ ip2: DHCP allocate IP end value.

4.2.2.40. AT+WALK

- Function: Query MAC address of STA device connecting to module AP
 - Format:
 - ◆ Query Operation
- AT+WALK<CR>**
- +ok=<status> <CR><LF><CR><LF>**
- Parameters:
 - ◆ status: MAC address of STA device connecting to module AP.
 - ◇ No Connection: No STA device connecting to module AP;

4.2.2.41. AT+WALKIND

- Function: Enable/Disable indication of module AP connection status.
 - Format:
 - ◆ Query Operation
- AT+WALKIND<CR>**
- +ok=<status> <CR><LF><CR><LF>**
- ◆ Set Operation
- AT+WALKIND=<status><CR>**
- +ok<CR><LF><CR><LF>**
- Parameters:
 - ◆ status: indication of module AP connection status.
 - ◇ on: Enable nLink indication function. When STA device connecting to module AP, nLink output Low, otherwise output High.
 - ◇ off: Disable nLink indication function. **(default mode)**.

4.2.2.42. AT+WAPMXSTA

- Function: Set/Query max STA number supported for AP.
 - Format:
 - ◆ Query Operation
- AT+WAPMXSTA<CR>**
- +ok=<num> <CR><LF><CR><LF>**
- ◆ Set Operation
- AT+WAPMXSTA=<num><CR>**
- +ok<CR><LF><CR><LF>**

- Parameters:
 - ◆ num: max STA number supported for AP.
 - ◇ 1~4: Support max 1~4 STA devices connects to module AP. **4 is default value for max 4 STA device supported.**

4.2.2.43. AT+MDCH

- Function: Set Wi-Fi Auto Switch Function. Setting is valid after reset.
- Format:
 - ◆ Query Operation

```
AT+MDCH<CR>
```

```
+ok=<mode><CR><LF><CR><LF>
```
 - ◆ Set Operation

```
AT+MDCH=<mode> <CR><LF><CR><LF>
```

```
+ok<CR><LF><CR><LF>
```
- Parameters:
 - ◆ mode: Wi-Fi Auto Switch Mode
 - ◇ off: Disable Wi-Fi auto switch. When response with auto, it is the same as off.
 - ◇ on: Enable Wi-Fi auto switch. When the module(STA mode) fail to connect to router, it will switch to AP mode itself in one minute.

4.2.2.44. AT+OTA

- Function: Set OTA Upgrade
- Format:
 - ◆ Set Operation

```
AT+OTA<CR>
```

```
+ok=<CR><LF><CR><LF>
```

Note: See Appendix C Module Upgrade for detail

4.2.2.45. AT+UPURL

- Function: Set/ Query remote upgrade URL address;
- Format:
 - ◆ Query Operation

```
AT+UPURL<CR>
```

```
+ok=<url><CR><LF><CR><LF>
```
 - ◆ Set Operation

```
AT+UPURL=<url,filename><CR>
```

```
+ok=<result><CR><LF><CR><LF>
```
- Parameters:
 - ◆ url: the upgrade file url address; the last charter shall be "/" (within 20 characters).
 - ◆ filename: the upgrade file name, it's optional and not saved parameter. If provide this file name here, the module will start upgrade right away;
 - ◆ result: the download operation result.
 - Download failed: Url is error or file is not valid.
 - Update success: Need reboot to run new the download new firmware.

4.2.2.46. AT+DISPS

- Function: Set/Query power save parameters;
- Format:
 - ◆ Query Operation
AT+DISPS<CR>
+ok=<ret><CR><LF><CR><LF>
 - ◆ Set Operation
AT+DISPS=<mode[,time]><CR><LF><CR><LF>
- Parameters:
 - ◆ ret:
 - ◇ No: Enable power save
 - ◇ Yes: Disable power save
 - ◇ Auto: Auto power save mode(default), enter power saving mode after receive or send data in time seconds.
 - ◆ mode:
 - ◇ No: Enable power save
 - ◇ Yes: Disable power save
 - ◇ Auto: Auto power save mode(default), enter power saving mode after receive or send data in time seconds.
 - ◆ time: Only valid in auto mode, >=2 integer value, default is 3 seconds. when value is 0, the default waiting time is still 3 seconds.

4.2.2.47. AT+PLANG

- Function: Set/Query webpage language option;
- Format:
 - ◆ Query Operation
AT+PLANG<CR>
+ok=<language><CR><LF><CR><LF>
 - ◆ Set Operation
AT+PLANG=<language> <CR>
+ok<CR><LF><CR><LF>
- Parameters:
 - ◆ language: webpage's language
 - ◇ CN: Chinese Version (Default);
 - ◇ EN: English Version;

4.2.2.48. AT+WEBU

- Function: Set/ Query webpage user name and password; Setting is valid after reset.
- Format:
 - ◆ Query Operation
AT+WEBU<CR>
+ok=<username,password> <CR><LF><CR><LF>
 - ◆ Set Operation
AT+WEBU=<username,password><CR>

+ok<CR><LF><CR><LF>

- Parameters:
 - ◆ username: User Name, within 15 characters, not support empty.
 - ◆ password: password, within 15 characters, support empty.

4.2.2.49. AT+WRMID

- Function: Set module ID;
- Format:
 - ◆ Set Operation

AT+WRMID=<wrmid> <CR><LF><CR><LF>

- Parameters:
 - ◆ wrmid: set module's ID (within 20 characters).

4.2.2.50. AT+ASWD

- Function: Set/Query WiFi Configuration Password;
- Format:
 - ◆ Query Operation

AT+ASWD<CR>

+ok=<aswd> <CR><LF><CR><LF>

- ◆ Set Operation

AT+ASWD=<aswd><CR><LF><CR><LF>

- Parameters:
 - ◆ aswd: WiFi Configuration Password (within 20 characters).

4.2.2.51. AT+SMTLK

- Function: Start SmartLink function
- Format:
 - ◆ Query Operation

AT+SMTLK<CR>

SmartLink is a One-Key config function. Config the module connecting to router easily. After start SmartLink function , the module work in SmartLink status and nLink LED is fast flashing waiting for APP to push information. See the Appendix for more details.

4.2.2.52. AT+NDBGL

- Function: Enable/Disable UART debug information
- Format:
 - ◆ Query Operation

AT+NDBGL<CR>

+ok=<debug_level,uart_num> <CR><LF><CR><LF>

- ◆ Set Operation

AT+NDBGL=<debug_level,uart_num><CR>

+ok<CR><LF><CR><LF>

- Parameters:
 - ◆ debug_level: UART debug level value
 - ✧ 0: Disable debug information output

- ◇ 1~XX: Output internal UART debug information which is same or higher than this set value
- ◆ uart_num: UART debug information output channel
 - ◇ 0: UART0
 - ◇ 1: UART1, 921600bps, with more system information output.

4.2.2.53. AT+TYPE

- Function: Set/Query WeChat device type.
- Format:
 - ◆ Query Operation
AT+TYPE<CR>
+ok=<type> <CR><LF><CR><LF>
 - ◆ Set Operation
AT+TYPE=<type><CR><LF><CR><LF>
- Parameters:
 - ◆ type: WeChat device type. Ex: gh_ba0c25259dca.

4.2.2.54. AT+SMEM

- Function: Query the RAM malloc status.
- Format:
 - ◆ Query Operation
AT+SMEM<CR>
+ok=<status><CR><LF><CR><LF>
- Parameters:
 - ◆ status: The RAM malloc status. Ex for 1MB:
current_size:47016, max_size:41696, total_size:89984, alloc_cnt:42968, alloc_fail_cnt:0

4.2.2.55. AT+WIFI(Reserved)

- Function: Enable/Disable Wi-Fi Command
- Format:
 - ◆ Query Operation
AT+WIFI<CR>
+ok=<status> <CR><LF><CR><LF>
 - ◆ Set Operation
AT+WIFI =<status><CR>
+ok<CR><LF><CR><LF>
- Parameters:
 - ◆ status: Wi-Fi status.
 - ◇ UP(boot default status): Enable Wi-Fi Chip
 - ◇ DOWN: Disable Wi-Fi Chip, it will take several seconds(max 10) to disable the Wi-Fi, if response with +ERR=-5 means disable failed, usually it is already in disable status.

Note: Some Wi-Fi status change command(AT+WMODE and so on)need to reboot before valid. But may use this command only to reboot the Wi-Fi Chip to make the corresponding

command valid. This is AT+WIFI=DOWN, AT+WSSSID to set router information and then AT+WIFI=UP.

4.2.2.56. AT+WFREQ

- Function: Set Wi-Fi frequency mode
- Format:
 - ◆ Query Operation

```
AT+WFREQ<CR>
```

```
+ok=<status> <CR><LF><CR><LF>
```
 - ◆ Set Operation

```
AT+WFREQ=<status><CR>
```

```
+ok<CR><LF><CR><LF>
```
- Parameters:
 - ◆ status: Wi-Fi frequency mode.
 - ◇ 2G: Works only in 802.11bgn 2.4G
 - ◇ 5G: Works only in 802.11a 5G
 - ◇ 2G5G: default value. Works both is 2.4G and 5G

4.2.2.57. AT+SMARTAPCONFIG

- Function: Config SmartAPLink function
- Format:
 - ◆ Query Operation

```
AT+SMARTAPCONFIG<CR>
```

```
+ok=<status,[ap_prefix,ap_key]><CR><LF><CR><LF>
```
 - ◆ Set Operation

```
AT+SMARTAPCONFIG=<status,[ap_prefix,ap_key]><CR>
```

```
+ok<CR><LF><CR><LF>
```
- Parameters:
 - ◆ status: Enable/Disable SmartAPLink function
 - ◇ on: Enable SmartAPLink function, after enabled, use AT+SMARTAPSTART or nReload to start config.
 - ◇ off: Disable SmartAPLink. Default.
 - ◆ ap_prefix: module AP SSID prefix, default is hiflying_softap
 - ◆ ap_key: module AP password, blank for no password, password length 8~20.
 - ◆ ..

4.2.2.58. AT+SMARTAPSTART

- Function: Start SmartAPLink function, only valid if SmartAPLink is enabled.
- Format:
 - ◆ Query Operation

```
AT+SMARTAPSTART<CR>
```

```
+ok<CR><LF><CR><LF>
```

Note: Reset to quit this config mode.

5. PACKAGE INFORMATION

5.1. Recommended Reflow Profile

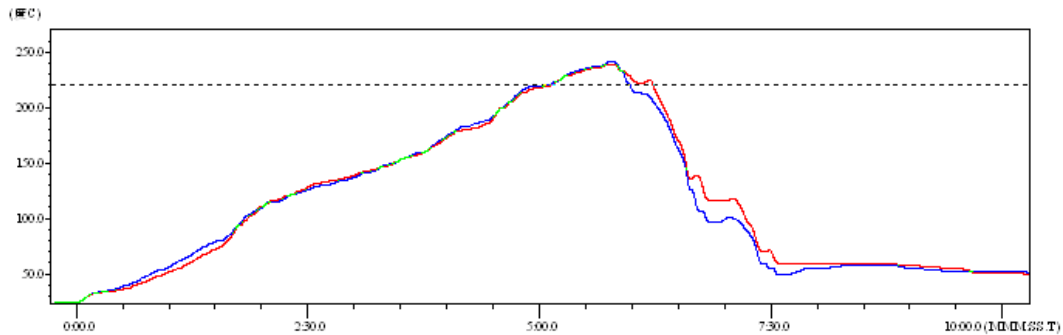

Figure 46. Reflow Soldering Profile

Table11. Reflow Soldering Parameter

NO.	Item	Temperature (Degree)	Time(Sec)
1	Reflow Time	Time of above 220	35~55 sec
2	Peak-Temp	260 max	

- Note:** 1. Recommend to supply N2 for reflow oven.
 2. N2 atmosphere during reflow (O2<300ppm)

5.2. Device Handling Instruction (Module IC SMT Preparation)

- Shelf life in sealed bag: 12 months, at <30°C and <60% relative humidity (RH).
- After bag is opened, devices that will be re-baked required after last baked with window time 168 hours.
- Recommend to oven bake with N2 supplied
- Recommend end to reflow oven with N2 supplied
- Baked required with 24 hours at 125+/-5°C before rework process.
- Recommend to store at ≤10% RH with vacuum packing
- If SMT process needs twice reflow:
 - Top side SMT and reflow
 - Bottom side SMT and reflow

Case 1: Wifi module mounted on top side. Need to bake when bottom side process over 168 hours window time, no need to bake within 168 hours

Case 2: Wifi module mounted on bottom side, follow normal bake rule before process

Note: Window time means from last bake end to next reflow start that has 168 hours space.

5.3. HF-LPD100 Shipping Information



Figure 47. HF-LPD100/HF-LPT230 Shipping Information

Note:

1 tape = 900pcs

1 box = 5 tapes = 5 * 900 pcs = 4500pcs

APPENDIX A: HW REFERENCE DESIGN

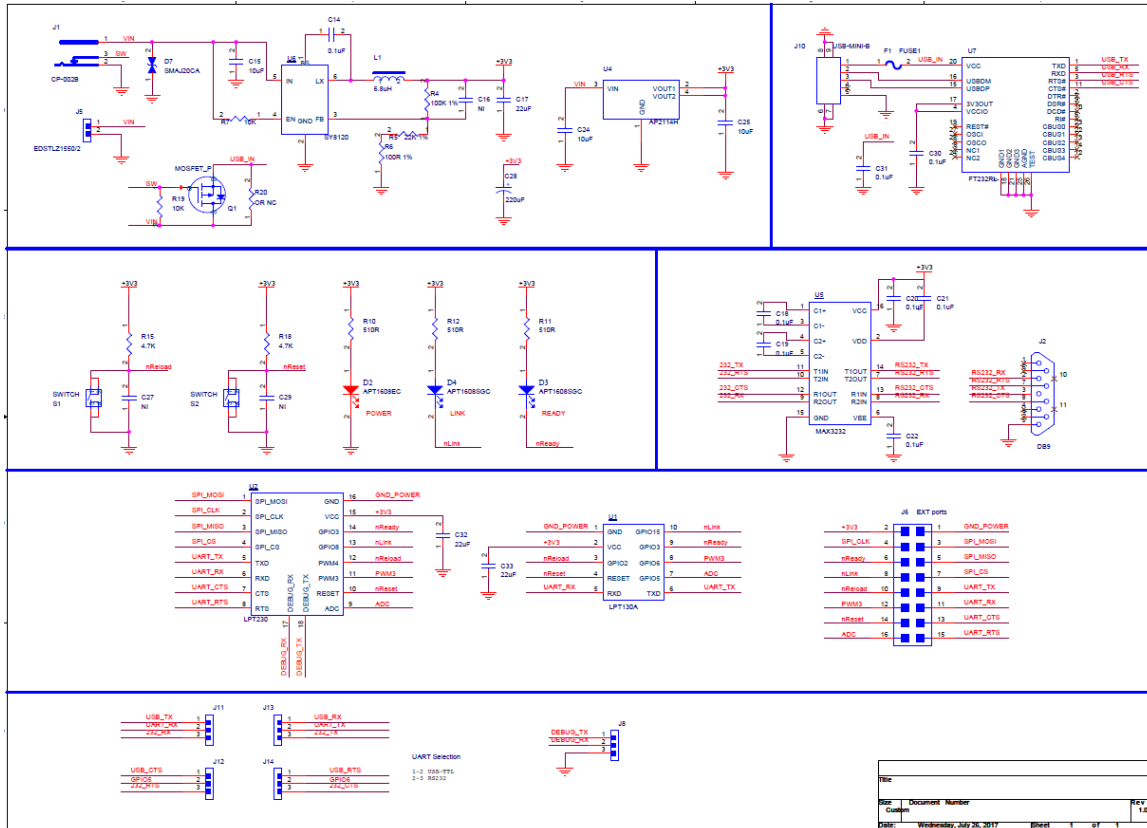

Detailed HF-LPD100 Evaluation Board design source files, pls access High-Flying web download page or contact with High-Flying technical support people to acquire.

APPENDIX B: HTTP PROTOCOL TRANSFER

HF-LPD100 module support http data transfer in throughput mode. If any detailed HTTP protocol, contact us and we may support customization.

B.1. Sending HTTP Raw Data in Throughput Mode

Step 1、Configure HTTP server information

```
AT+NETP=tcp,client,80,testnewjava.gotoip4.com
+ok
```

Step 2、Configure module connecting to router AP and reboot.

```
AT+WSSSID=Tenda_GYH
+ok

AT+WSKEY=wpa2psk,aes,12345678
+ok

AT+WMODE=sta
+ok

AT+Z
```

Step 3、Sending HTTP raw data via UART, end the data with<CR><LF><CR><LF>

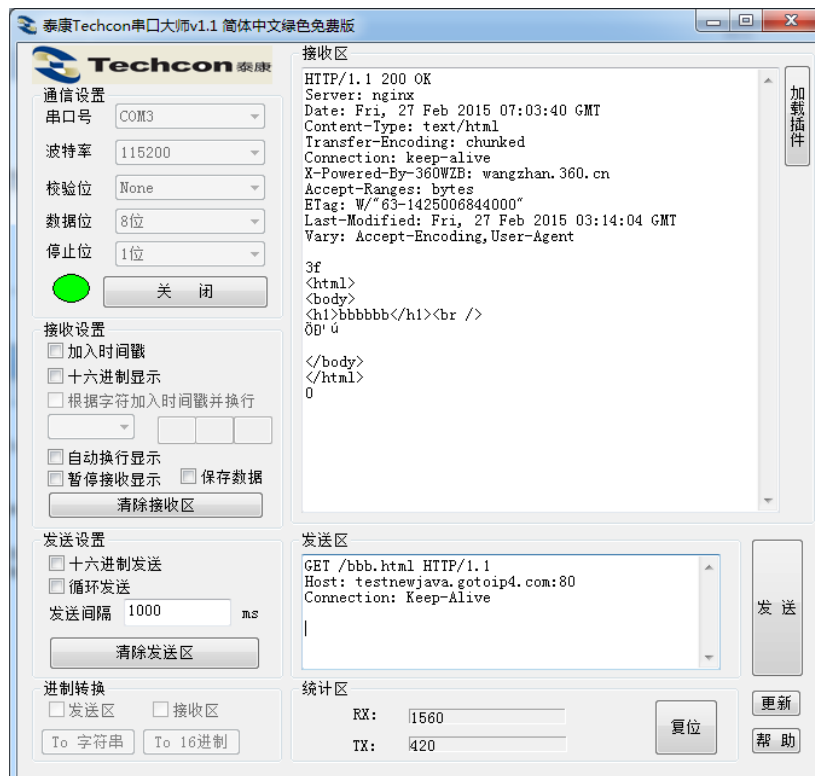

APPENDIX C:REFERENCES

C.1. High-Flying Mass Production Tool

Download Address: <http://www.hi-flying.com/download-center-1/applications-1/download-item-production-tool>

C.2. SmartLink APP V8 Sniffer Config Tool

Download Address : <http://www.hi-flying.com/download-center-1/applications-1/download-item-smartlink-v8>

C.3. SmartAPLink

Download Address: <http://www.hi-flying.com/download-center-1/applications-1/download-item-smartaplink>

C.4. Firmware

Download Address: http://www.hi-flying.com/index.php?route=download/category&path=1_3

C.5. SDK

Download Address: http://www.hi-flying.com/index.php?route=download/category&path=1_2

APPENDIX D: CONTACT INFORMATION

Address: [Room 1002,Building 1,No.3000,Longdong Avenue,Pudong New Area,Shanghai,China,201203](#)

Web: www.hi-flying.com

Service Online: [400-189-3108/18616078755](tel:400-189-3108/18616078755)

Sales Contact: sales@hi-flying.com

For more information about High-Flying modules, applications, and solutions, please visit our web site <http://www.hi-flying.com/en/>

<END OF DOCUMENT>

© Copyright High-Flying, May, 2011

The information disclosed herein is proprietary to High-Flying and is not to be used by or disclosed to unauthorized persons without the written consent of High-Flying. The recipient of this document shall respect the security status of the information.

The master of this document is stored on an electronic database and is "write-protected" and may be altered only by authorized persons at High-Flying. Viewing of the master document electronically on electronic database ensures access to the current issue. Any other copies must be regarded as uncontrolled copies.