

GENERAL TOLERANCE

DIM. RANGE	0-3	>3-6	>6-30	>30-120	>120-400
TOLERANCE	±0.1	±0.1	±0.2	±0.3	±0.5

CUSTOMER DRAWING



REV.	DESCRIPTION	DATE
D	ADD NOTE FOR MASTER KEYWAY	2016-06-01
E	UPDATE CURRENT & TEMP. RATING	2016-11-12
F	UPDATE SPECIFICATION TABLE ADD DIA. A & DIM "15" ADD 25SQMM OPTION UPDATE 2&4 CORRECT OPERATING TEMPERATURE	2019-01-16

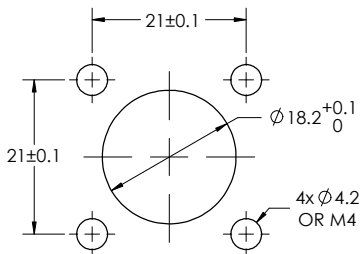
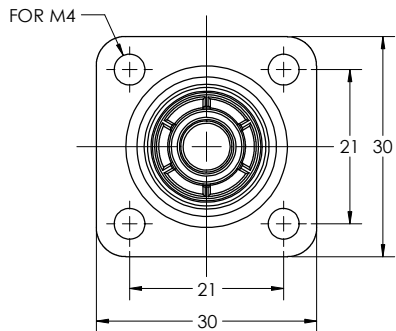

RECOMMENDED PANEL LAYOUT

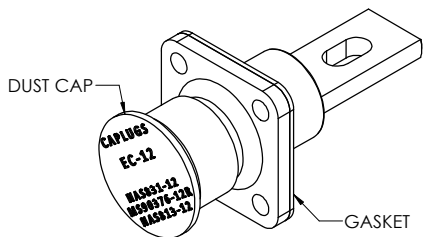

DUST CAP ASSEMBLY DIAGRAM

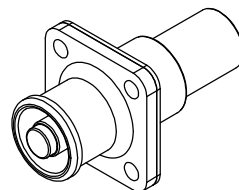
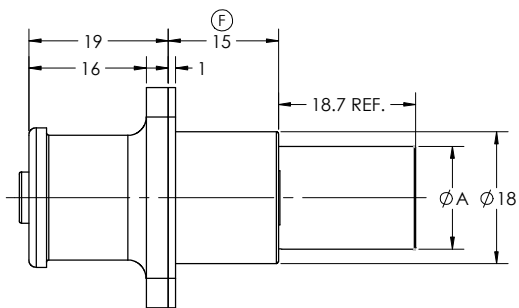

CRIMP TYPE

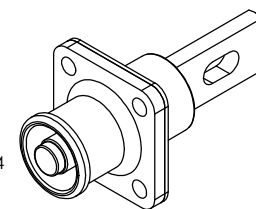
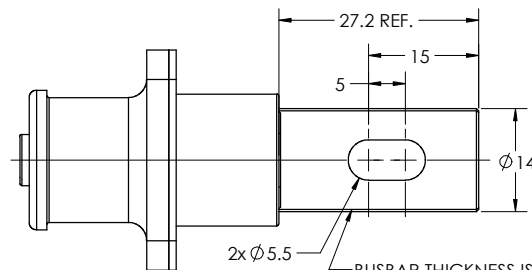

BUSBAR TYPE

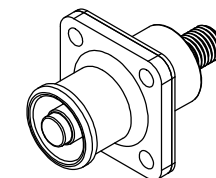
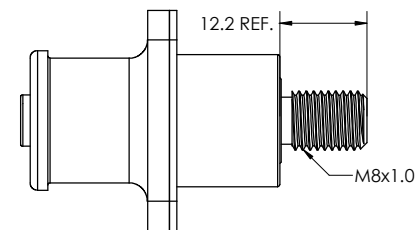

SCREW TYPE

MFG NUMBER: C10-730189-() () ()

COLOR
PIN TYPE
SEALING

CODE NUMBER: SLPRB () P () ()

PIN TYPE
PANEL MOUNT
SEALING
COLOR

ITEM	OPTION	CODE NUMBER	MFG NUMBER
COLOR	ORANGE	O	0
	BLACK	B	1
	RED	R	2
PIN TYPE	25 SQMM CRIMPING	25C	4
	35 SQMM CRIMPING	35C	3
	50 SQMM CRIMPING	50C	0
	BUSBAR	B	1
	SCREW	T	2
SEALING	IP67(MATED)	S	0
	NO SEALING	N	1

SPECIFICATION	
CURRENT RATING	120A MAX FOR 25 SQMM 150A MAX FOR 35 SQMM 200A MAX FOR 50 SQMM
OPERATING VOLTAGE	1000V DC MAX.
OPERATING TEMPERATURE (AMBIENT)	-40 ~ +105 °C
CONTACT RESISTANCE	0.5mΩ MAX.
DURABILITY	100 CYCLES MIN
PROTECTION CLASS	IP67(MATED)

ⓕ	
DIAMETER "A"	WIRE SIZE
14	50 SQMM
12.5	35 SQMM
10	25 SQMM

4. RECOMMENDED PART NUMBER FOR SCREW TYPE: C10-763708-() ⓕ
3. IF CHOOSE NO SEALING OPTION, THERE WILL BE NO GASKET
2. DUST CAP SHOULD BE REMOVED BEFORE THE PLUG MATING IN. ⓕ
1. THE REFERENCED PRODUCT SHOULD BE COMPLIANT TO RoHS DIRECTIVE.

NOTES:

THIS DOCUMENT CONTAINS PROPRIETARY INFORMATION AND SUCH INFORMATION MAY NOT BE DISCLOSED TO OTHERS FOR ANY PURPOSE OR USED FOR MANUFACTURING PURPOSES WITHOUT WRITTEN PERMISSION FROM THE AMPHENOL CORP.

UNLESS OTHERWISE SPECIFIED		APPROVALS	DATE
LINEAR DIMENSIONS ARE IN: MILLIMETERS TOLERANCES: ANGLES: ±2° DEFAULT LINEAR TOLERANCES SEE TABLE DIM. & TOL. PER ASME Y14.5M-1994; DRW PER MIL-DTL-31000; OTHER AMPHENOL STANDARDS: 9-3800		PREPARED BY: Thor Yan ENGINEER IN CHARGE: Seven Xie DESIGN MANAGER: Rob Weng PRODUCT GROUP: C&I AIPG DIVISION:	2016-03-18
LEGENDS: =FLAG NOTE CALL OUT REFERENCE		MATERIAL SPEC	PROCESS SPEC
THIRD ANGLE PROJECTION		N/A	N/A

AMPHENOL INDUSTRIAL OPERATIONS
Amphenol Technology (Zhuhai) Co., Ltd
No.63, Xinghan Road, Sanzao Town, Jinwan, Zhuhai, PRC

8.0MM SURLOK PLUS RECEPTACLE
WITHOUT KEYWAY TYPE

SIZE	CAGE CODE	DOCUMENT NUMBER	REV
C	77820	10-730189-()	F
SCALE: 1.5:1	REF:	N/A	SHEET 1 OF 1