

3-Terminal 1A Positive Voltage Regulator

Description

The 78MXX series of three-terminal positive regulators are available in the TO-220C/TO-252 package with several fixed output voltages making it useful in a wide range of applications.

Features

- ◆ Output Current up to 1A
- ◆ Output Voltages of 5,6,8,10,12,15,18,20,24V
- ◆ Thermal Overload Protection
- ◆ Short Circuit Protection
- ◆ Output Transistor Safe Operating area (SOA) Protection

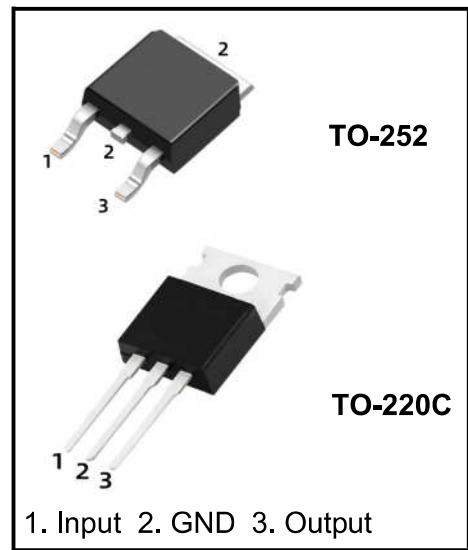

Internal Block Diagram

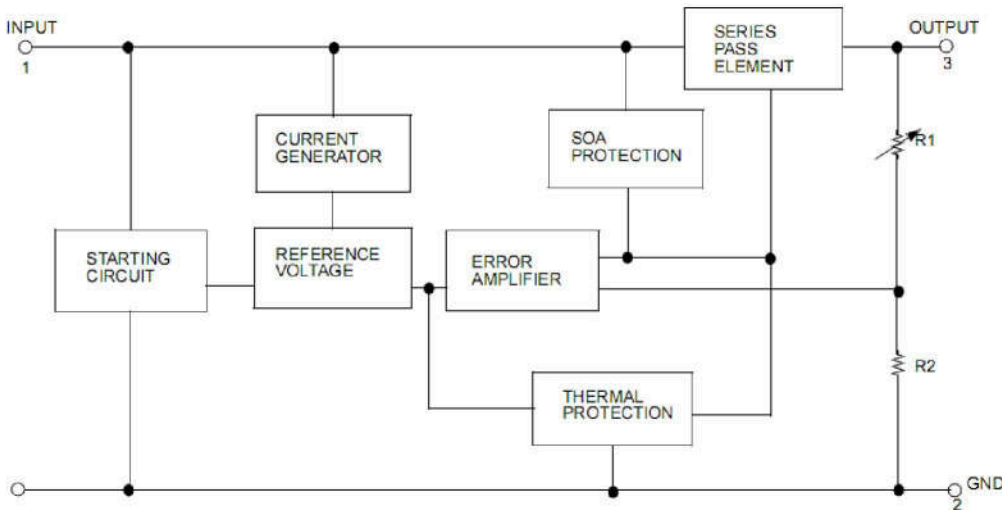

Absolute Maximum Ratings

Parameter		Symbol	Value	Unit
Input Voltage	$V_O = 5V \sim 18V$	V_{IN}	35	V
	$V_O = 24V$		40	
Thermal Resistance Junction-Cases (TO-220C)		$R_{\theta JC}$	5	$^{\circ}C/W$
Thermal Resistance Junction-Air	TO-220C	$R_{\theta JA}$	65	$^{\circ}C/W$
	TO-252		92	
Operating Temperature Range		T_{OPR}	$0 \sim +125$	$^{\circ}C$
Storage Temperature Range		T_{STG}	$-55 \sim +150$	$^{\circ}C$

Note 1 Absolute maximum ratings are those values beyond which damage to the device may occur. The datasheet specifications should be met, without exception, to ensure that the system design is reliable over its power supply, temperature, and output/input loading variables. Fairchild does not recommend operation outside datasheet specifications.

Electrical Characteristics (78M05)

(V_I = 10V, I_O = 0.5A, C_I = 0.33μF, C_O = 0.1μF, T_J = -40°C to 125°C, unless otherwise specified)

Parameter	Symbol	Conditions	Min	Typ	Max	Unit
Output Voltage	V _O	T _J = 25°C, I _O = 5mA ~ 1A	4.80	5.0	5.20	V
		V _I = 7V ~ 20V, I _O = 5mA ~ 1A	4.75	5.0	5.25	V
Line Regulation ②	ΔV _O	T _J = 25°C	V _I = 7V ~ 25V		100	mV
			V _I = 8V ~ 12V		50	
Load Regulation ②	ΔV _O	T _J = 25°C	I _O = 5mA ~ 1A		100	mV
			I _O = 0.25A ~ 0.75A		50	
Quiescent Current	I _Q	T _J = 25°C			8.0	mA
Quiescent Current Change	ΔI _Q	I _O = 5mA ~ 1A			0.5	mA
		V _I = 7V ~ 25V			1.3	
Output Voltage Drift ③	ΔV / ΔT	I _O = 5mA		-0.8		mV/°C
Output Noise Voltage	V _N	10Hz ≤ f ≤ 100KHz		42		μV/V _O
Ripple Rejection ③	RR	f = 120Hz, V _I = 8V ~ 18V	62	73		dB
Output Resistance ③	R _O	f = 1kHz		15		mΩ
Short Circuit Current	I _{SC}	T _J = 25°C, V _I = 30V		230		mA
Peak Out Current ③	I _{PK}	T _J = 25°C		1.8		A
Dropout Voltage	V _d	T _J = 25°C, I _O = 1A		2.0		V

Note 2: Load and line regulation are specified at constant junction temperature. Changes in V_O due to heating effects must be taken into account separately. Pulse testing with low duty is used.

Note 3: These parameters, although guaranteed, are not 100% tested in production.

Electrical Characteristics (78M06)

($V_I = 11V$, $I_o = 0.5A$, $C_I = 0.33\mu F$, $C_O = 0.1\mu F$, $T_j = -40$ to $125^\circ C$, unless otherwise specified)

Parameter	Symbol	Conditions	Min	Typ	Max	Unit
Output Voltage	V_O	$T_j = 25^\circ C$, $I_o = 5mA \sim 1A$	5.76	6.0	6.24	V
		$V_I = 8V \sim 12V$, $I_o = 5mA \sim 1A$	5.70	6.0	6.30	V
Line Regulation ④	ΔV_O	$T_j = 25^\circ C$	$V_I = 8V \sim 25V$		120	mV
			$V_I = 9V \sim 13V$		60	
Load Regulation ④	ΔV_O	$T_j = 25^\circ C$,	$I_o = 5mA \sim 1A$		120	mV
			$I_o = 0.25A \sim 0.75A$		60	
Quiescent Current	I_Q	$T_j = 25^\circ C$			8.0	mA
Quiescent Current Change	ΔI_Q	$I_o = 5mA \sim 1A$			0.5	mA
		$V_I = 8V \sim 25V$			1.3	
Output Voltage Drift ⑤	$\Delta V / \Delta T$	$I_o = 5mA$		-0.8		mV/°C
Output Noise Voltage	V_N	$10Hz \leq f \leq 100KHz$		76		$\mu V/V_O$
Ripple Rejection ⑤	RR	$f = 120Hz, V_I = 8V \sim 18V$	55	71		dB
Output Resistance ⑤	R_O	$f = 1kHz$		19		m Ω
Short Circuit Current	I_{SC}	$T_j = 25^\circ C$, $V_I = 30V$		230		mA
Peak Out Current ⑤	I_{PK}	$T_j = 25^\circ C$		1.8		A
Dropout Voltage	V_d	$T_j = 25^\circ C$, $I_o = 1A$		2.0		V

Note 4: Load and line regulation are specified at constant junction temperature. Changes in V_O due to heating effects must be taken into account separately. Pulse testing with low duty is used.

Note 5: These parameters, although guaranteed, are not 100% tested in production.

Electrical Characteristics (78M08)

(V_I = 14V, I_O = 0.5A, C_I = 0.33μF, C_O = 0.1μF, T_J = -40 to 125°C, unless otherwise specified)

Parameter	Symbol	Conditions	Min	Typ	Max	Unit
Output Voltage	V _O	T _J = 25°C, I _O = 5mA ~ 1A	7.68	8.0	8.32	V
		V _I = 10.5V ~ 23V, I _O = 5mA ~ 1A	7.60	8.0	8.40	V
Line Regulation ⑥	ΔV _O	T _J = 25°C	V _I = 10.5V ~ 25V		160	mV
			V _I = 11.5V ~ 17V		80	
Load Regulation ⑥	ΔV _O	T _J = 25°C,	I _O = 5mA ~ 1A		160	mV
			I _O = 0.25A ~ 0.75A		80	
Quiescent Current	I _Q	T _J = 25°C			8.0	mA
Quiescent Current Change	ΔI _Q	I _O = 5mA ~ 1A			0.5	mA
		V _I = 10.5V ~ 25V			1.0	
Output Voltage Drift ⑦	ΔV / ΔT	I _O = 5mA		-0.8		mV/°C
Output Noise Voltage	V _N	10Hz ≤ f ≤ 100KHz		52		μV/V _O
Ripple Rejection ⑦	RR	f = 120Hz, V _I = 11.5V ~ 21.5V	56	73		dB
Output Resistance ⑦	R _O	f = 1kHz		17		mΩ
Short Circuit Current	I _{SC}	T _J = 25°C, V _I = 30V		230		mA
Peak Out Current ⑦	I _{PK}	T _J = 25°C		1.8		A
Dropout Voltage	V _d	T _J = 25°C, I _O = 1A		2.0		V

Note 6: Load and line regulation are specified at constant junction temperature. Changes in V_O due to heating effects must be taken into account separately. Pulse testing with low duty is used.

Note 7: These parameters, although guaranteed, are not 100% tested in production.

Electrical Characteristics (78M09)

($V_I = 15V$, $I_o = 0.5A$, $C_I = 0.33\mu F$, $C_O = 0.1\mu F$, $T_j = -40$ to $125^\circ C$, unless otherwise specified)

Parameter	Symbol	Conditions	Min	Typ	Max	Unit
Output Voltage	V_O	$T_j = 25^\circ C$, $I_o = 5mA \sim 1A$	8.64	9.0	9.36	V
		$V_I = 11.5V \sim 24V$, $I_o = 5mA \sim 1A$	8.55	9.0	9.45	V
Line Regulation ⑧	ΔV_O	$T_j = 25^\circ C$	$V_I = 11.5V \sim 25V$		180	mV
			$V_I = 12V \sim 17V$		90	
Load Regulation ⑧	ΔV_O	$T_j = 25^\circ C$	$I_o = 5mA \sim 1A$		180	mV
			$I_o = 0.25A \sim 0.75A$		90	
Quiescent Current	I_Q	$T_j = 25^\circ C$			8.0	mA
Quiescent Current Change	ΔI_Q	$I_o = 5mA \sim 1A$			0.5	mA
		$V_I = 11.5V \sim 26V$			1.3	
Output Voltage Drift ⑨	$\Delta V / \Delta T$	$I_o = 5mA$		-1.0		mV/ $^\circ C$
Output Noise Voltage	V_N	$10Hz \leq f \leq 100KHz$		52		$\mu V/V_O$
Ripple Rejection ⑨	RR	$f = 120Hz$, $V_I = 13V \sim 23V$	56	71		dB
Short Circuit Current	I_{SC}	$T_j = 25^\circ C$, $V_I = 30V$		230		mA
Output Resistance ⑨	R_O	$f = 1kHz$		17		m Ω
Peak Out Current ⑨	I_{PK}	$T_j = 25^\circ C$		1.8		A
Dropout Voltage	V_d	$T_j = 25^\circ C$, $I_o = 1A$		2.0		V

Note 8: Load and line regulation are specified at constant junction temperature. Changes in V_O due to heating effects must be taken into account separately. Pulse testing with low duty is used.

Note 9: These parameters, although guaranteed, are not 100% tested in production.

Electrical Characteristics (78M10)

(V_I = 16V, I_O = 0.5A, C_I = 0.33μF, C_O = 0.1μF, T_J = -40 to 125°C, unless otherwise specified)

Parameter	Symbol	Conditions	Min	Typ	Max	Unit
Output Voltage	V _O	T _J = 25°C, I _O = 5mA ~ 1A	9.60	10.0	10.40	V
		V _I = 12.5V ~ 25V, I _O = 5mA ~ 1A	9.50	10.0	10.50	V
Line Regulation ⑩	ΔV _O	T _J = 25°C	V _I = 12.5V ~ 25V		200	mV
			V _I = 13V ~ 25V		100	
Load Regulation ⑩	ΔV _O	T _J = 25°C,	I _O = 5mA ~ 1A		200	mV
			I _O = 0.25A ~ 0.75A		100	
Quiescent Current	I _Q	T _J = 25°C			8.0	mA
Quiescent Current Change	ΔI _Q	I _O = 5mA ~ 1A			0.5	mA
		V _I = 12.5V ~ 29V			1.0	
Output Voltage Drift ⑪	ΔV / ΔT	I _O = 5mA		-1.0		mV/°C
Output Noise Voltage	V _N	10Hz ≤ f ≤ 100KHz		58		μV/V _O
Ripple Rejection ⑫	RR	f = 120Hz, V _I = 13V ~ 23V	56	71		dB
Short Circuit Current	I _{SC}	T _J = 25°C, V _I = 30V		230		mA
Output Resistance ⑬	R _O	f = 1kHz		17		mΩ
Peak Out Current ⑭	I _{PK}	T _J = 25°C		1.8		A
Dropout Voltage	V _d	T _J = 25°C, I _O = 1A		2.0		V

Note 10: Load and line regulation are specified at constant junction temperature. Changes in V_O due to heating effects must be taken into account separately. Pulse testing with low duty is used.

Note 11: These parameters, although guaranteed, are not 100% tested in production.

Electrical Characteristics (78M12)

(V_I = 19V, I_o = 0.5A, C_I = 0.33μF, C_O = 0.1μF, T_j = -40 to 125°C, unless otherwise specified)

Parameter	Symbol	Conditions	Min	Typ	Max	Unit
Output Voltage	V _O	T _j = 25°C, I _o = 5mA ~ 1A	11.52	12.0	12.48	V
		V _I = 14.5V ~ 27V, I _o = 5mA ~ 1A	11.40	12.0	12.60	V
Line Regulation ⑫	ΔV _O	T _j = 25°C I _o = 0.5A	V _I = 14.5V ~ 30V		240	mV
			V _I = 11.5V ~ 24V		120	
Load Regulation ⑫	ΔV _O	T _j = 25°C,	I _o = 5mA ~ 1A		240	mV
			I _o = 0.25A ~ 0.75A		120	
Quiescent Current	I _q	T _j = 25°C			8.0	mA
Quiescent Current Change	ΔI _q	I _o = 5mA ~ 1A			0.5	mA
		V _I = 14.5V ~ 30V			1.0	
Output Voltage Drift ⑬	ΔV / ΔT	I _o = 5mA		-1.0		mV/°C
Output Noise Voltage	V _N	10Hz ≤ f ≤ 100KHz		76		μV/V _O
Ripple Rejection ⑬	RR	f = 120Hz, V _I = 15V ~ 25V	55	71		dB
Output Resistance ⑬	R _O	f = 1kHz		18		mΩ
Short Circuit Current	I _{SC}	T _j = 25°C, V _I = 30V		230		mA
Peak Out Current ⑬	I _{PK}	T _j = 25°C		1.8		A
Dropout Voltage	V _d	T _j = 25°C, I _o = 1A		2.0		V

Note 12: Load and line regulation are specified at constant junction temperature. Changes in V_O due to heating effects must be taken into account separately. Pulse testing with low duty is used.

Note 13: These parameters, although guaranteed, are not 100% tested in production.

Electrical Characteristics (78M15)

($V_I = 23V$, $I_O = 0.5A$, $C_I = 0.33\mu F$, $C_O = 0.1\mu F$, $T_j = -40$ to $125^\circ C$, unless otherwise specified)

Parameter	Symbol	Conditions	Min	Typ	Max	Unit
Output Voltage	V_O	$T_j = 25^\circ C$, $I_O = 5mA \sim 1A$	14.40	15.0	15.60	V
		$V_I = 17.5V \sim 30V$, $I_O = 5mA \sim 1A$	14.25	15.0	15.75	V
Line Regulation ^⑭	ΔV_O	$T_j = 25^\circ C$ $I_O = 0.5A$	$V_I = 17.5V \sim 30V$		300	mV
			$V_I = 20V \sim 26V$		150	
Load Regulation ^⑭	ΔV_O	$T_j = 25^\circ C$,	$I_O = 5mA \sim 1A$		300	mV
			$I_O = 0.25A \sim 0.75A$		150	
Quiescent Current	I_Q	$T_j = 25^\circ C$			8.0	mA
Quiescent Current Change	ΔI_Q	$I_O = 5mA \sim 1A$			0.5	mA
		$V_I = 17.5V \sim 30V$			1.0	
Output Voltage Drift ^⑮	$\Delta V / \Delta T$	$I_O = 5mA$		-1.0		mV/ $^\circ C$
Output Noise Voltage	V_N	$10Hz \leq f \leq 100KHz$		90		$\mu V/V_O$
Ripple Rejection ^⑮	RR	$f = 120Hz$, $V_I = 18.5V \sim 28.5V$	54	70		dB
Output Resistance ^⑮	R_O	$f = 1kHz$		19		m Ω
Short Circuit Current	I_{SC}	$T_j = 25^\circ C$, $V_I = 30V$		230		mA
Peak Out Current ^⑮	I_{PK}	$T_j = 25^\circ C$		1.8		A
Dropout Voltage	V_d	$T_j = 25^\circ C$, $I_O = 1A$		2.0		V

Note 14: Load and line regulation are specified at constant junction temperature. Changes in V_O due to heating effects must be taken into account separately. Pulse testing with low duty is used.

Note 15: These parameters, although guaranteed, are not 100% tested in production.

Electrical Characteristics (78M18)

($V_I = 27V$, $I_O = 0.5A$, $C_I = 0.33\mu F$, $C_O = 0.1\mu F$, $T_J = -40$ to $125^\circ C$, unless otherwise specified)

Parameter	Symbol	Conditions	Min	Typ	Max	Unit
Output Voltage	V_O	$T_J = 25^\circ C$, $I_O = 5mA \sim 1A$	17.28	18.0	18.72	V
		$V_I = 21V \sim 30V$, $I_O = 5mA \sim 1A$	17.10	18.0	18.90	V
Line Regulation ⑩	ΔV_O	$T_J = 25^\circ C$ $I_O = 0.5A$	$V_I = 21V \sim 30V$		360	mV
			$V_I = 24V \sim 26V$		180	
Load Regulation ⑩	ΔV_O	$T_J = 25^\circ C$,	$I_O = 5mA \sim 1A$		300	mV
			$I_O = 0.25A \sim 0.75A$		150	
Quiescent Current	I_Q	$T_J = 25^\circ C$			8.0	mA
Quiescent Current Change	ΔI_Q	$I_O = 5mA \sim 1A$			0.5	mA
		$V_I = 21V \sim 30V$			1.0	
Output Voltage Drift ⑪	$\Delta V / \Delta T$	$I_O = 5mA$		-1.0		mV/ $^\circ C$
Output Noise Voltage	V_N	$10Hz \leq f \leq 100KHz$		110		$\mu V/V_O$
Ripple Rejection ⑫	RR	$f = 120Hz$, $V_I = 22V \sim 30V$	53	69		dB
Output Resistance ⑬	R_O	$f = 1kHz$		22		m Ω
Short Circuit Current	I_{SC}	$T_J = 25^\circ C$, $V_I = 30V$		230		mA
Peak Out Current ⑭	I_{PK}	$T_J = 25^\circ C$		1.8		A
Dropout Voltage	V_d	$T_J = 25^\circ C$, $I_O = 1A$		2.0		V

Note 16: Load and line regulation are specified at constant junction temperature. Changes in V_O due to heating effects must be taken into account separately. Pulse testing with low duty is used.

Note 17: These parameters, although guaranteed, are not 100% tested in production.

Electrical Characteristics (78M24)

($V_I = 33V$, $I_o = 0.5A$, $C_I = 0.33\mu F$, $C_O = 0.1\mu F$, $T_j = -40$ to $125^\circ C$, unless otherwise specified)

Parameter	Symbol	Conditions	Min	Typ	Max	Unit
Output Voltage	V_O	$T_j = 25^\circ C$, $I_o = 5mA \sim 1A$	23.04	24.0	24.96	V
		$V_I = 27V \sim 38V$, $I_o = 5mA \sim 1A$	22.80	24.0	25.20	V
Line Regulation ^⑱	ΔV_O	$T_j = 25^\circ C$ $I_o = 0.5A$	$V_I = 27V \sim 38V$		480	mV
			$V_I = 30V \sim 36V$		240	
Load Regulation ^⑱	ΔV_O	$T_j = 25^\circ C$,	$I_o = 5mA \sim 1A$		480	mV
			$I_o = 0.25A \sim 0.75A$		240	
Quiescent Current	I_Q	$T_j = 25^\circ C$			8.0	mA
Quiescent Current Change	ΔI_Q	$I_o = 5mA \sim 1A$			0.5	mA
		$V_I = 27V \sim 38V$			1.0	
Output Voltage Drift ^⑲	$\Delta V / \Delta T$	$I_o = 5mA$		-1.5		mV/ $^\circ C$
Output Noise Voltage	V_N	$10Hz \leq f \leq 100KHz$		60		$\mu V/V_O$
Ripple Rejection ^⑲	RR	$f = 120Hz$, $V_I = 28V \sim 38V$	50	67		dB
Output Resistance ^⑲	R_O	$f = 1kHz$		28		m Ω
Short Circuit Current	I_{SC}	$T_j = 25^\circ C$, $V_I = 35V$		230		mA
Peak Out Current ^⑲	I_{PK}	$T_j = 25^\circ C$		1.8		A
Dropout Voltage	V_d	$T_j = 25^\circ C$, $I_o = 1A$		2.0		V

Note 18: Load and line regulation are specified at constant junction temperature. Changes in V_O due to heating effects must be taken into account separately. Pulse testing with low duty is used.

Note 19: These parameters, although guaranteed, are not 100% tested in production.

Typical Characteristics

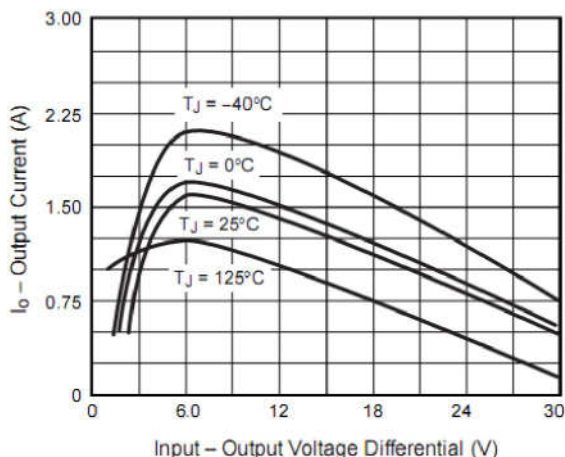

Figure 1. Peak Output Current

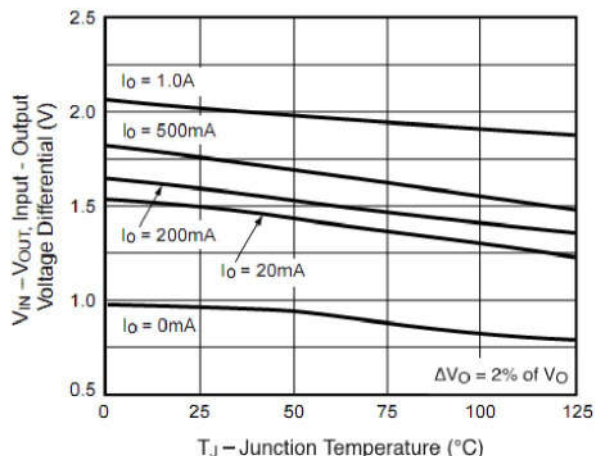

Figure 2. Dropout Voltage vs. Junction Temperature

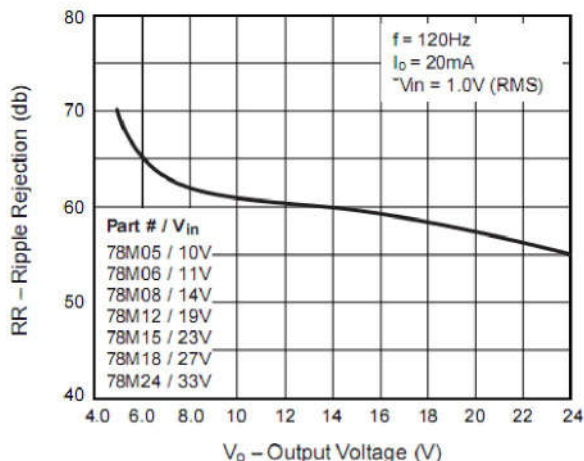

Figure 3. Ripple Rejection Ratio vs. Output Voltage

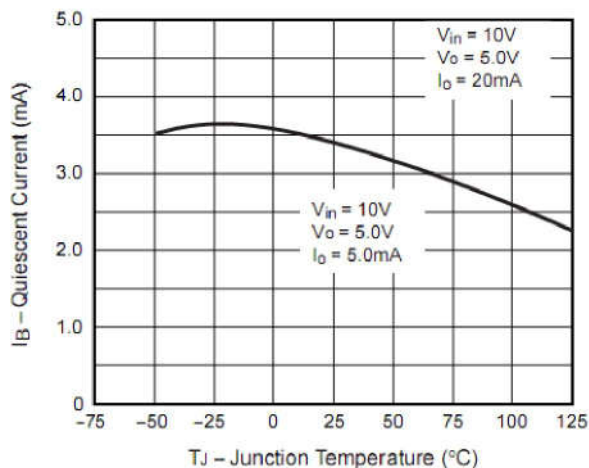

Figure 4. Quiescent Current vs. Junction Temperature

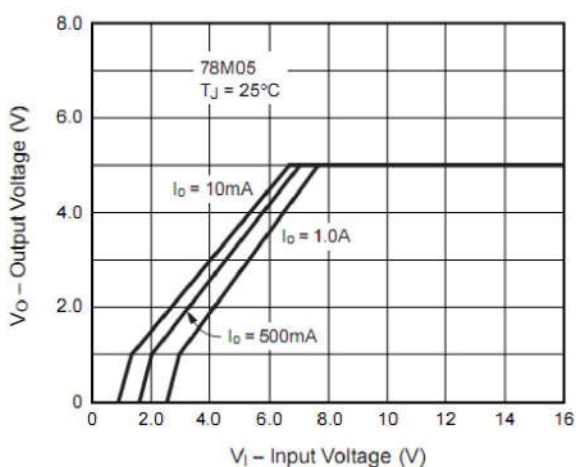

Figure 8. Output Voltage vs. Input Voltage

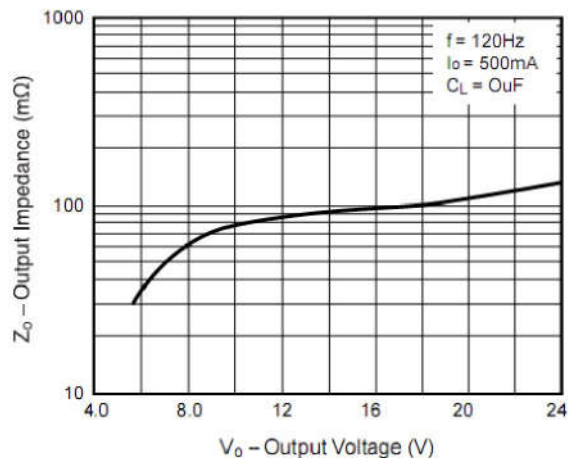
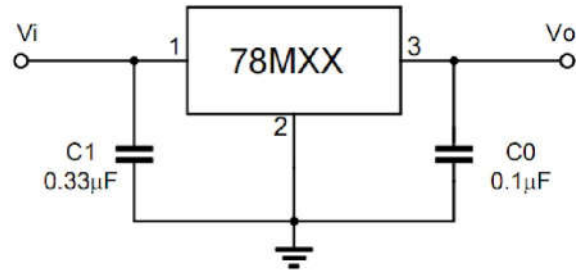

Figure 9. Output Impedance (mΩ) vs. Output Voltage

Application circuit



Note 1: To specify an output voltage, substitute voltage value for "MXX".

Note 2: Bypass capacitors are recommended for optimum stability and transient response and should be located as close as possible to the regulators.

Marking Diagram

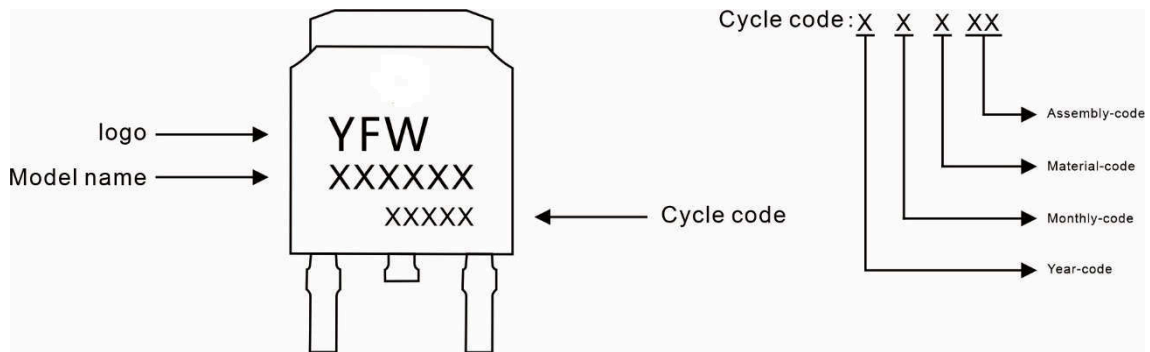

Ordering information

Model name	Package	Unit Weight	Base Quantity	Packing Quantity
78MXXAD	TO-252	0.011oz(0.32g)	2500pcs/reel	5000pcs/box 25000pcs/Carton

Package Dimensions

TO-252

Dim	Millimeter		Inches	
	Min.	Max.	Min.	Max.
A	2.20	2.50	0.087	0.098
A1	0.00	0.12	0.000	0.005
A2	2.20	2.40	0.087	0.094
B	1.20	1.60	0.047	0.063
b	0.50	0.70	0.020	0.028
b1	0.70	0.90	0.028	0.035
c	0.40	0.60	0.016	0.024
c1	0.40	0.60	0.016	0.024
D	6.35	6.65	0.250	0.262
D1	5.20	5.40	0.205	0.213
E	5.40	5.70	0.213	0.224
e	2.20	2.40	0.087	0.094
e1	4.40	4.80	0.173	0.189
L	10.00	11.00	0.393	0.433
L1	2.70	3.10	0.106	0.122
L2	1.40	1.80	0.055	0.071
L3	0.90	1.50	0.035	0.059

Marking Diagram

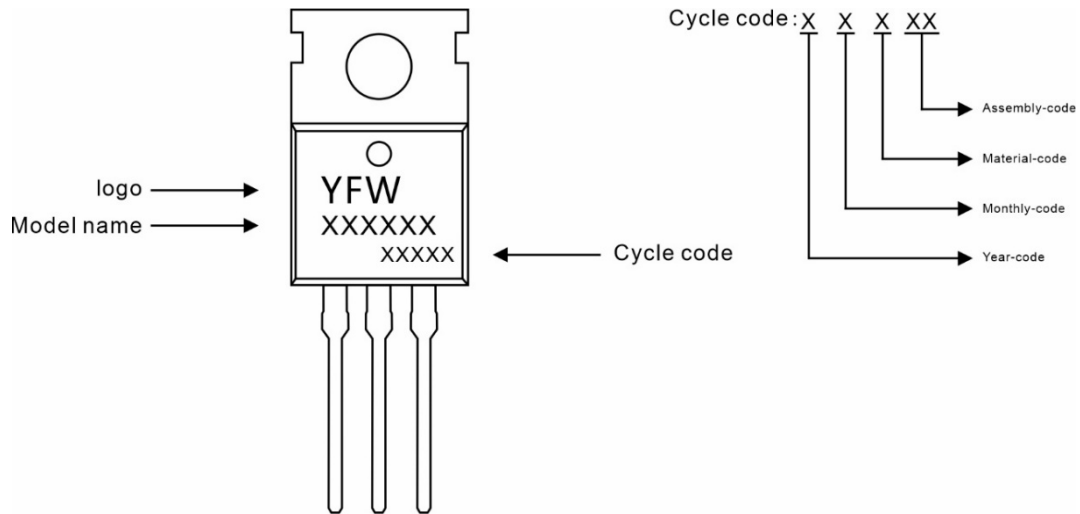

Ordering information

Model name	Package	Unit Weight	Base Quantity	Packing Quantity
78MXXAC	TO-220C	0.07oz(1.96g)	50pcs/tube	1000PCS/Box 5000PCS/Carton

Package Dimensions

TO-220C

Dim	Millimeter		Inches	
	Min.	Max.	Min.	Max.
A	4.34	4.67	0.171	0.184
A1	2.52	2.82	0.099	0.111
b	0.71	0.91	0.028	0.036
b1	1.17	1.37	0.046	0.054
c	0.30	0.50	0.012	0.020
c1	1.17	1.37	0.046	0.054
D	9.90	10.20	0.390	0.402
E	8.50	8.90	0.335	0.350
E1	12.00	12.50	0.472	0.492
e	2.44	2.64	0.096	0.104
e1	4.88	5.28	0.192	0.208
F	2.60	2.80	0.102	0.110
L	13.20	13.80	0.520	0.543
L1	3.80	4.20	0.150	0.165
Φ	3.60	3.96	0.142	0.156