

150kHz 3A Step-Down Voltage Regulator

1. Description

The LM2596 series of regulators are monolithic integrated circuit that provides all the active functions for a step-down (buck) switching regulator, capable of driving 3A load with excellent line and load regulation. The LM2596 available in fixed output voltages of 3.3V, 5V, 12V and an adjustable output version.

Requiring a minimum number of external components, these regulators are simple to use and include internal frequency compensation and a fixed-frequency oscillator.

The LM2596 series operates at a switching frequency of 150 kHz thus allowing smaller sized filter components than what would be needed with lower

frequency switching regulators. A standard of inductors optimized for use with the LM2596 are available from several different manufacturers. This feature greatly simplifies the design of switch-mode power supplies.

Other features include a guaranteed $\pm 4\%$ tolerance on output voltage within specified input voltages and output load conditions, and $\pm 15\%$ on the oscillator frequency. External shutdown is included, featuring 50 μ A (typical) standby current. The output switch includes cycle-by-cycle current limiting, as well as thermal shutdown for full protection under fault conditions.

2. Features

- 3.3V, 5V, 12V and Adjustable Output Versions
- High Efficiency
- Wide Input Voltage Range up to 40V
- Guaranteed 3A Output Current
- Requires only 4 External Components
- 150 kHz Fixed Frequency Internal Oscillator
- TTL Shutdown Capability, Low Power Standby Mode
- Uses Readily Available Standard Inductors
- Thermal Shutdown and Current Limit Protection
- Adjustable Version Output Voltage Range, 1.23V to 37V $\pm 4\%$ Max Over Line and Load Conditions

3. Applications

- Simple High-Efficiency Step-Down (Buck) Regulator
- Efficient Pre-Regulator for Linear Regulators
- On-Card Switching Regulators
- Positive to Negative Converter (Buck-Boost)

4. Pin Configuration

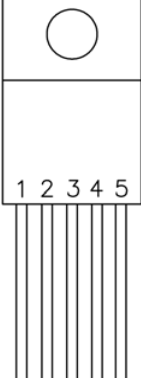
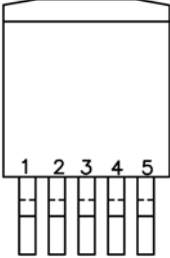
TO-220-5L	TO-263-5L
	

Pin NO.	Pin Name	Function Description
1	V _{IN}	This is the positive input supply for the IC switching regulator. A suitable input bypass capacitor must be present at this pin to minimize voltage transients and to supply the switching currents needed by the regulator.
2	OUTPUT	Internal switch, the voltage at this pin switches between (+V _{IN} V _{SAT}) and approximately -0.5V. To minimize coupling to sensitive circuitry, the PC board copper area connected to this pin should be kept to a minimum.
3	GND	Circuit Ground
4	FEEDBACK	Senses the regulated output voltage to complete the feedback loop
5	\overline{ON} / OFF	Allows the switching regulator circuit to be shut down using logic level signals.

5. Functional Block Diagram

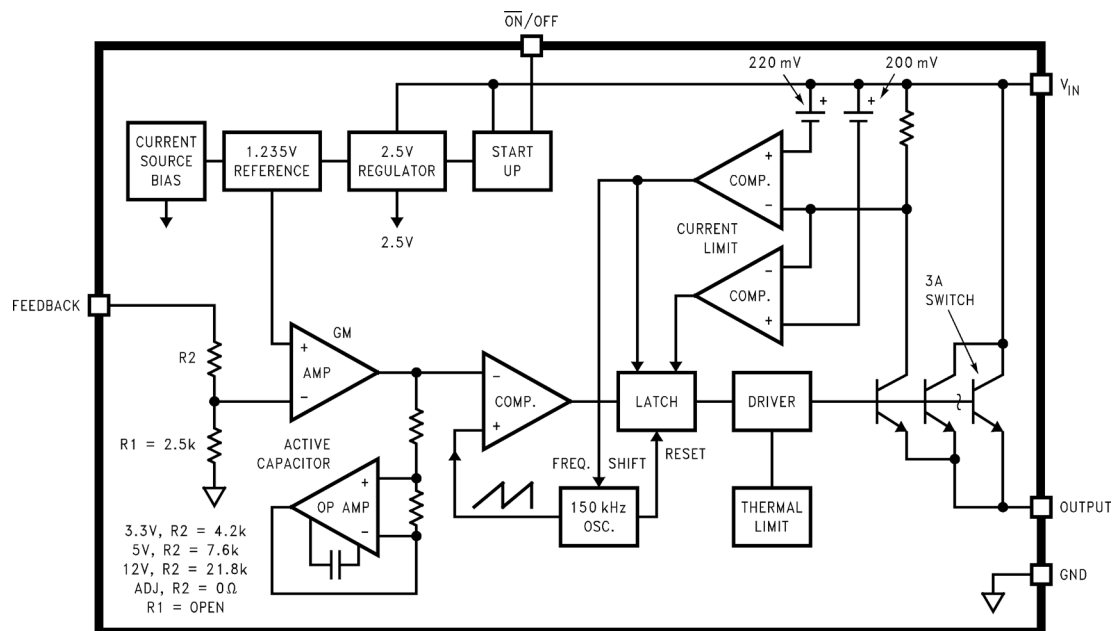

6. Ordering Information

Type Number	Package Type	Marking	Packing	Packing Qty
LM2596S-ADJ	TO-263-5L	LM2596-ADJ	Tape & Reel	500
LM2596S-3.3		LM2596-3.3	Tape & Reel	500
LM2596S-5.0		LM2596-5.0	Tape & Reel	500
LM2596S-12		LM2596-12	Tape & Reel	500
LM2596HVS-ADJ	TO-263-5L	LM2596-ADJ	Tape & Reel	500
LM2596HVS-3.3		LM2596-3.3	Tape & Reel	500
LM2596HVS-5.0		LM2596-5.0	Tape & Reel	500
LM2596HVS-12		LM2596-12	Tape & Reel	500
LM2596T-ADJ	TO-220-5L	LM2596-ADJ	Tube	1000
LM2596T-3.3		LM2596-3.3	Tube	1000
LM2596T-5.0		LM2596-5.0	Tube	1000
LM2596T-12		LM2596-12	Tube	1000
LM2596HVT-ADJ	TO-220-5L	LM2596-ADJ	Tube	1000
LM2596HVT-3.3		LM2596-3.3	Tube	1000
LM2596HVT-5.0		LM2596-5.0	Tube	1000
LM2596HVT-12		LM2596-12	Tube	1000

Note: If the physical information is inconsistent with the ordering information, please refer to the actual product.

7. Absolute Maximum Ratings

Parameter Name	Symbol	Value	Unit
Maximum Supply Voltage	V_{IN}	45	V
\overline{ON} / OFF Pin Input Voltage	\overline{ON} / OFF	$-0.3V \leq V \leq +V_{IN}$	V
Output Voltage to Ground (steady state)	V_{OUT}	-1	V
Power Dissipation	P_{DMAX}	Internally Limited	
Storage Temperature Range	T_{stg}	-65~+150	°C
Maximum Junction Temperature	T_{JA}	150	°C
ESD Susceptibility (Human Body Model)	ESD	2	kV
Lead Temperature (Soldering, 10 Seconds)	T_L	260	°C

8. Recommended Operating Conditions

Parameter Name	Symbol	Value	Unit
Supply Voltage	V_{IN}	6~40	V
Operating temperature range	T_{OPR}	-40~+125	°C

9. Electrical Characteristics

(Unless otherwise specified: $T_J = 25^\circ\text{C}$)

Parameter Name	Symbol	Test Conditions	Min	Typ	Max	Units
Device Parameters						
Feedback Bias Current	I_b	Adjustable version only, $V_{OUT}=5V$		50	100	nA
Oscillator Frequency	f_o		127	150	173	kHz
V_{SAT} Saturation Voltage	V_{SAT}	$I_{OUT}=3A$		1.4	1.8	V
Max. Duty Cycle(ON)	DC		93	98		%
Current Limit	I_{CL}	(Note 1)	3.6	4.5	6.9	A
Output Leakage Current	I_L	Output=0V			2	mA
		Output=-1V		7.5	30	mA
Quiescent Current	I_Q			5	10	mA
Standby Quiescent Current	I_{STBY}	\overline{ON} / OFF pin=5V(OFF)		50	200	μA
\overline{ON} / OFF Control						
\overline{ON} / OFF Pin Logic Input Level	V_{IH}	$V_{OUT}=0V$	2.0			V
	V_{IL}	$V_{OUT}=\text{nominal output voltage}$			0.8	V
\overline{ON} / OFF Pin Input Current	I_{IH}	\overline{ON} / OFF pin=5V(OFF)		12	30	μA
	I_{IL}	\overline{ON} / OFF pin=0V(ON)		0	10	μA

Note 1: The oscillator frequency reduces to approximately 11 kHz in the event of an output short or an overload which causes the regulated output voltage to drop approximately 40% from the nominal output voltage. This self-protection feature lowers the average power dissipation of the IC by lowering the minimum duty cycle from 5% down to approximately 2%. Output pin sourcing current. No diode, inductor or capacitor connected to output.

10. Electrical Characteristics (Continued)

Parameter Name	Symbol	Test Conditions	Min	Typ.	Max	Units
LM2596-3.3V						
Output Voltage	V_{OUT}	$V_{IN}=12V, I_O=500mA$	3.234	3.3	3.366	V
		$6V \leq V_{IN} \leq 40V$ $0.5A \leq I_{LOAD} \leq 3A$	3.168	3.3	3.450	V
Efficiency	η	$V_{IN}=12V, I_{LOAD}=3A$		73		%
LM2596-5.0V						
Output Voltage	V_{OUT}	$V_{IN}=12V, I_O=500mA$	4.90	5.00	5.10	V
		$8V \leq V_{IN} \leq 40V$ $0.5A \leq I_{LOAD} \leq 3A$	4.80	5.00	5.20	V
Efficiency	η	$V_{IN}=12V, I_{LOAD}=3A$		77		%
LM2596-12V						
Output Voltage	V_{OUT}	$V_{IN}=25V, I_O=500mA$	11.76	12.000	12.24	V
		$15V \leq V_{IN} \leq 40V$ $0.5A \leq I_{LOAD} \leq 3A$	11.52	12.00	12.48	V
Efficiency	η	$V_{IN}=25V, I_{LOAD}=3A$		88		%
LM2596-ADJ						
Output Voltage	V_{OUT}	$V_{IN}=12V, I_O=500mA, V_{OUT}=5V$	1.217	1.230	1.243	V
		$8V \leq V_{IN} \leq 40V, V_{OUT}=5V$ $0.5A \leq I_{LOAD} \leq 3A$	1.193	1.230	1.267	V
Efficiency	η	$V_{IN}=12V, I_{LOAD}=3A, V_{OUT}=5V$		77		%

11. Test Circuit

Fixed Output Voltage Versions

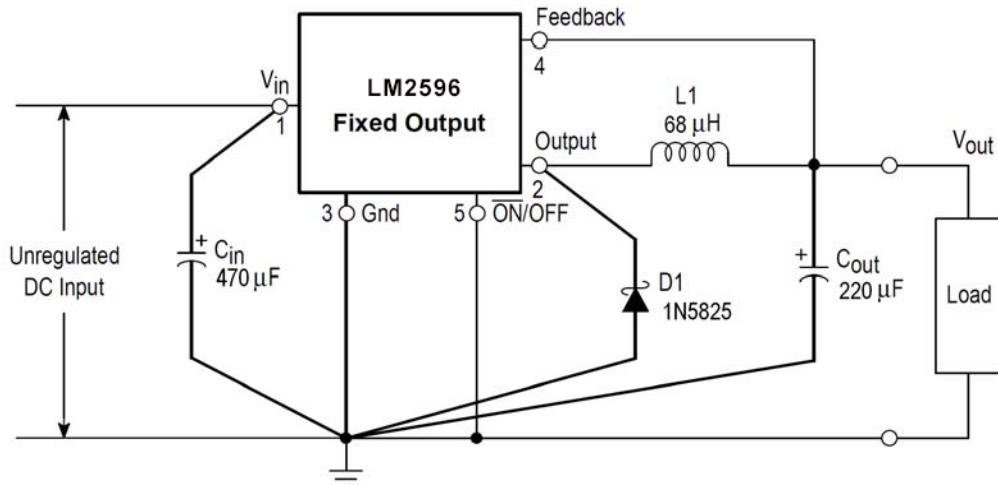

- C_{in} - 470 μ F, 75 V, Aluminium Electrolytic
- C_{out} - 220 μ F, 25 V, Aluminium Electrolytic
- D1 - Schottky, 1N5825
- L1 - 68 μ H, L38
- R1 - 2.0 k, 0.1%
- R2 - 6.12 k, 0.1%

Adjustable Output Voltage Versions

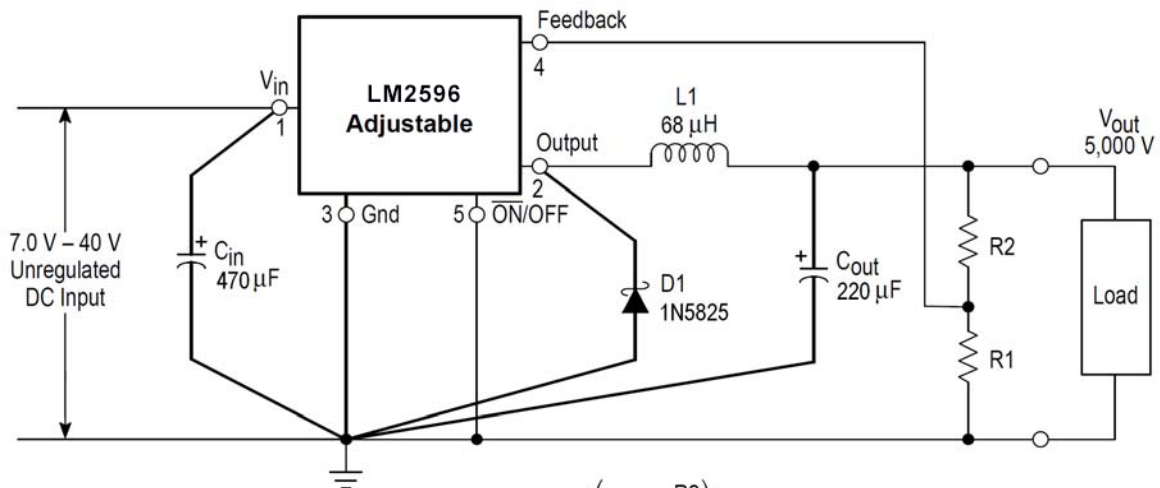

$$V_{out} = V_{ref} \left(1.0 + \frac{R2}{R1} \right)$$

$$R2 = R1 \left(\frac{V_{out}}{V_{ref}} - 1.0 \right)$$

Where $V_{ref} = 1.23$ V, R1 between 1.0 k and 5.0 k

12. Typical Application

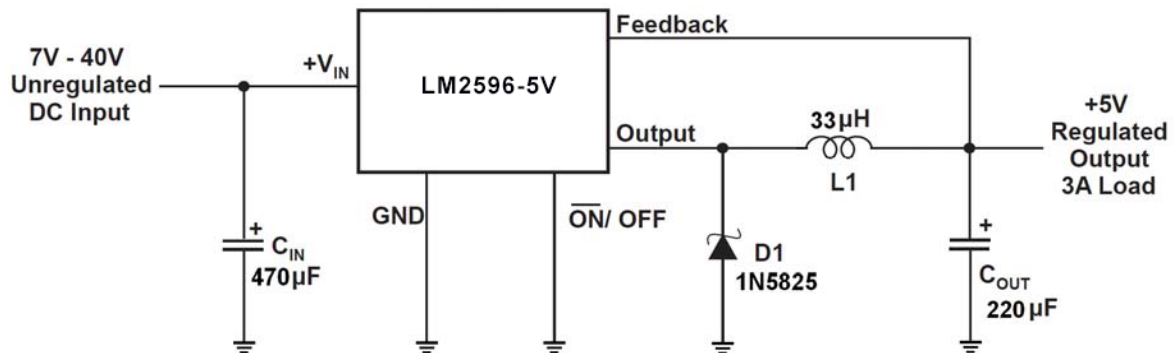

13. Application Information

Input Capacitor (C_{IN})

A low ESR aluminum or tantalum bypass capacitor is needed between the input pin and ground pin. It must be located near the regulator using short leads. This capacitor prevents large voltage transients from appearing at the input, and provides the instantaneous current needed each time the switch turns on.

The important parameters for the Input capacitor are the voltage rating and the RMS current rating. Because of the relatively high RMS currents flowing in a buck regulator's input capacitor, this capacitor should be chosen for its RMS current rating rather than its capacitance or voltage ratings, although the capacitance value and voltage rating are directly related to the RMS current rating.

The RMS current rating of a capacitor could be viewed as a capacitor's power rating. The RMS current flowing through the capacitor's internal ESR produces power which causes the internal temperature of the capacitor to rise. The RMS current rating of a capacitor is determined by the amount of current required to raise the internal temperature approximately 10°C above an ambient temperature of 105°C . The ability of the capacitor to dissipate this heat to the surrounding air will determine the amount of current the capacitor can safely sustain. Capacitors that are physically large and have a large surface area will typically have higher RMS current ratings. For a given capacitor value, a higher voltage electrolytic capacitor will be physically

larger than a lower voltage capacitor, and thus be able to dissipate more heat to the surrounding air, and therefore will have a higher RMS current rating.

The consequences of operating an electrolytic capacitor above the RMS current rating is a shortened operating life. The higher temperature speeds up the evaporation of the capacitor's electrolyte, resulting in eventual failure.

Selecting an input capacitor requires consulting the manufacturer's data sheet for maximum allowable RMS ripple current. For a maximum ambient temperature of 40°C , a general guideline would be to select a capacitor with a ripple current rating of approximately 50% of the DC load current. For ambient temperatures up to 70°C , a current rating of 75% of the DC load current would be a good choice for a conservative design. The capacitor voltage rating must be at least 1.25 times greater than the maximum input voltage, and often a much higher voltage capacitor is needed to satisfy the RMS current requirements.

Because of their small size and excellent performance, surface mount solid tantalum capacitors are often used for input bypassing, but several precautions must be observed. A small percentage of solid tantalum capacitors can short if the inrush current rating is exceeded. This can happen at turn on when the input voltage is suddenly applied, and of course, higher input voltages produce higher inrush currents. Several

capacitor manufacturers do a 100% surge current testing on their products to minimize this potential problem. If high turn on currents are expected, it may be necessary to limit this current by adding either some resistance or inductance before the tantalum capacitor, or select a higher voltage capacitor. As with aluminum electrolytic capacitors, the RMS ripple current rating must be sized to the load current. With most electrolytic capacitors, the capacitance value decreases and the ESR increases with lower temperatures and age. Paralleling a ceramic or solid tantalum capacitor will increase the regulator stability at cold temperatures. For maximum capacitor operating lifetime, the capacitor's RMS ripple current rating should be greater than

$$1.2 \times \left(\frac{t_{ON}}{T} \right) \times I_{LOAD}$$

Inductor Selection (L1)

All switching regulators have two basic modes of operation: continuous and discontinuous. The difference between the two types relates to the inductor current, whether it is flowing continuously, or if it drops to zero for a period of time in the normal switching cycle. Each mode has distinctively different operating characteristics, which can affect the regulator performance and requirements. Most switcher designs will operate in the discontinuous mode when the load current is low.

The LM2596 can be used for both continuous and discontinuous modes of operation. In many cases the preferred mode of operation is the continuous mode. It offers greater output power, lower peak switch, inductor and diode currents, and can have lower output ripple voltage. But it does require larger inductor values to keep the inductor current flowing continuously, especially at low output load currents and/or high input voltages.

To simplify the inductor selection process, an inductor selection guide (nomograph) was designed. This guide assumes that the regulator is operating in the

When $\frac{t_{ON}}{T} = \frac{V_{OUT}}{V_{IN}}$ for a buck regulator

and $\frac{t_{ON}}{T} = \frac{|V_{OUT}|}{|V_{OUT}| + V_{IN}}$ for a buck boost regulator.

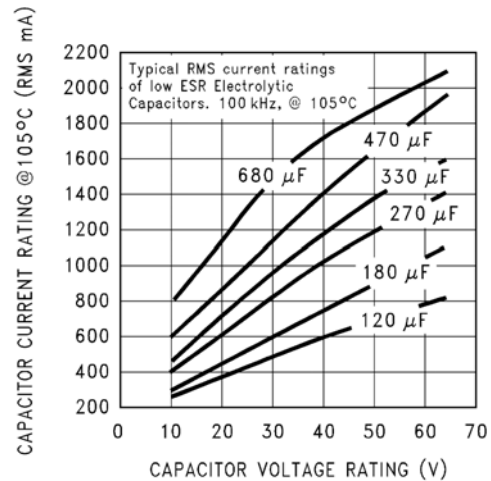

continuous mode, and selects an inductor that will allow a peak-to-peak inductor ripple current to be a certain percentage of the maximum design load current. This peak-to-peak inductor ripple current percentage is not fixed, but is allowed to change as different design load currents are selected.

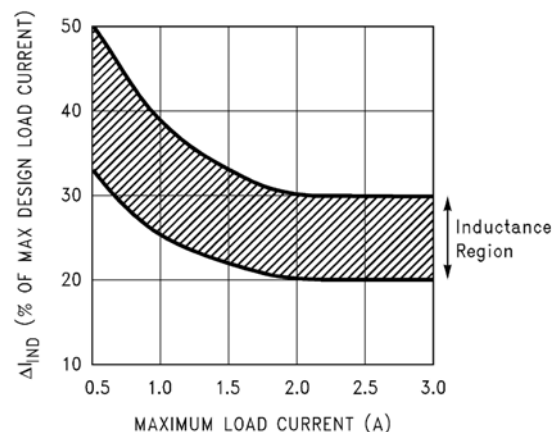

By allowing the percentage of inductor ripple current to increase for low load currents, the inductor value and size can be kept relatively low.

When operating in the continuous mode, the inductor current waveform ranges from a triangular to a sawtooth type of waveform (depending on the input

voltage), with the average value of this current waveform equal to the DC output load current.

Inductors are available in different styles such as pot core, toroid, E-core, bobbin core, etc., as well as different core materials, such as ferrites and powdered iron. The least expensive, the bobbin, rod or stick core, consists of wire wound on a ferrite bobbin.

This type of construction makes for an inexpensive inductor, but since the magnetic flux is not completely contained within the core, it generates more Electro-Magnetic Interference (EMI).

This magnetic flux can induce voltages into nearby printed circuit traces, thus causing problems with both the switching regulator operation and nearby sensitive circuitry, and can give incorrect scope readings because of induced voltages in the scope probe.

When multiple switching regulators are located on the same PC board, open core magnetics can cause interference between two or more of the regulator circuits, especially at high currents. A toroid or E-core

inductor (closed magnetic structure) should be used in these situations.

The inductors listed in the selection chart include ferrite E-core construction for Schott, ferrite bobbin core for Renco and Coilcraft, and powdered iron toroid for Pulse Engineering.

Exceeding an inductor's maximum current rating may cause the inductor to overheat because of the copper wire losses, or the core may saturate. If the inductor begins to saturate, the inductance decreases rapidly and the inductor begins to look mainly resistive (the DC resistance of the winding). This can cause the switch current to rise very rapidly and force the switch into a cycle-by-cycle current limit, thus reducing the DC output load current. This can also result in overheating of the inductor and/or the LM2596. Different inductor types have different saturation characteristics, and this should be kept in mind when selecting an inductor.

The inductor manufacturer's data sheets include current and energy limits to avoid inductor saturation.

Feed-forward Capacitor (C_{FF} , Adjustable Output Voltage Version)

A Feed-forward Capacitor C_{FF} , shown across R2 is used when the output voltage is greater than 10V or when C_{OUT} has a very low ESR. This capacitor adds

lead compensation to the feedback loop and increases the phase margin for better loop stability.

Catch Diode (D1)

Buck regulators require a diode to provide a return path for the inductor current when the switch is off. This must be a fast diode and must be located close to the LM2596 using short leads and short printed circuit traces. Because of their fast-switching speed and low forward voltage drop, Schottky diodes provide the best efficiency, especially in low output voltage switching

regulators (less than 5V). Ultra-fast Recovery, or High-Efficiency rectifiers are also a good choice, but some types with an abrupt turnoff characteristic may cause instability or EMI problems. Ultra-fast recovery diodes typically have reverse recovery times of 50 ns or less. Rectifiers such as the 1N5400 series are much too slow and should not be used.

Output Capacitor (C_{OUT})

An output capacitor is required to filter the output and provide regulator loop stability. Low impedance or low ESR Electrolytic or solid tantalum capacitors designed for switching regulator applications must be used. When selecting an output capacitor, the important

capacitor parameters are; the 100 kHz Equivalent Series Resistance (ESR), the RMS ripple current rating, voltage rating, and capacitance value. For the output capacitor, the ESR value is the most important parameter.

The output capacitor requires an ESR value that has an upper and lower limit. For low output ripple voltage, a low ESR value is needed. This value is determined by the maximum allowable output ripple voltage, typically 1% to 2% of the output voltage. But if the selected capacitor's ESR is extremely low, there is a possibility of an unstable feedback loop, resulting in an oscillation at the output. Using the capacitors listed in the tables, or

similar types, will provide design solutions under all conditions.

An aluminum electrolytic capacitor's ESR value is related to the capacitance value and its voltage rating. In most cases, higher voltage electrolytic capacitors

have lower ESR values. Often, capacitors with much higher voltage ratings may be needed to provide the low ESR values required for low output ripple voltage. The output capacitor for many different switcher designs often can be satisfied with only three or four different capacitor values and several different voltage ratings.

Electrolytic capacitors are not recommended for temperatures below -25°C . The ESR rises dramatically at cold temperatures and typically rises 3X @ -25°C and as much as 10X at -40°C .

Solid tantalum capacitors have a much better ESR spec for cold temperatures and are recommended for temperatures below -25°C .

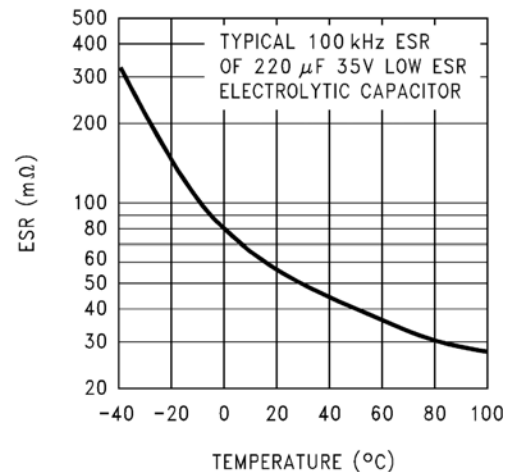
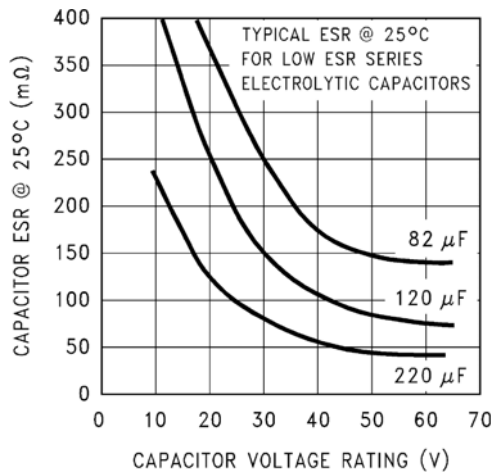

Output Voltage Ripple and Transients

The output voltage of a switching power supply operating in the continuous mode will contain a sawtooth ripple voltage at the switcher frequency, and may also contain short voltage spikes at the peaks of the sawtooth waveform.

The output ripple voltage is a function of the inductor sawtooth ripple current and the ESR of the output capacitor. A typical output ripple voltage can range from approximately 0.5% to 3% of the output voltage. To obtain low ripple voltage, the ESR of the output capacitor must be low, however, caution must be exercised when using extremely low ESR capacitors because they can affect the loop stability, resulting in

oscillation problems. If very low output ripple voltage is needed (less than 20 mV), a post ripple filter is recommended.

The inductance required is typically between $1\mu\text{H}$ and $5\mu\text{H}$, with low DC resistance, to maintain good load regulation. A low ESR output filter capacitor is also required to assure good dynamic load response and ripple reduction. The ESR of this capacitor may be as low as desired, because it is out of the regulator feedback loop. When observing output ripple with a scope, it is essential that a short, low inductance scope probe ground connection be used. Most scope probe manufacturers provide a special probe terminator

which is soldered onto the regulator board, preferable at the output capacitor. This provides a very short scope ground thus eliminating the problems associated with the 3 inch ground lead normally provided with the probe, and provides a much cleaner and more accurate picture of the ripple voltage waveform.

The voltage spikes are caused by the fast-switching action of the output switch and the diode, and the parasitic inductance of the output filter capacitor, and its associated wiring. To minimize these voltage spikes, the output capacitor should be designed for switching regulator applications, and the lead lengths must be kept very short. Wiring inductance, stray capacitance, as well as the scope probe used to evaluate these transients, all contribute to the amplitude of these spikes.

When a switching regulator is operating in the continuous mode, the inductor current waveform ranges from a triangular to a sawtooth type of waveform (depending on the input voltage). For a given input and output voltage, the peak-to-peak amplitude of this inductor current waveform remains constant. As the load current increases or decreases, the entire sawtooth current waveform also rises and falls. The average value (or the center) of this current waveform is equal to the DC load current.

If the load current drops to a low enough level, the bottom of the sawtooth current waveform will reach zero, and the switcher will smoothly change from a continuous to a discontinuous mode of operation. Most switcher designs (irregardless how large the inductor value is) will be forced to run discontinuous if the output is lightly loaded. This is a perfectly acceptable mode of operation.

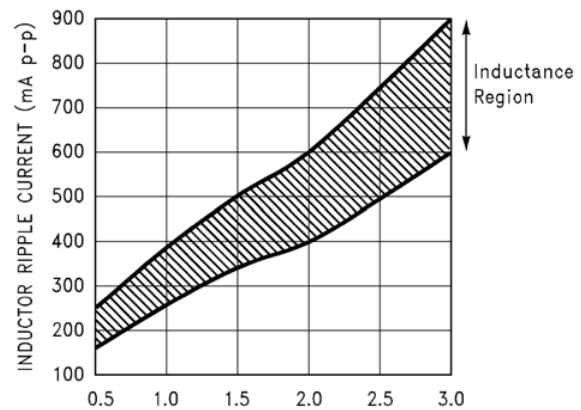

In a switching regulator design, knowing the value of the peak-to-peak inductor ripple current (ΔI_{IND}) can be useful for determining a number of other circuit parameters. Parameters such as, peak inductor or peak switch current, minimum load current before the circuit becomes discontinuous, output ripple voltage and output capacitor ESR can all be calculated from the peak-to-peak ΔI_{IND} . When the inductor nomographs are used to select an inductor value, the peak-to-peak inductor ripple current can immediately be determined. the range of (ΔI_{IND}) that can be expected for different load currents. The curve also shows how the peak-to-peak inductor ripple current (ΔI_{IND}) changes as you go from the lower border to the upper border (for a given load current) within an inductance region. The upper border represents a higher input voltage, while the lower border represents a lower input voltage.

These curves are only correct for continuous mode operation, and only if the inductor selection guides are used to select the inductor value. Consider the following example:

$V_{OUT} = 5V$, maximum load current of 2.5A

$V_{IN} = 12V$, nominal, varying between 10V and 16V.

That the vertical line for a 2.5A load current, and the horizontal line for the 12V input voltage intersect approximately midway between the upper and lower borders of the 33 μ H inductance region. A 33 μ H inductor will allow a peak-to-peak inductor current (ΔI_{IND}) to flow that will be a percentage of the maximum load current. follow the 2.5A line approximately midway

into the inductance region, and read the peak-to-peak inductor ripple current (ΔI_{IND}) on the left hand axis (approximately 620mA pp).

As the input voltage increases to 16V, it approaches the upper border of the inductance region, and the inductor ripple current increases. It can be seen that for a load current of 2.5A, the peak-to-peak inductor ripple current (ΔI_{IND}) is 620mA with 12V in, and can range from 740mA at the upper border (16V in) to 500mA at the lower border (10V in).

Once the ΔI_{IND} value is known, the following formulas

can be used to calculate additional information about the switching regulator circuit.

$$1. \text{ Peak Inductor or peaks switch current} = \left(I_{LOAD} + \frac{\Delta I_{IND}}{2} \right) = \left(2.5A + \frac{0.62}{2} \right) = 2.81A$$

$$2. \text{ Minimum load current before the circuit becomes discontinuous} = \frac{\Delta I_{IND}}{2} = \frac{0.62}{2} = 0.31A$$

$$3. \text{ Output Ripple Voltage} = (\Delta I_{IND}) \times (\text{ESR of } C_{OUT}) = 0.62A \times 0.1\Omega = 62 \text{ mV p-p}$$

$$4. \text{ ESR of } C_{OUT} = \text{Output Ripple Voltage} (\Delta V_{OUT}) / \Delta I_{IND} = 0.062V / 0.62A = 0.1\Omega$$

Feedback Connection

The LM2596 (fixed voltage versions) feedback pin must be wired to the output voltage point of the switching power supply. When using the adjustable version, physically locate both output voltage programming resistors near the LM2596 to avoid picking up unwanted noise. Avoid using resistors greater than 100k Ω because of the increased chance of noise pickup.

\overline{ON} / OFF Input

For normal operation, the \overline{ON} / OFF pin should be grounded or driven with a low-level TTL voltage (typically below 1.6V). To put the regulator into standby mode, drive this pin with a high-level TTL or CMOS signal. The \overline{ON} / OFF pin can be safely pulled up to +V_{IN} without a resistor in series with it. The \overline{ON} / OFF pin should not be left open.

Thermal Considerations

The LM2596 is available in two packages. The TO220T-5L package needs a heat sink under most conditions. The size of the heatsink depends on the input voltage, the output voltage, the load current and the ambient temperature. LM2596 junction temperature rises above ambient temperature for a 3A load and different input and output voltages. The data for these curves was taken with the LM2596 (TO220T package) operating as a buck switching regulator in an ambient temperature of 25°C (still air). These temperature rise numbers are all approximate and there are many factors that can affect these temperatures. Higher ambient temperatures require more heat sinking. The TO263-5L surface mount package tab is designed to be soldered to the copper on a printed circuit board. The copper and the board are the heat sink for this package and the other heat

producing components, such as the catch diode and inductor. The PC board copper area that the package is soldered to should be at least 0.4 in², and ideally should have 2 or more square inches of 2 oz. (0.0028 in.) copper. Additional copper area improves the thermal characteristics, but with copper areas greater than approximately 6 in², only small improvements in heat dissipation are realized. If further thermal improvements are needed, double sided, multilayer PC board with large copper areas and/or airflow are recommended.

LM2596 (TO263 package) junction temperature rise above ambient temperature with a 2A load for various input and output voltages. This data was taken with the circuit operating as a buck switching regulator with all components mounted on a PC board to simulate the junction temperature under actual operating conditions.

This curve can be used for a quick check for the approximate junction temperature for various conditions, but be aware that there are many factors that can affect the junction temperature. When load currents higher than 2A are used, double sided or multilayer PC boards with large copper areas and/or airflow might be needed, especially for high ambient temperatures and high output voltages.

For the best thermal performance, wide copper traces and generous amounts of printed circuit board copper should be used in the board layout. (One exception to this is the output (switch) pin, which should **not** have large areas of copper.) Large areas of copper provide the best transfer of heat (lower thermal resistance) to the surrounding air, and moving air lowers the thermal resistance even further.

Package thermal resistance and junction temperature

rise numbers are all approximate, and there are many factors that will affect these numbers. Some of these factors include board size, shape, thickness, position, location, and even board temperature. Other factors are, trace width, total printed circuit copper area, copper thickness, single- or double-sided, multilayer board and the amount of solder on the board. The effectiveness of the PC board to dissipate heat also depends on the size, quantity and spacing of other components on the board, as well as whether the surrounding air is still or moving. Furthermore, some of these components such as the catch diode will add heat to the PC board and the heat can vary as the input voltage changes. For the inductor, depending on the physical size, type of core material and the DC resistance, it could either act as a heat sink taking heat away from the board, or it could add heat to the board.

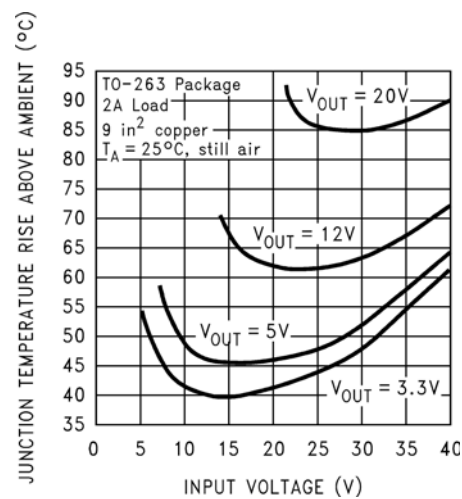
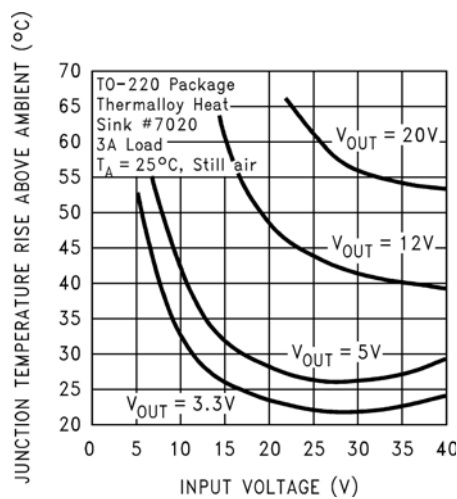
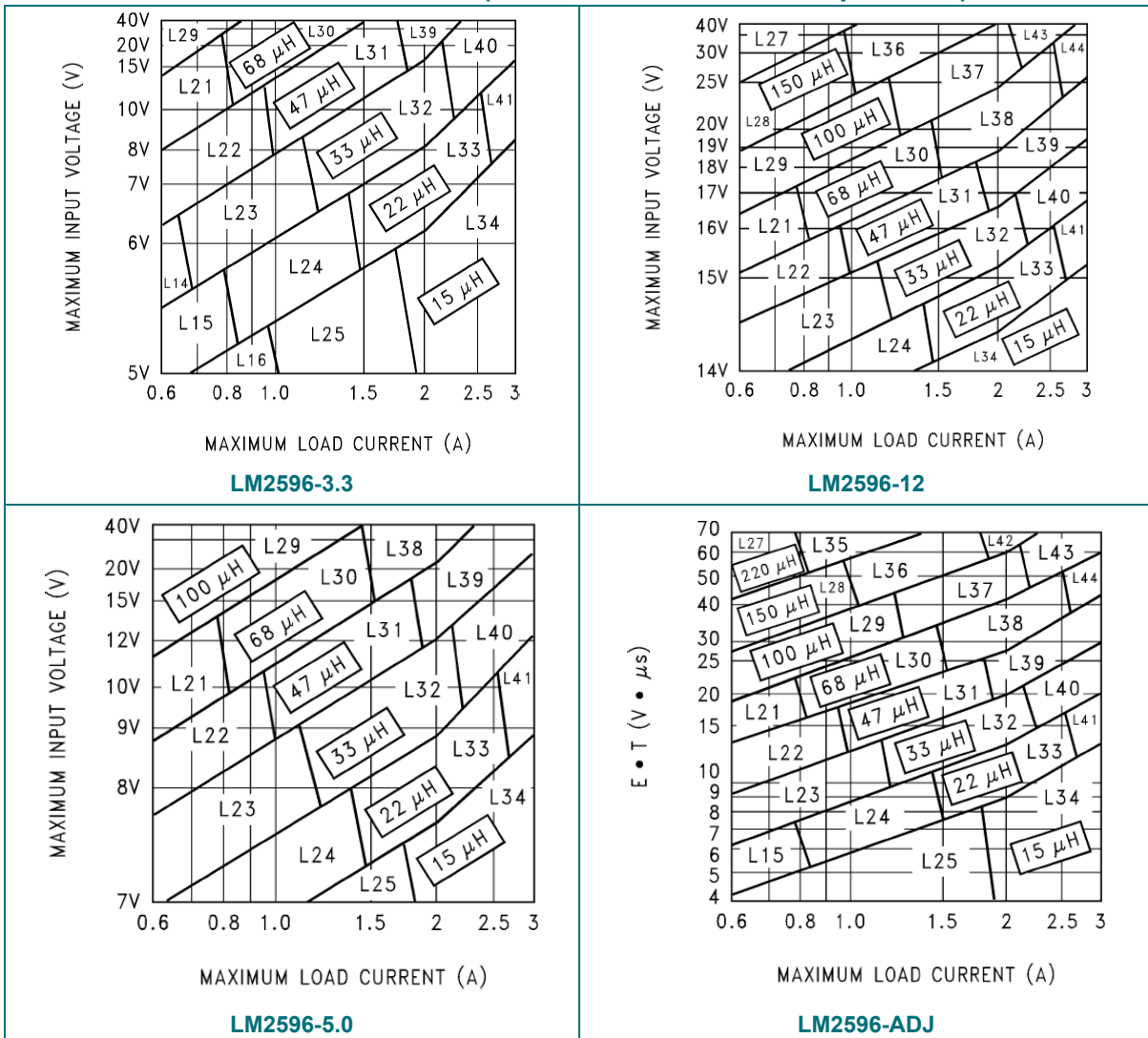

Table 1. Junction Temperature Rise

	TO220T-5L	TO263-5L
Capacitors	Through hole electrolytic	Surface mount tantalum, molded "D" size
Inductor	Through hole, Renco	Surface mount, Pulse Engineering, 68μH
Diode	Through hole, 5A 40V, Schottky	Surface mount, 5A 40V, Schottky
PC Board	3 square inches single sided 2 oz. copper (0.0028")	9 square inches single sided 2 oz. copper (0.0028")

Inductor Value Selection Guides (For Continuous Mode Operation)

	Inductance (μ H)	Current (A)	Schott		Renco		Pulse Engineering		Coilcraft
			Through Hole	Surface Mount	Through Hole	Surface Mount	Through Hole	Surface Mount	Surface Mount
L15	22	0.99	67148350	67148460	RL-1284-22-43	RL1500-22	PE-53815	PE-53815-S	DO3308-223
L21	68	0.99	67144070	67144450	RL-5471-5	RL1500-68	PE-53821	PE-53821-S	DO3316-683
L22	47	1.17	67144080	67144460	RL-5471-6	—	PE-53822	PE-53822-S	DO3316-473
L23	33	1.40	67144090	67144470	RL-5471-7	—	PE-53823	PE-53823-S	DO3316-333
L24	22	1.70	67148370	67148480	RL-1283-22-43	—	PE-53824	PE-53825-S	DO3316-223
L25	15	2.10	67148380	67148490	RL-1283-15-43	—	PE-53825	PE-53824-S	DO3316-153
L26	330	0.80	67144100	67144480	RL-5471-1	—	PE-53826	PE-53826-S	DO5022P-334
L27	220	1.00	67144110	67144490	RL-5471-2	—	PE-53827	PE-53827-S	DO5022P-224
L28	150	1.20	67144120	67144500	RL-5471-3	—	PE-53828	PE-53828-S	DO5022P-154
L29	100	1.47	67144130	67144510	RL-5471-4	—	PE-53829	PE-53829-S	DO5022P-104
L30	68	1.78	67144140	67144520	RL-5471-5	—	PE-53830	PE-53830-S	DO5022P-683
L31	47	2.20	67144150	67144530	RL-5471-6	—	PE-53831	PE-53831-S	DO5022P-473
L32	33	2.50	67144160	67144540	RL-5471-7	—	PE-53932	PE-53932-S	DO5022P-333
L33	22	3.10	67148390	67148500	RL-1283-22-43	—	PE-53933	PE-53933-S	DO5022P-223
L34	15	3.40	67148400	67148790	RL-1283-15-43	—	PE-53934	PE-53934-S	DO5022P-153
L35	220	1.70	67144170	—	RL-5473-1	—	PE-53935	PE-53935-S	—
L36	150	2.10	67144180	—	RL-5473-4	—	PE-54036	PE-54036-S	—
L37	100	2.50	67144190	—	RL-5472-1	—	PE-54037	PE-54037-S	—
L38	68	3.10	67144200	—	RL-5472-2	—	PE-54038	PE-54038-S	—
L39	47	3.50	67144210	—	RL-5472-3	—	PE-54039	PE-54039-S	—
L40	33	3.50	67144220	67148290	RL-5472-4	—	PE-54040	PE-54040-S	—
L41	22	3.50	67144230	67148300	RL-5472-5	—	PE-54041	PE-54041-S	—
L42	150	2.70	67148410	—	RL-5473-4	—	PE-54042	PE-54042-S	—
L43	100	3.40	67144240	—	RL-5473-2	—	PE-54043	—	—
L44	68	3.40	67144250	—	RL-5473-3	—	PE-54044	—	—

Fig. 1. Inductor Selection Guide

V_R	Schottky		Fast Recovery	
	3A	4A–6A	3A	4A–6A
20V	1N5820 MBR320P SR302	1N5823	The following diodes are all rated to 100V 31DF1 HER302	The following diodes are all rated to 100V 50WF10 MUR410 HER602
30V	1N5821 MBR330 31DQ03 SR303	50WQ03 1N5824		
40V	1N5822 MBR340 31DQ04 SR304	MBR340 50WQ04 1N5825		
50V	MBR350 31DQ05 SR305	50WQ05		
60V	MBR360 DQ06 SR306	50WR06 50SQ060		

Fig. 2. Diode Selection Guide

14. Package Outlines

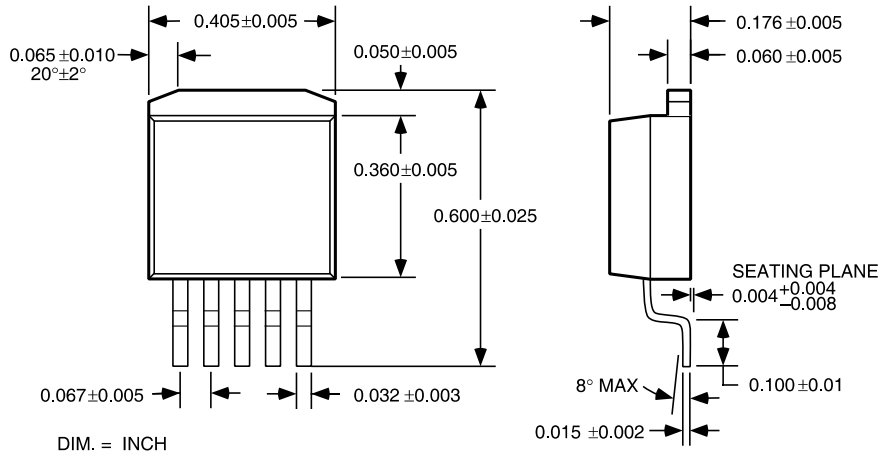
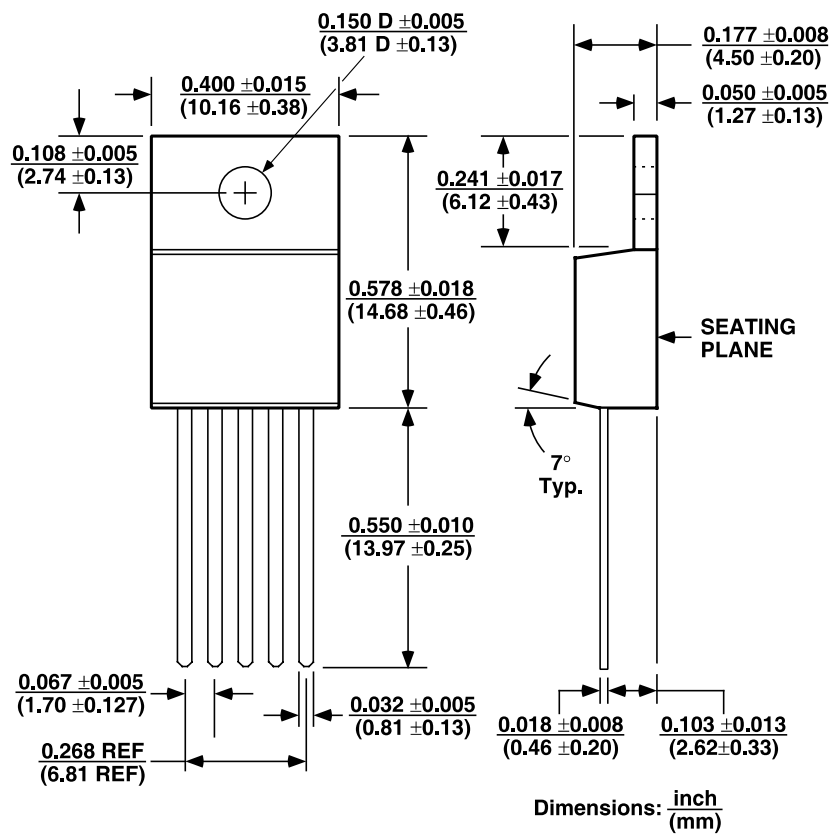
TO-263-5L

TO-220-5L

15. Disclaimers

Limited warranty and liability

Information in this document is believed to be accurate and reliable. However, Fuli hao does not give any representations or warranties, expressed or implied, as to the accuracy or completeness of such information and shall have no liability for the consequences of use of such information. It is the customer's responsibility to validate that a particular product with the properties described in the product specification is suitable for use in a particular application.

Suitability for use

Fuli hao products are designed for specific applications and should not be used for any purpose (including, without limitation, automotive, aerospace, medical, life-saving applications, or any other application which requires especially high reliability for the prevention of such defect as may directly cause damage to the third party's life, body or property) not expressly set forth in applicable Fuli hao product documentation.

Right to make changes

Fuli hao reserves the right to make changes to information published in this document, including without limitation specifications and product descriptions, at any time and without notice. Reproduction in whole or in part is prohibited without the prior written consent of the copyright owner. Fuli hao takes no responsibility for the content in this document if provided by an information source outside of Fuli hao. This document supersedes and replaces all information supplied prior to the publication hereof.