

Descriptions

The LM317 is an adjustable 3-terminal positive voltage regulator capable of supplying in excess of 1.5 A over an output voltage range of 1.2 V to 37 V. This voltage regulator is exceptionally easy to use and requires only two external resistors to set the output voltage. Further, it employs internal current limiting, thermal shutdown and safe area compensation, making it essentially blow-out proof.

The LM317 serves a wide variety of applications including local, on card regulation. This device can also be used to make a programmable output regulator, or by connecting a fixed resistor between the adjustment and output, the LM317 can be used as a precision current regulator.

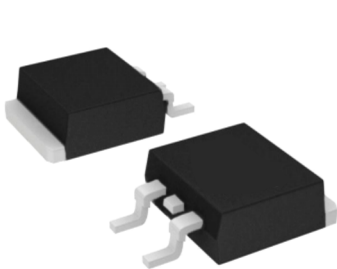

TO-263-2L

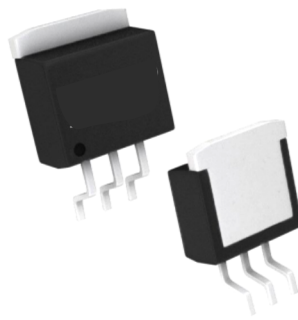

TO-263-3L

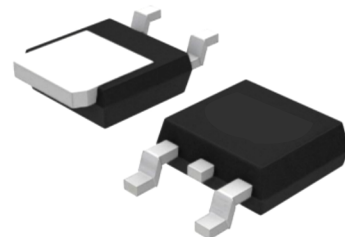

TO-252-2L

Feature

- Typical 1% Output Voltage Tolerance
- Output voltage adjustable from 1.25V ~37V
- Output current in excess of 1.5A
- Internal short circuit protection
- Internal over temperature protection
- Output transistor safe area compensation
- Internal short circuit protection

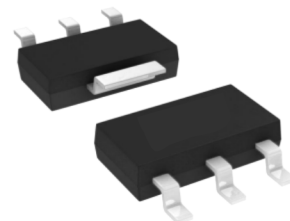

SOT-223

Applications

- PC Motherboard
- LCD Monitor
- Graphic Card
- DVD Player
- Network Interface Card/Switch
- Telecom Equipment
- Printer and other Peripheral Equipmen

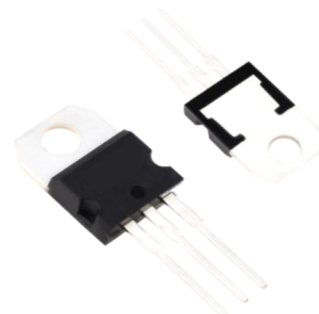

TO-220

Ordering Information

Product Model	Package Type	Marking	Packing	Packing Qty
XBLW LM317S	SOT-223	LM317S	Tape	2500Pcs/Reel
XBLW LM317T	TO-220	LM317T	Tube	1000Pcs/Box
XBLW LM317MDTR	TO-252-2L	LM317	Tape	2500Pcs/Reel
XBLW LM317CDTR	TO-263-2L	LM317C	Tape	800Pcs/Reel
XBLW LM317C3DTR	TO-263-3L	LM317C	Tape	800Pcs/Reel

Pin Configuration (Top View)

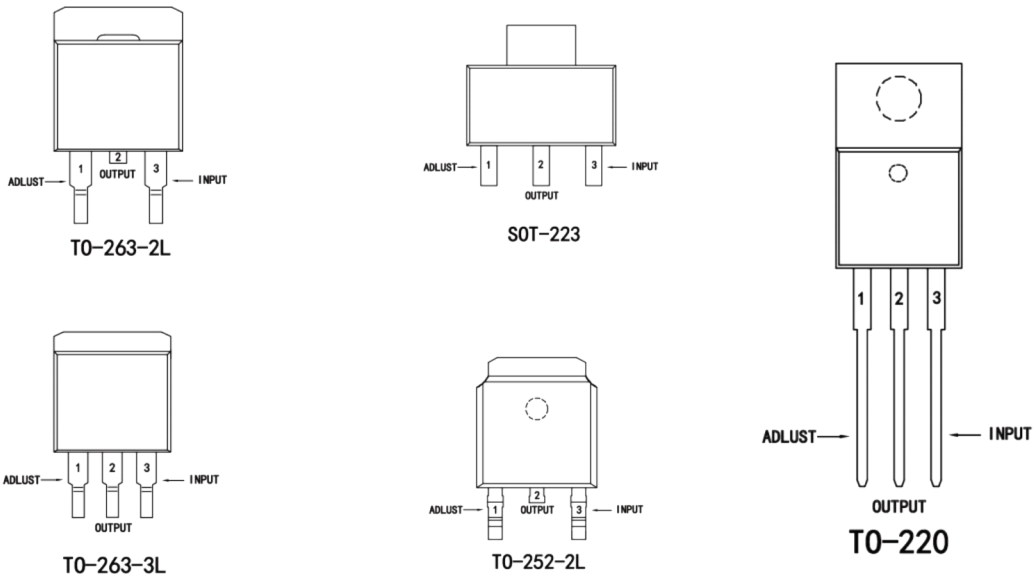

Pin Functions

PIN		I/O	DESCRIPTION
NAME	NO.		
ADJUST	1	I	Output voltage adjustment pin. Connect to a resistor divider to set V_o
INPUT	3	I	Supply input pin
OUTPUT	2	O	Voltage output pin

BLOCK DIAGRAM

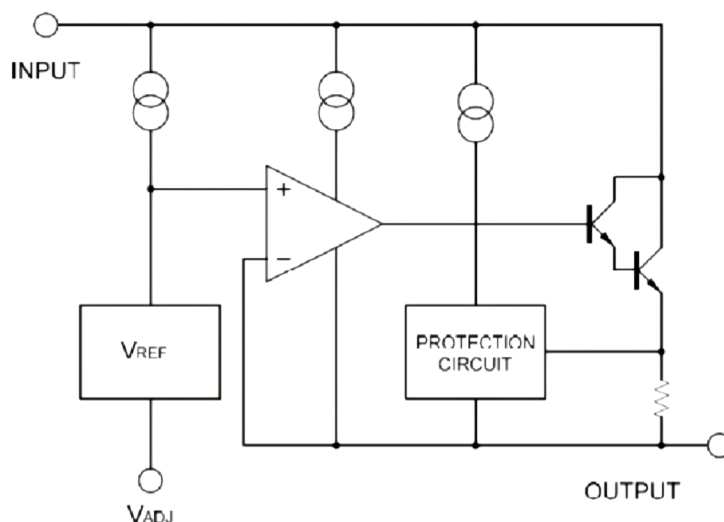

APPLICATION CIRCUIT

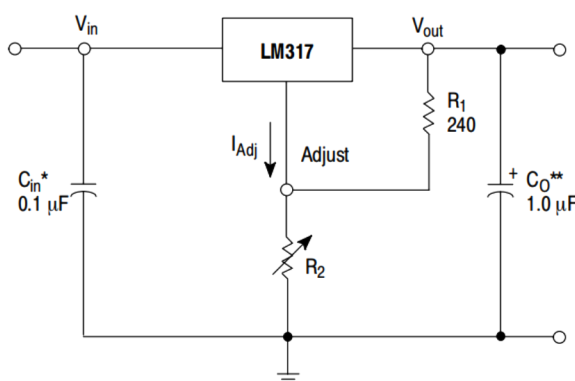

* C_{in} is required if regulator is located an appreciable distance from power supply filter.
 ** C_o is not needed for stability, however, it does improve transient response.

$$V_{out} = 1.25 V \left(1 + \frac{R_2}{R_1} \right) + I_{Adj} R_2$$

Since I_{Adj} is controlled to less than 100 μA , the error associated with this term is negligible in most applications.

ABSOLUTE MAXIMUM RATINGS (Ta=25°C) *

Characteristic	Symbol	Min.	Max.	Unit
Input - Output Voltage Difference	Vin-Vout		37	V
Power Dissipation	Pd	Internal limited		
Maximum junction temperature	T _J		150	°C
Storage temperature	T _S	-40	150	°C
Lead temperature (soldering, 10sec)	T _{LEAD}		260	°C
ESD (human body model)	ESD		4000	V

*: Absolute maximum ratings are stress ratings only and functional device operation is not implied. The device could be damaged beyond Absolute maximum ratings.

Recommended Operating Conditions

over operating free-air temperature range (unless otherwise noted)

		MIN	MAX	UNIT
Operating Temperature Range	LM317	-20	125	°C

ELECTRICAL CHARACTERISTICS

($V_{IN}-V_{OUT}=5V$, $I_{OUT}=10mA$, $T_a=25^\circ C$, unless otherwise specified.) *

Characteristics	Test conditions	Symbol	Min.	Typ.	Max.	Unit
Reference voltage	$10\text{ mA} \leq I_{OUT} \leq 1.5\text{ A}$, $3\text{ V} \leq (V_{IN} - V_{OUT}) \leq 37\text{ V}$, $P_D \leq 2.0\text{ W}$	V_{REF}	1.2	1.25	1.3	V
Line regulation	$3\text{ V} \leq V_{IN} - V_{OUT} \leq 37\text{ V}$	S_V		0.01	0.04	%/V
Load regulation	$0\text{ mA} \leq I_{OUT} \leq 1.5\text{ A}$	S_I		0.2	0.4	%
Adjust pin current		I_{Adj}		50	100	μA
Adjust pin current change	$3\text{ V} \leq V_{IN} - V_{OUT} \leq 37\text{ V}$, $10\text{ mA} \leq I_{OUT} \leq 1.5\text{ A}$, $P_D \leq 2.0\text{ W}$	I_{Adj}		0.2	5.0	μA
Minimum load current	$V_{IN} - V_{OUT} = 37\text{ V}$	I_{Lmin}		3.5	10	mA
Ripple rejection	$f = 120\text{ Hz}$, $C_{OUT} = 1\mu\text{F}$ tantalum, $(V_{IN} - V_{OUT}) = 3\text{ V}$, $I_{OUT} = 1.5\text{ A}$	RR	60	75		dB
Temperature stability	$T_{MIN} \leq T_J \leq T_{MAX}$			0.7		%
RMS output noise (% of V_{OUT})	$T_a = 25^\circ\text{C}$, $10\text{ Hz} \leq f \leq 10\text{ kHz}$	en		0.003		%
Thermal resistance, Junction to case	SOT223	θ_{JC}		23		$^\circ\text{C/W}$
	TO252			12		
	TO220			5		
	TO263			5		
Thermal resistance, Junction to Ambient	SOT223	θ_{JA}		165		$^\circ\text{C/W}$
	TO252			112		
	TO220			54		
	TO263			64		
Thermal shutdown hysteresis		Thys		25		$^\circ\text{C/W}$

*: Maximum Power Dissipation is Package Type and Case Temperature dependent.

CHARACTERISTICS CURVES

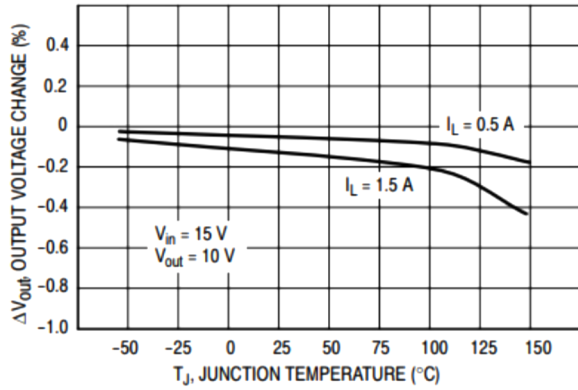

Load Regulation

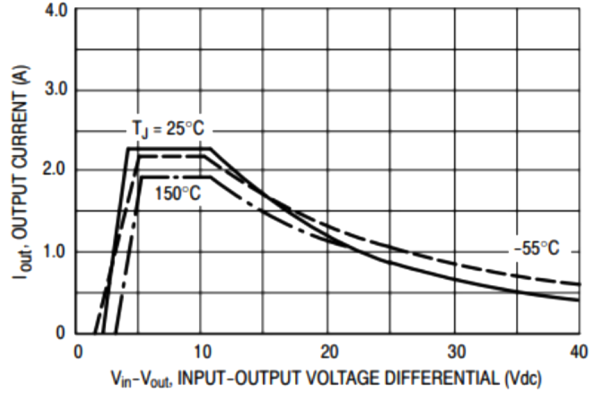

Current Limit

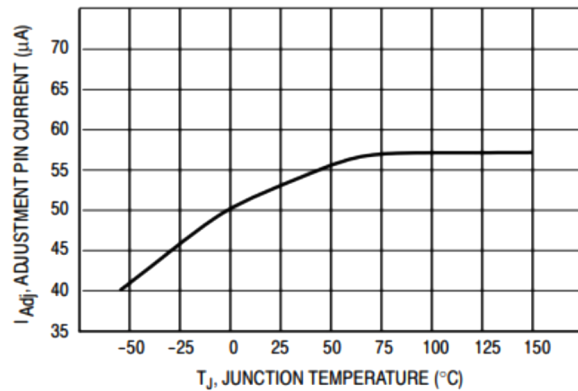

Adjustment Pin Current

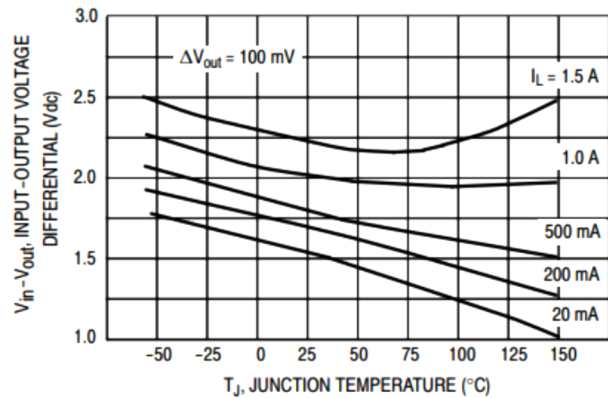

Dropout Voltage

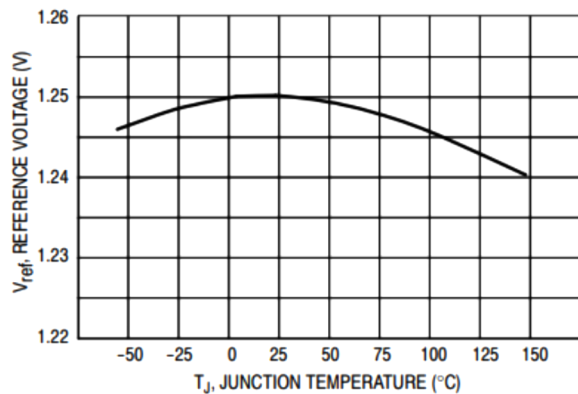

Temperature Stability

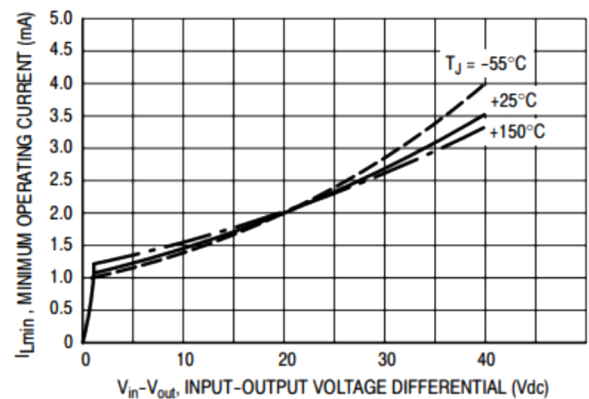

Minimum Operating Current

CHARACTERISTICS CURVES

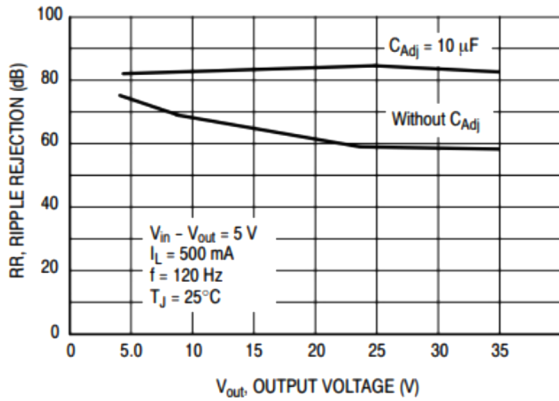

Ripple Rejection versus Output Voltage

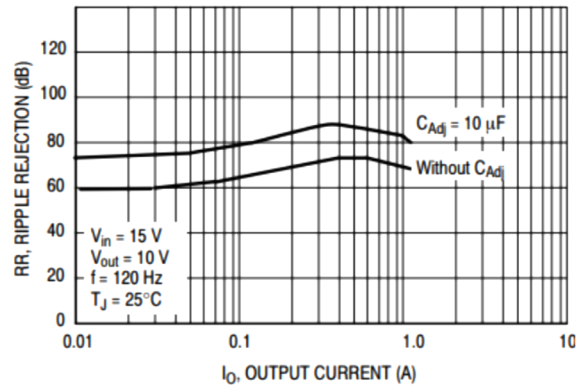

Ripple Rejection versus Output Current

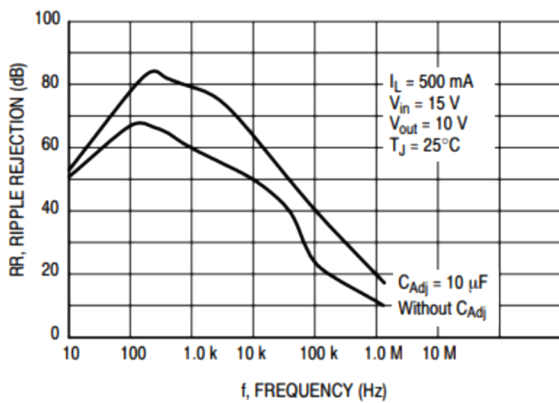

Ripple Rejection versus Frequency

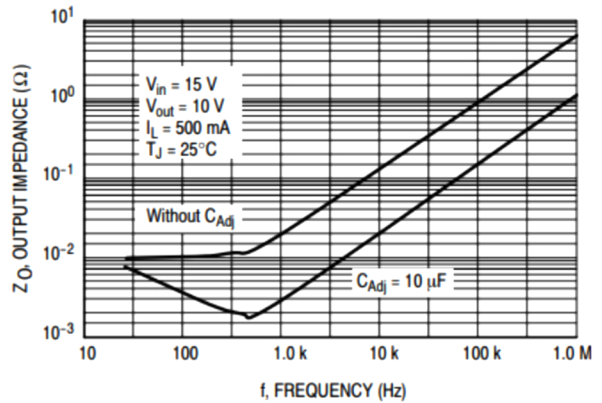

Output Impedance

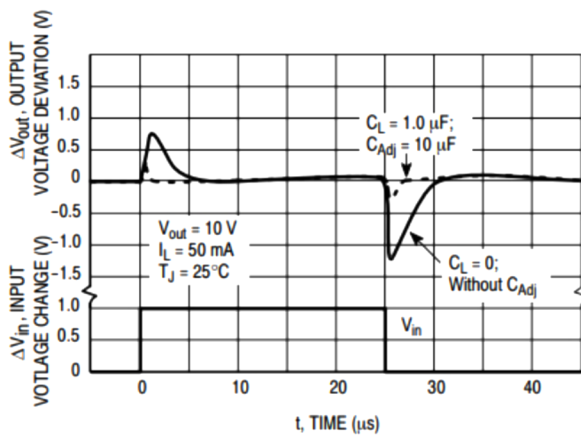

Line Transient Response

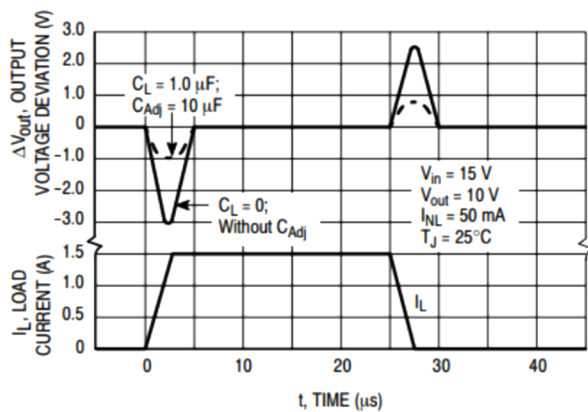

Load Transient Response

Package Information

· SOT-223

Size Symbol	Dimensions In Millimeters		Size Symbol	Dimensions In Inches	
	Min (mm)	Max (mm)		Min (in)	Max (in)
A		1.800	A		0.071
A1	0.020	0.100	A1	0.001	0.004
A2	1.500	1.700	A2	0.059	0.067
b	0.660	0.840	b	0.026	0.033
b1	2.900	3.100	b1	0.114	0.122
c	0.230	0.350	c	0.009	0.014
D	6.300	6.700	D	0.248	0.264
E	6.700	7.300	E	0.264	0.287
E1	3.300	3.700	E1	0.130	0.146
e	2.300 (BSC)		e	0.091 (BSC)	
L	0.750		L	0.030	
θ	0°	10°	θ	0°	10°

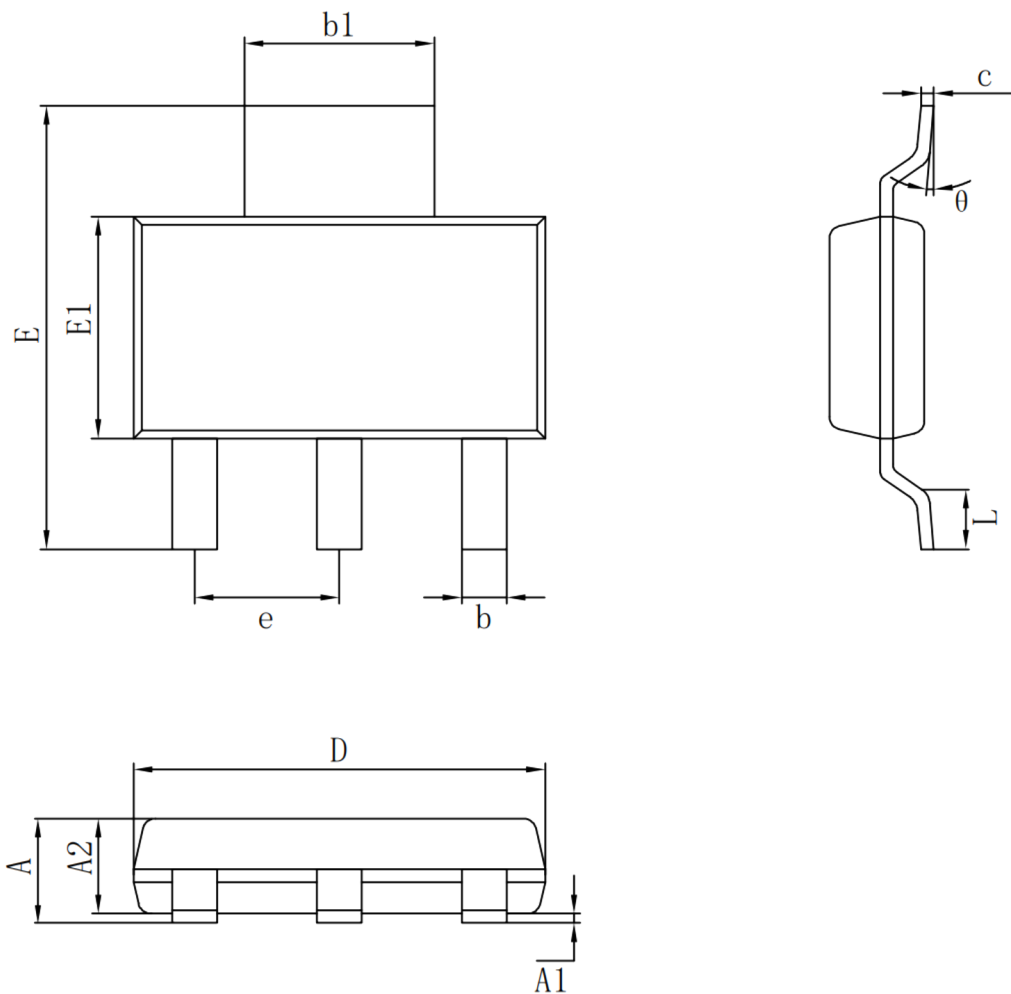

• T0-220

Symbol	Dimensions In Millimeters		Symbol	Dimensions In Inches	
	Min (mm)	Max (mm)		Min (in)	Max (in)
A	4.150	4.250	A	0.163	0.167
C	0.985	1.015	C	0.039	0.040
C1	0.365	0.395	C1	0.014	0.016
D	10.03	10.10	D	0.395	0.398
E	15.02	15.75	E	0.591	0.620
Φ	3.700	3.900	Φ	0.146	0.154
e	2.540 (TYP)		e	0.100 (TYP)	
b	0.770	0.830	b	0.030	0.033
b1	1.230	1.290	b1	0.048	0.051
L	13.00	14.00	L	0.512	0.551
L1	3.500	3.900	L1	0.138	0.154

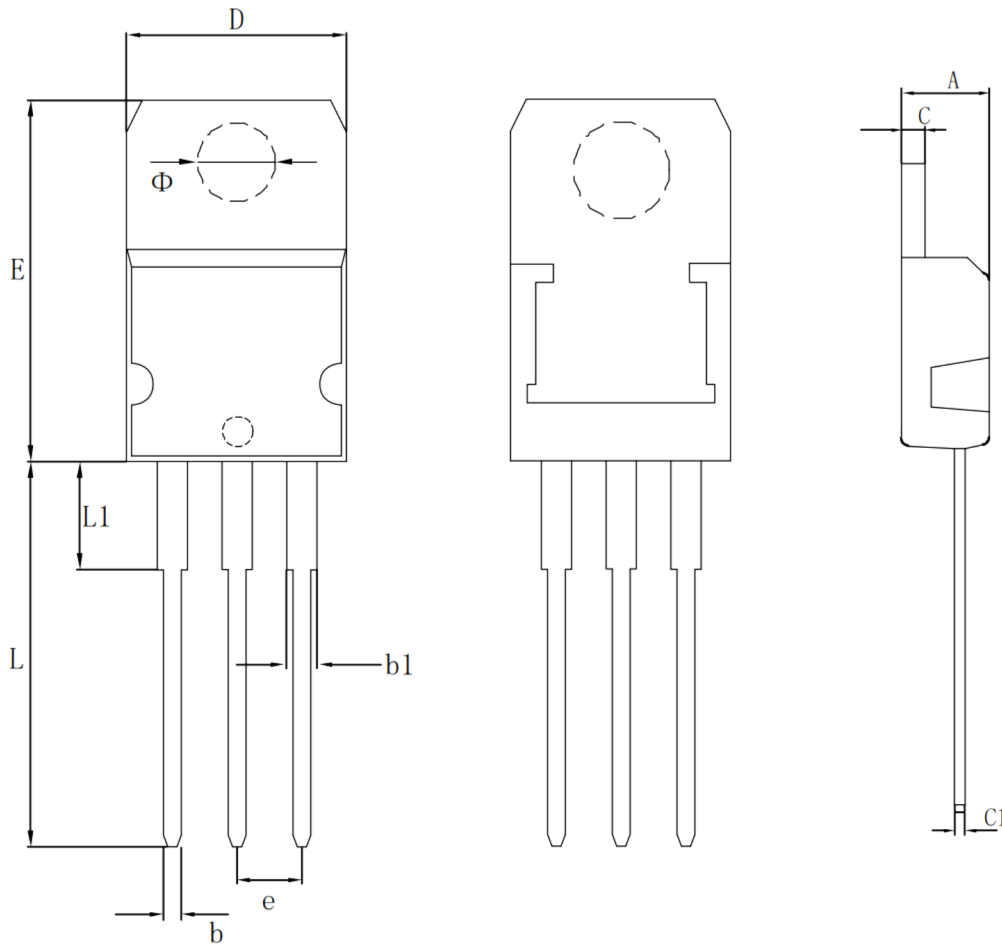

· T0-252-2L

Symbol	Dimensions In Millimeters		Symbol	Dimensions In Inches	
	Min (mm)	Max (mm)		Min (mm)	Max (mm)
A	2.200	2.400	A	0.087	0.094
A1	0.000	0.127	A1	0.000	0.005
B	1.350	1.650	B	0.053	0.065
b	0.500	0.700	b	0.020	0.028
b1	0.700	0.900	b1	0.028	0.035
c	0.430	0.580	c	0.017	0.023
c1	0.430	0.580	c1	0.017	0.023
D	6.350	6.500	D	0.250	0.262
D1	5.200	5.400	D1	0.205	0.213
E	5.400	5.700	E	0.213	0.224
e	2.300 (TYP)		e	0.091 (TYP)	
e1	4.500	4.700	e1	0.177	0.185
L	9.500	9.900	L	0.374	0.390
L1	2.550	2.900	L1	0.100	0.114
L2	1.400	1.780	L2	0.055	0.070

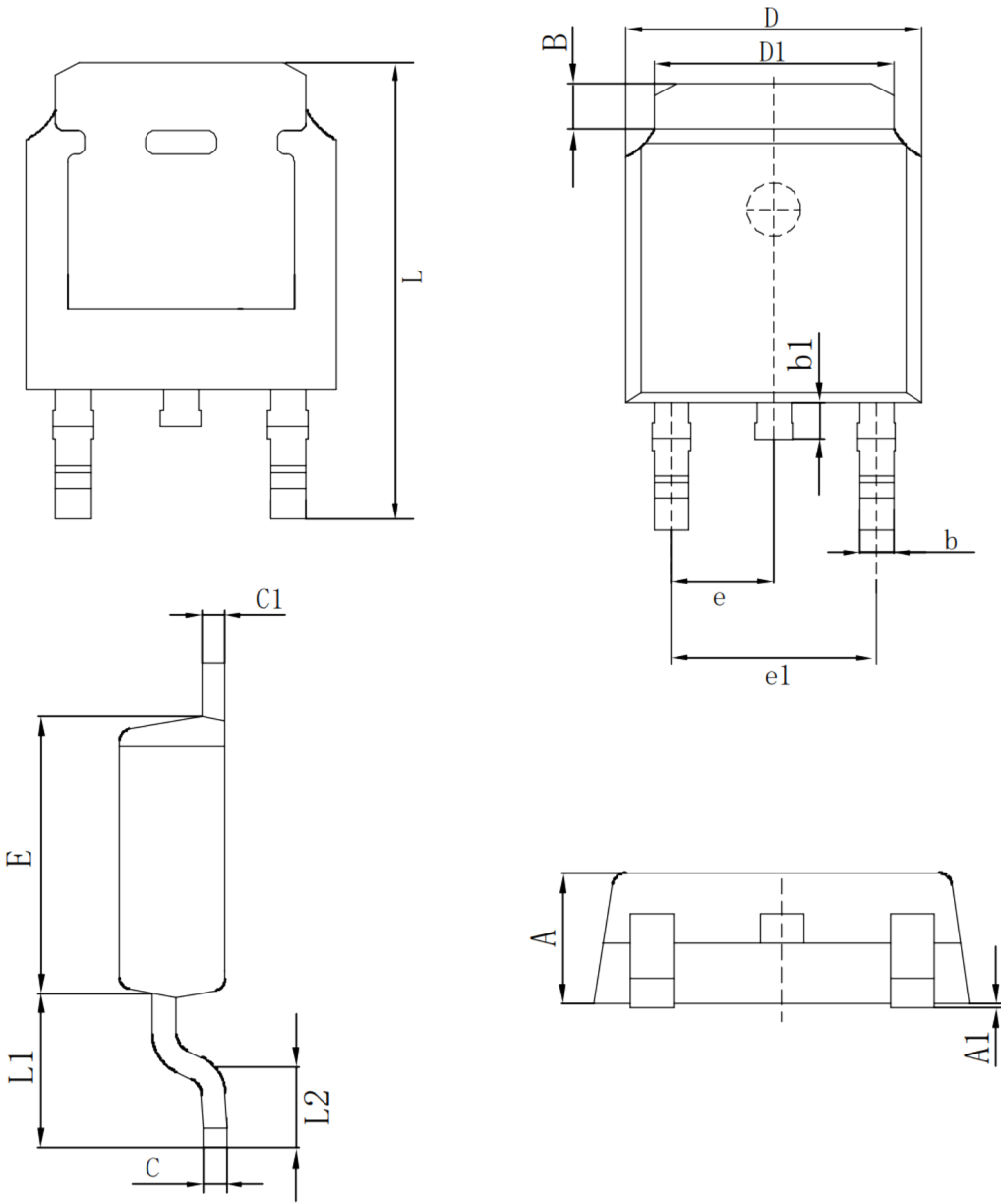

· T0-263-2L

Symbol	Size	Dimensions In Millimeters		Symbol	Size	Dimensions In Inches	
		Min (mm)	Max (mm)			Min (in)	Max (in)
A		4.470	4.670	A		0.176	0.184
A1		0.000	0.150	A1		0.000	0.006
B		1.120	1.420	B		0.044	0.056
b		0.710	0.910	b		0.028	0.036
b1		1.170	1.370	b1		0.046	0.054
c		0.310	0.530	c		0.012	0.021
c1		1.170	1.370	c1		0.046	0.054
D		10.01	10.31	D		0.394	0.406
E		8.700	9.400	E		0.343	0.370
e		2.540 (TYP)		e		0.100 (TYP)	
e1		4.980	5.180	e1		0.196	0.204
L		14.94	15.50	L		0.588	0.610
L1		4.950	5.450	L1		0.195	0.215
L2		2.340	2.740	L2		0.092	0.860
V		5.600 (REF)		V		0.220 (REF)	
Φ		0°	8°	Φ		0°	8°

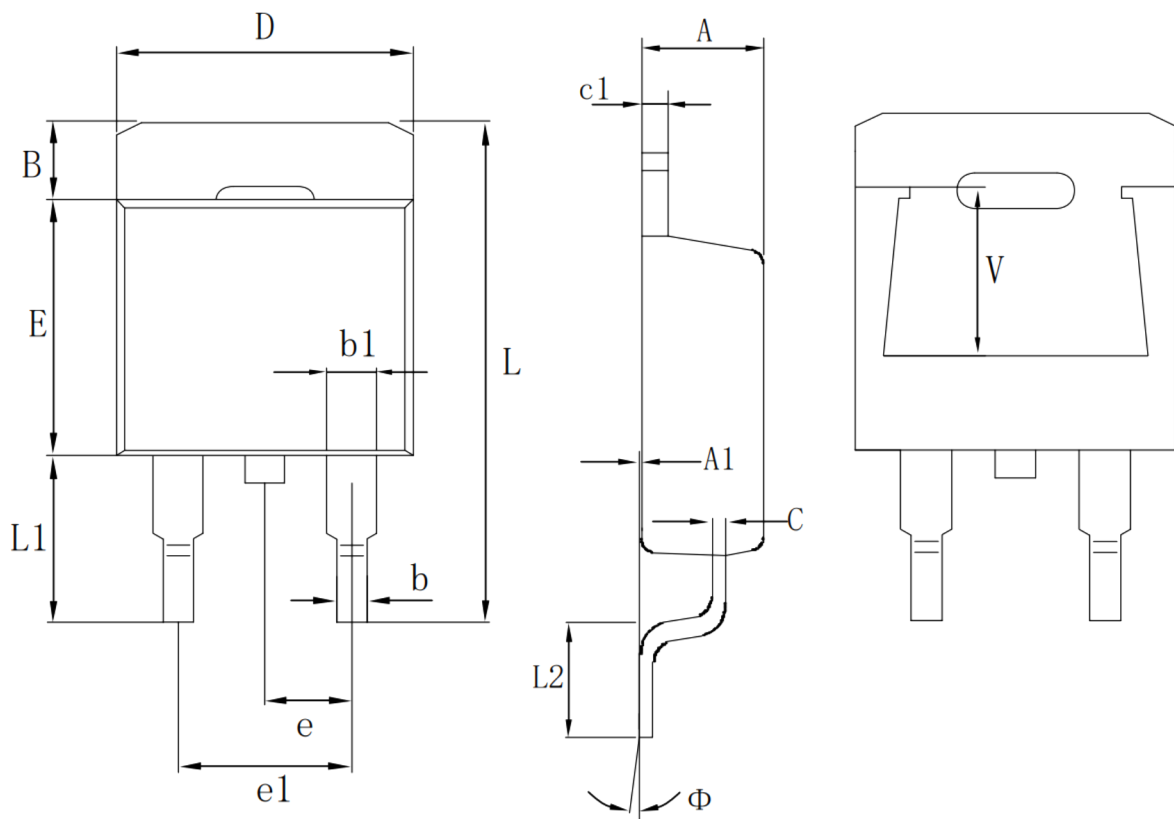

· T0-263-3L

Symbol	Size	Dimensions In Millimeters		Symbol	Size	Dimensions In Inches	
		Min (mm)	Max (mm)			Min (in)	Max (in)
A		4.470	4.670	A		0.176	0.184
A1		0.000	0.150	A1		0.000	0.006
B		1.120	1.420	B		0.044	0.056
b		0.710	0.910	b		0.028	0.036
b1		1.170	1.370	b1		0.046	0.054
c		0.310	0.530	c		0.012	0.021
c1		1.170	1.370	c1		0.046	0.054
D		10.01	10.31	D		0.394	0.406
E		8.700	9.400	E		0.343	0.370
e		2.540 (TYP)		e		0.100 (TYP)	
e1		4.980	5.180	e1		0.196	0.204
L		14.94	15.50	L		0.588	0.610
L1		4.950	5.450	L1		0.195	0.215
L2		2.340	2.740	L2		0.092	0.860
V		5.600 (REF)		V		0.220 (REF)	
Φ		0°	8°	Φ		0°	8°

