

-60V/-0.13A P-Channel Advanced Power MOSFET

Features

- Advanced trench process technology
- High Density Cell Design For Ultra Low On-Resistance
- ESD Rating: HBM 2000V

BVDSS	-60	V
ID	-0.13	A
RDSON@VGS=-10V	3	Ω
RDSON@VGS=-5V	5	Ω

Applications

- Power factor correction (PFC)
- Switched mode power supplies(SMPS)
- Uninterruptible Power Supply (UPS)

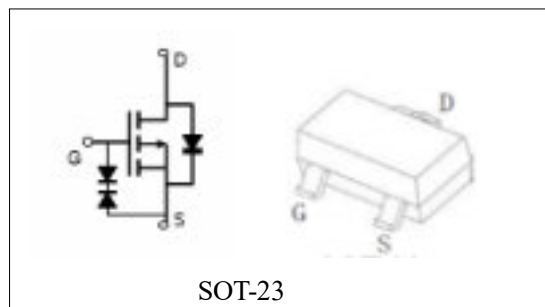

Order Information

Product	Package	Marking	Reel Size	Reel	Carton
BSS84	SOT-23	B84	7inch	3000PCS	180000PCS

Absolute Maximum Ratings

Symbol	Parameter	Rating	Unit
Common Ratings (TC=25°C Unless Otherwise Noted)			
$V_{(BR)DSS}$	Drain-Source Breakdown Voltage	-60	V
V_{GS}	Gate-Source Voltage	±20	V
T_J	Maximum Junction Temperature	150	°C
T_{STG}	Storage Temperature Range	-55 to 150	°C
I_S	Diode Continuous Forward Current	$T_A = 25^\circ\text{C}$ -0.13	A
Mounted on Large Heat Sink			
I_{DM}	Pulse Drain Current Tested (Silicon Limit) (Note1)	$T_A = 25^\circ\text{C}$ -0.52	A
I_D	Continuous Drain current	$T_A = 25^\circ\text{C}$ -0.13	A
P_D	Maximum Power Dissipation	$T_A = 25^\circ\text{C}$ 0.225	W
$R_{\theta JA}$	Thermal Resistance Junction-to-Ambient (Note2)	556	°C/W

-60V/-0.13A P-Channel Advanced Power MOSFET

Symbol	Parameter	Condition	Min.	Typ.	Max.	Unit
Static Electrical Characteristics @ T_J = 25°C (unless otherwise stated)						
V _{(BR)DSS}	Drain- Source Breakdown Voltage	VGS=0V ID=-250μA	-60	--	--	V
I _{DSS}	Zero Gate Voltage Drain current	VDS=-50V,VGS=0V	--	--	-1	μA
I _{GSS}	Gate-Body Leakage Current	VGS=±20V,VDS=0V	--	--	±10	μA
V _{GS(TH)}	Gate Threshold Voltage	VDS=VGS,ID=-250μA	-0.8	--	-2	V
R _{DS(ON)}	Drain-Source On-State Resistance (Note3)	VGS=-10V, ID=-0.5A	--	3	8	Ω
		VGS=-5V, ID=-0.2A	--	5	10	Ω
Dynamic Electrical Characteristics @ T_J = 25°C (unless otherwise stated) (Note4)						
C _{iss}	Input Capacitance	VDS=-5V, VGS=0V, F=1MHz	--	41.7	--	pF
C _{oss}	Output Capacitance		--	19.3	--	pF
C _{rss}	Reverse Transfer Capacitance		--	4	--	pF
Q _g	Total Gate Charge	VDS=-40V, ID=-0.1A, VGS=-4.5V	--	2.3	--	nC
Q _{gs}	Gate-Source Charge		--	2.4	--	nC
Q _{gd}	Gate-Drain Charge		--	0.7	--	nC
Switching Characteristics (Note4)						
t _{d(on)}	Turn-on Delay Time	VDS=-15V, ID=-0.25A, RL=6Ω, RG=50Ω, VGS=-15V	--	13.7	--	nS
t _r	Turn-on Rise Time		--	6.2	--	nS
t _{d(off)}	Turn-off Delay Time		--	15.9	--	nS
t _f	Turn-off Fall Time		--	2.8	--	nS
Source- Drain Diode Characteristics @ T_J = 25°C (unless otherwise stated)						
V _{SD}	Forward on voltage	IS=-0.5A,VGS=0V	--	--	-1.3	V

Note:

1. Repetitive Rating: Pulse width limited by maximum junction temperature.
2. Surface Mounted on FR4 Board, t ≤ 10 sec.
3. Pulse Test: pulse width ≤ 300 us, duty cycle ≤ 2%.
4. Guranteed by design, not subject to production testing.

-60V/-0.13A P-Channel Advanced Power MOSFET

Typical Characteristics

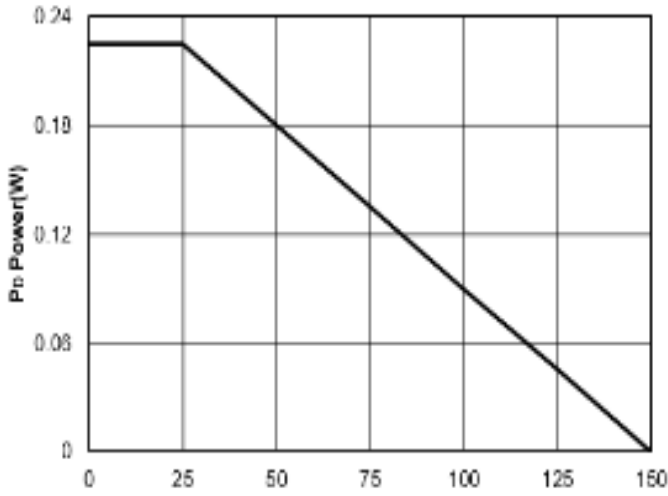

Figure1: T_J Junction Temperature (°C)

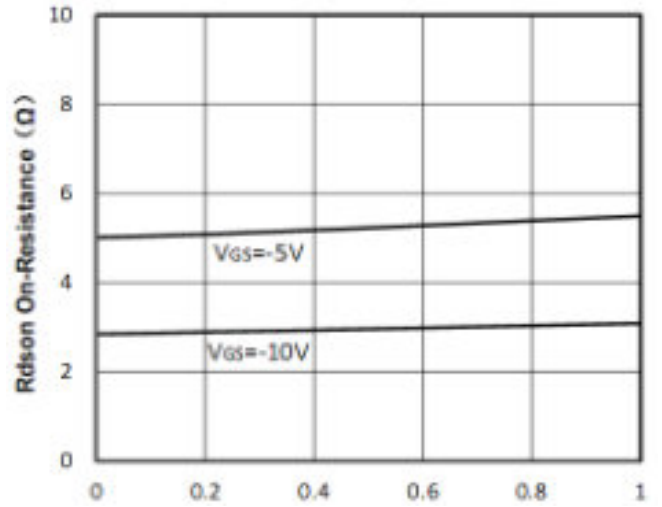

Figure2: -I_D Drain Current (A)

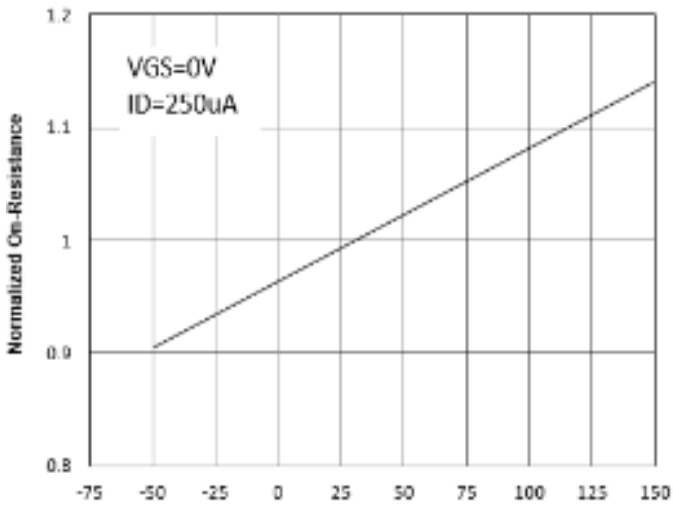

Figure3: T_J Junction Temperature (°C)

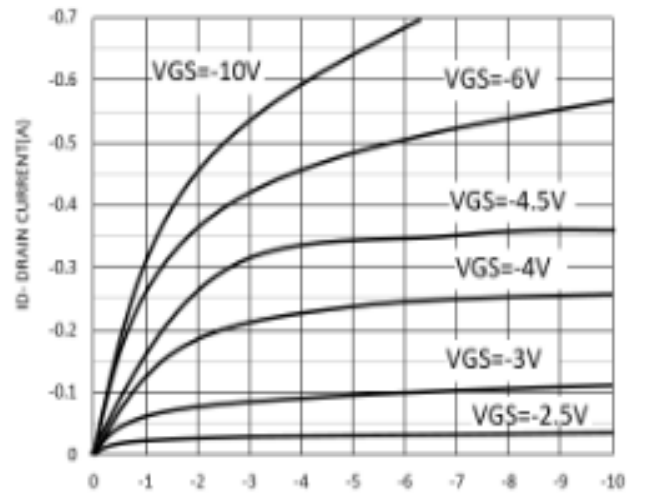

Figure4: -V_{DS} Drain-Source Voltage (V)

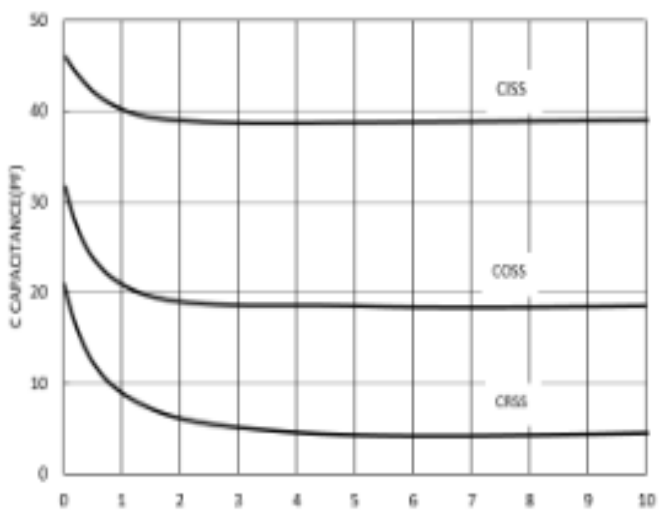

Figure5: -V_{DS} Drain-Source Voltage (V)

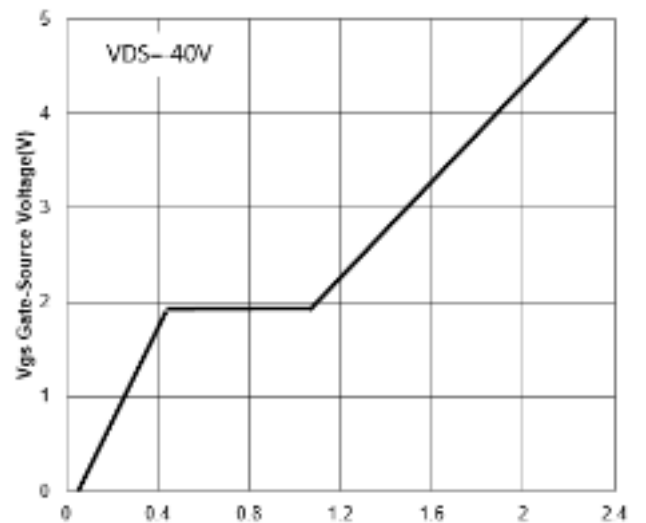

Figure6: Q_g Gate Charge (nC)

-60V/-0.13A P-Channel Advanced Power MOSFET

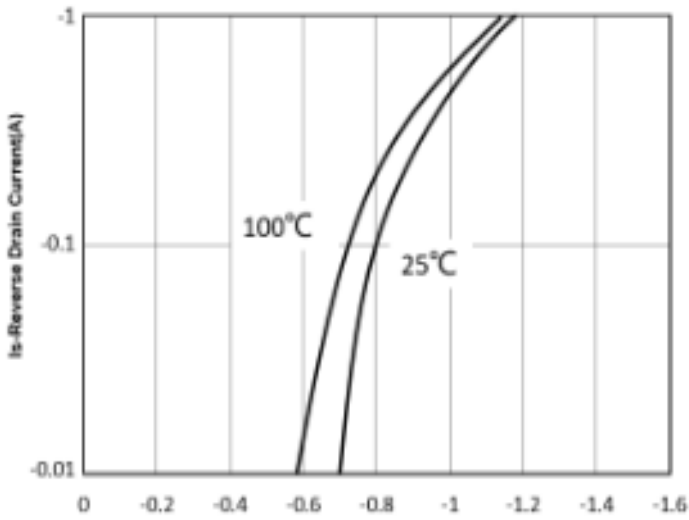

Figure7: -Vsd Source-Drain Voltage (V)

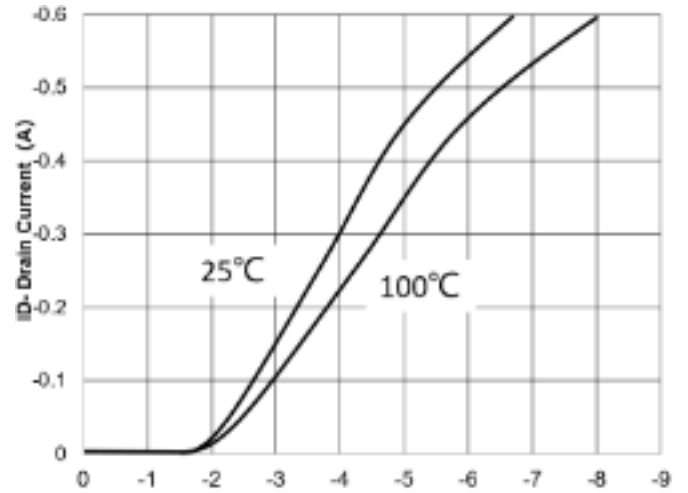

Figure8: -Vgs Gate-Source Voltage (V)

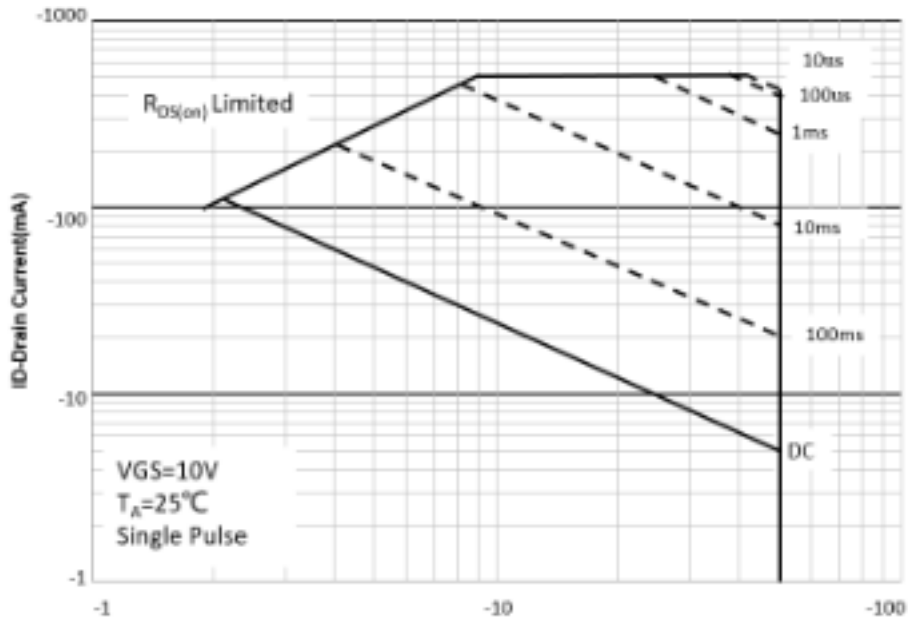

Figure9: -Vsd Drain -Source Voltage (V)

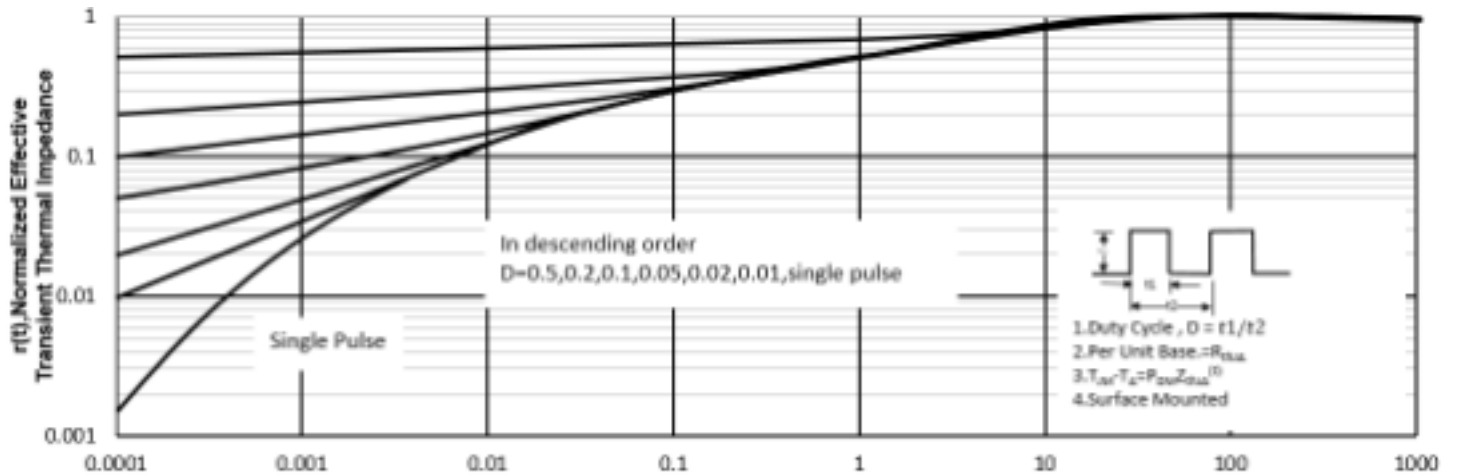

Figure10: Square Wave Pulse Duration (sec)

-60V/-0.13A P-Channel Advanced Power MOSFET

Test Circuit and Waveform:

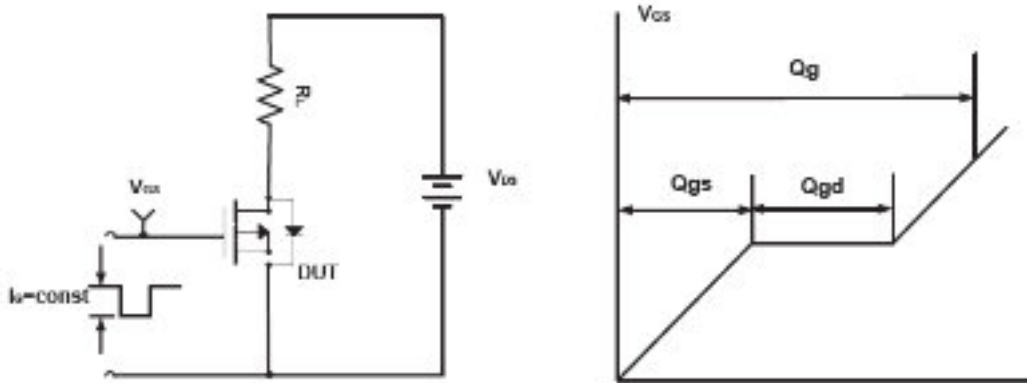

Figure A Gate Charge Test Circuit & Waveforms

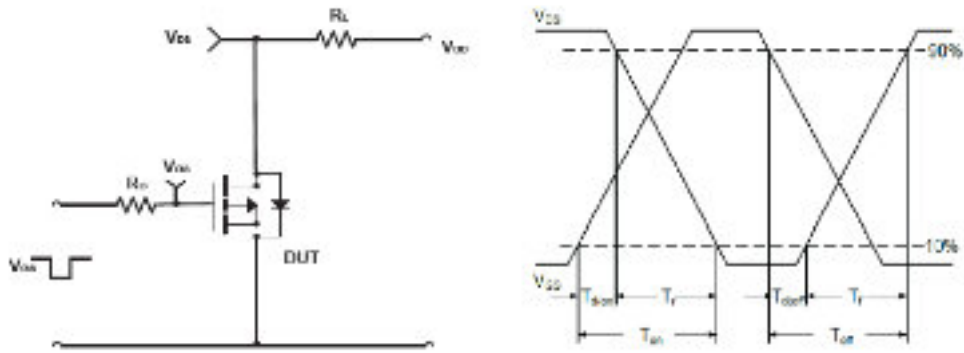

Figure B Switching Test Circuit & Waveforms

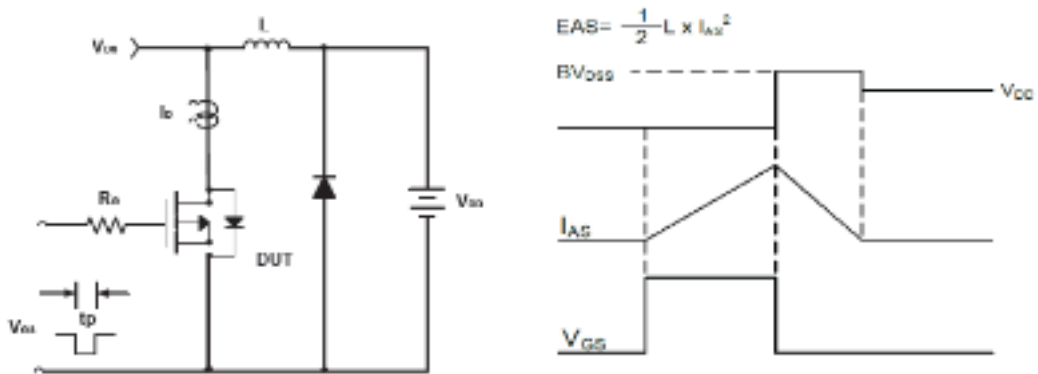
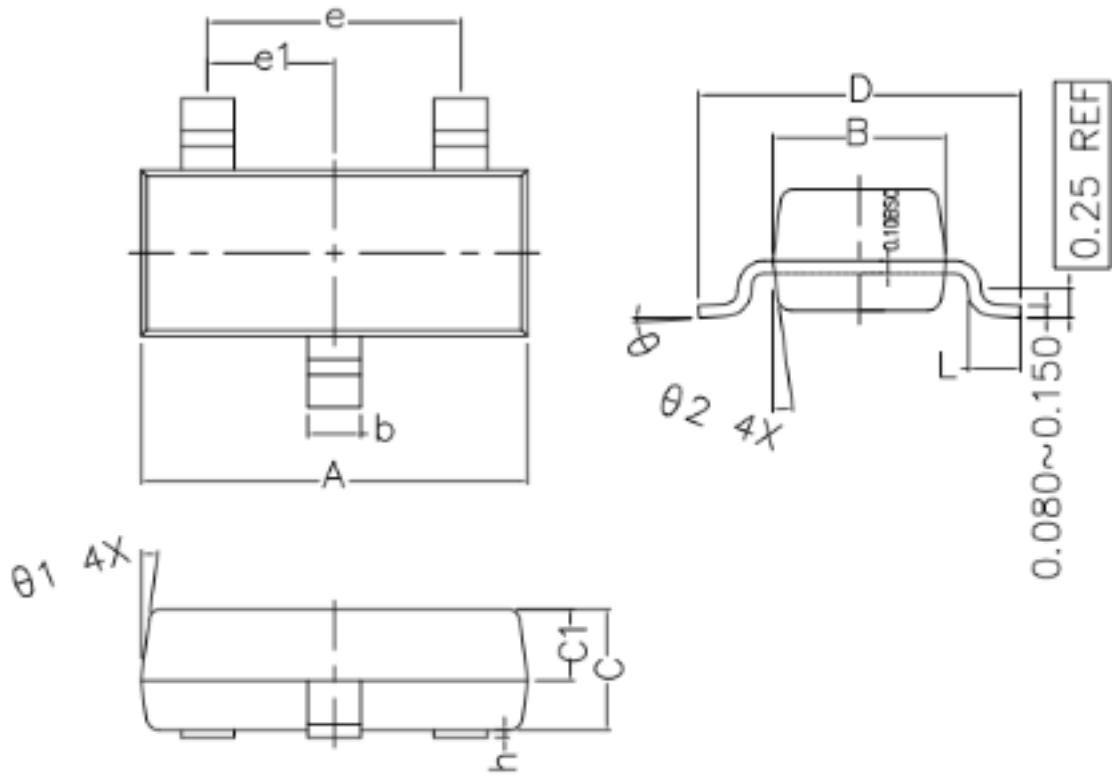

Figure C Unclamped Inductive Switching Circuit & Waveforms

-60V/-0.13A P-Channel Advanced Power MOSFET

SOT-23 Package Outline Dimensions (Units: mm)



COMMON DIMENSIONS (UNITS OF MEASURE IS mm)			
	MIN	NORMAL	MAX
A	2.800	2.900	3.000
B	1.200	1.300	1.400
C	0.900	1.000	1.100
C1	0.500	0.550	0.600
D	2.250	2.400	2.550
L	0.300	0.400	0.500
h	0.010	0.050	0.100
b	0.300	0.400	0.500
e	1.90 TYPE		
e1	0.95 TYPE		
theta ₁	7° TYPE		
theta ₂	7° TYPE		
theta	0° ~ 7°		