

20A 100V P-channel Enhancement Mode Power MOSFET

1 Description

These P-channel Enhanced VDMOSFETs, Used advanced trench technology and design, provide to excellent $R_{DS(on)}$ with low gate charge. Which accords with the RoHS standard.

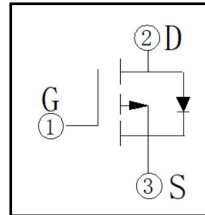

$V_{DS} = -100V$
$R_{DS(on)}(TYP) = 69m\Omega$
$I_D = -20A$

2 Features

- Fast Switching
- Low ON Resistance
- Low Gate Charge
- Low Reverse Transfer Capacitances
- 100% Single Pulse Avalanche Energy Test
- 100% ΔV_{DS} Test

3 Applications

- Suitable for Motor Drivers.
- Switching Regulators
- Converters and Relay Drivers
- Alertor



4 Electrical Characteristics

4.1 Absolute Maximum Rating ($T_c=25^\circ C$, unless otherwise noted)

Parameter	Symbol	Value		Units
		DH100P20/DH100P20I/DH100P20E/DH100P20B/DH100P20D	DH100P20F	
Drain-Source Voltage	V_{DS}	-100		V
Gate-Drain Voltage	V_{GS}	± 20		V
Drain Current(continuous)	I_D ($T=25^\circ C$) ($T=100^\circ C$)	-20		A
		-14		A
Drain Current(Pulsed) ^(Note 1)	I_{DM}	-80		A
Single Pulse Avalanche Energy ^(Note 5)	E_{AS}	264		mJ
Total Dissipation	$T_a=25^\circ C$	P_{tot}	2	W
	$T_c=25^\circ C$	P_{tot}	70	W
Junction Temperature	T_j	-55~150		$^\circ C$
storage Temperature	T_{stg}	-55~150		$^\circ C$
Maximum Temperature for soldering	T_L	300		$^\circ C$

4.2 Thermal Characteristics

Parameter	Symbol	Value		Units
		DH100P20/DH100P20I/DH100P20E/DH100P20B/DH100P20D	DH100P20F	
Thermal Resistance Junction to Case-sink	R_{thJC}	1.79	4.46	$^\circ C/W$
Thermal Resistance Junction to Ambient	R_{thJA}	62.5	62.5	$^\circ C/W$

4.3 Electrical Characteristics (T_c=25°C, unless otherwise noted)

Parameter	Symbol	Test Condition	Value			Units
			Min	Typ	Max	
Off Characteristics						
Drain-source Breakdown Voltage	BV _{DSS}	I _D =-250μA, V _{GS} =0V	-100	--	--	V
Drain-to-Source Leakage Current	I _{DSS}	V _{DS} =-100V, V _{GS} =0V, T _C =25°C	--	--	-1	μA
		V _{DS} =-80V, V _{GS} =0V, T _C =125°C	--	--	-100	μA
Gate-to-Source Forward Leakage	I _{GSSF}	V _{GS} =+20V	--	--	100	nA
Gate-to-Source Reverse Leakage	I _{GSSR}	V _{GS} =-20V	--	--	-100	nA
On Characteristics (Note 3)						
Gate threshold voltage	V _{GS(th)}	V _{DS} =V _{GS} , I _D =-250μA	-1	--	-3	V
Drain-source on-state Resistance	R _{DS(on)}	V _{GS} =-10V, I _D =-6A	--	69	95	mΩ
		V _{GS} =-4.5V, I _D =-3A	--	83	110	
Dynamic Characteristics (Note 4)						
Forward Transfer Conductance	g _{fs}	V _{DS} =-15V, I _D =-10A	5	--	--	S
Input Capacitance	C _{iss}	V _{GS} =0V, V _{DS} =-25V, f=1.0MHz	--	1300	--	pF
Output Capacitance	C _{oss}		--	400	--	
Reverse Transfer Capacitance	C _{rss}		--	240	--	
Switching Characteristics (note4)						
Turn-on Delay Time	t _{d(on)}	I _D =-10A, V _{DD} =-50V, V _{GS} =-10V, R _G =9.1Ω	--	16	--	nS
Turn-on Rise Time	t _r		--	73	--	
Turn-off Delay Time	t _{d(off)}		--	34	--	
Turn-off Fall Time	t _f		--	57	--	
Total Gate Charge	Q _g	I _D =-10A, V _{DD} =-50V, V _{GS} =-10V	--	61	--	nC
Gate-to-Source Charge	Q _{gs}		--	14	--	
Gate-to-Drain("Miller") Charge	Q _{gd}		--	29	--	
Drain-Source Diode Characteristics						
Diode Forward Voltage ⁽³⁾	V _{SD}	V _{GS} =0V, I _S =-20A	--	--	-1.5	V
Diode Forward Current ⁽²⁾	I _S		--	--	-20	A
Reverse Recovery Time	t _{rr}	T _J =25°C, I _F =-10A, di _F /dt=100A/μS, V _{GS} =0V	--	88.3	--	nS
Reverse Recovery Charge	Q _{rr}		--	66	--	nC

Notes:

- 1: Repetitive rating, pulse width limited by maximum junction temperature.
- 2: Surface mounted on FR4 Board, t_s≤10sec.
- 3: Pulse width ≤ 300μs, duty cycle ≤ 2%.
- 4: Guaranteed by design, not subject to production.
5. L=0.5mH, I_D=-32.5A, V_{DD}=-50V, V_{GATE}=-100V, Start T_J=25°C.

5 Typical characteristics diagrams

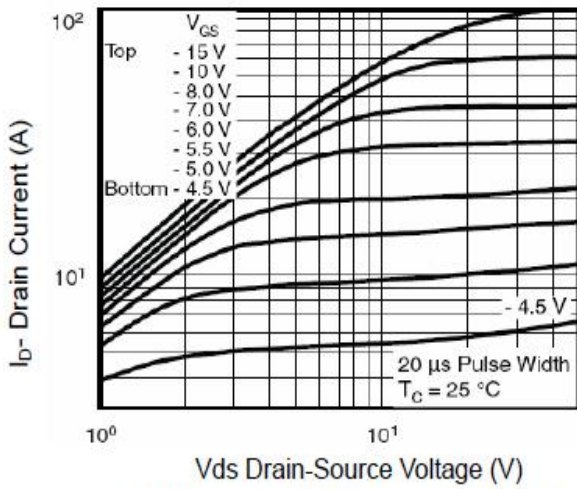

Figure 1 Output Characteristics

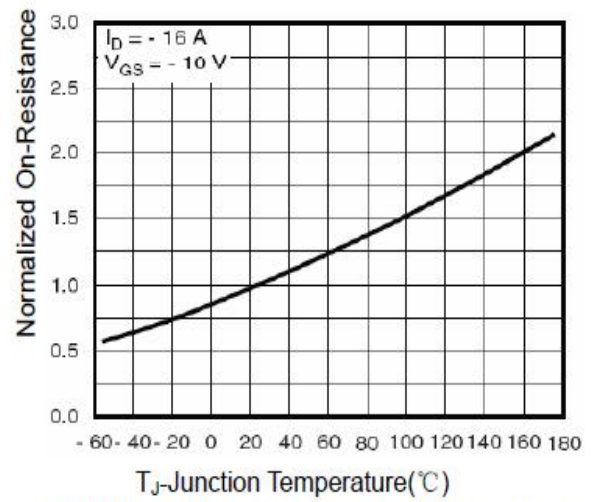

Figure 4 Rdson-Junction Temperature

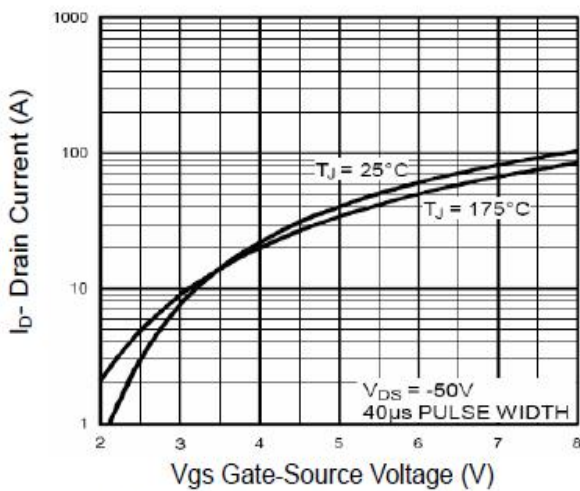

Figure 2 Transfer Characteristics

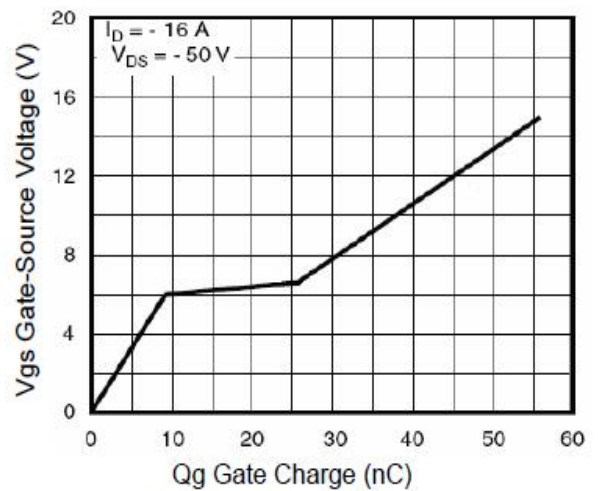

Figure 5 Gate Charge

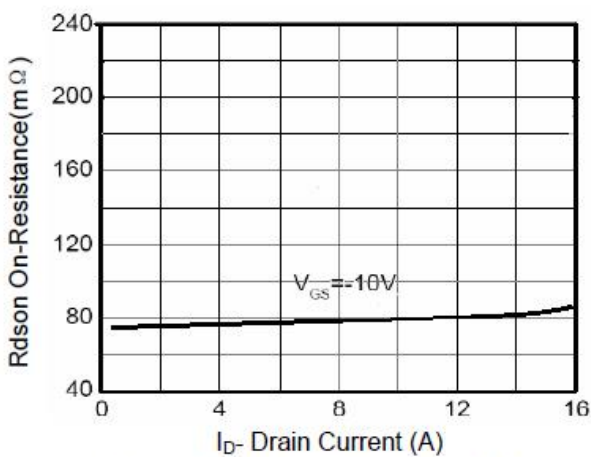

Figure 3 Rdson- Drain Current

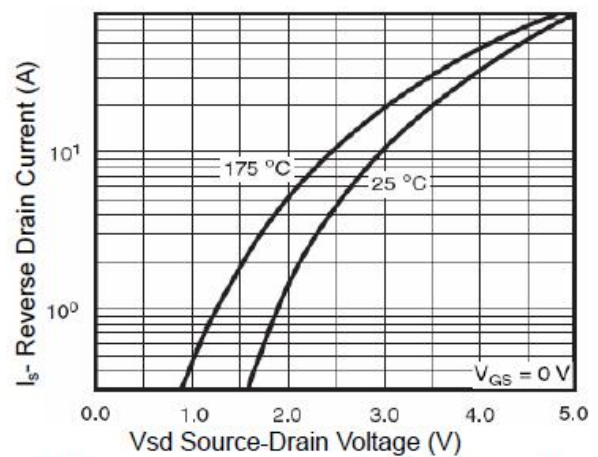

Figure 6 Source- Drain Diode Forward

5 Typical characteristics diagrams(continues)

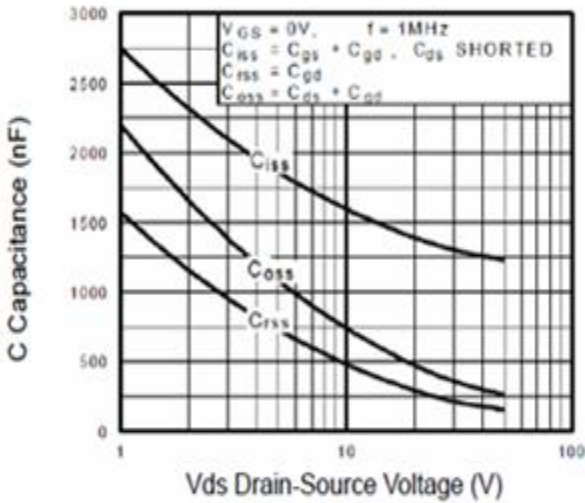

Figure 7 Capacitance vs Vds

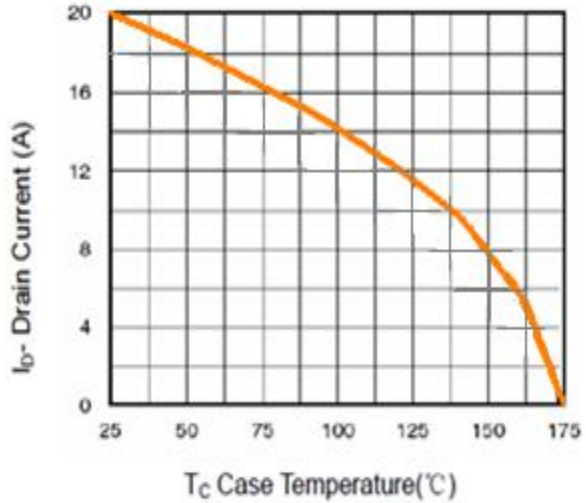

Figure 9 Drain Current vs Case Temperature

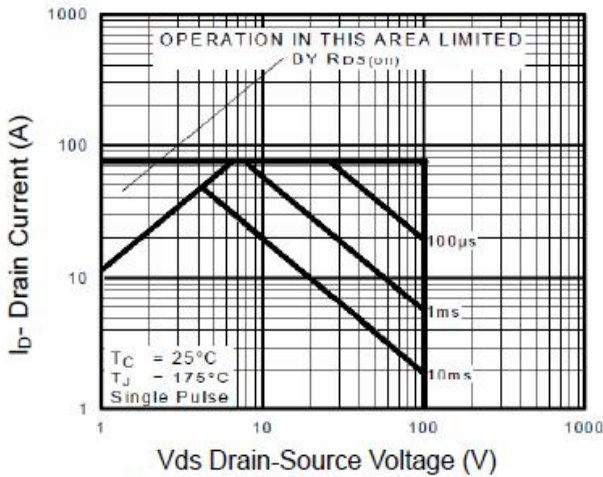

Figure 8 Safe Operation Area

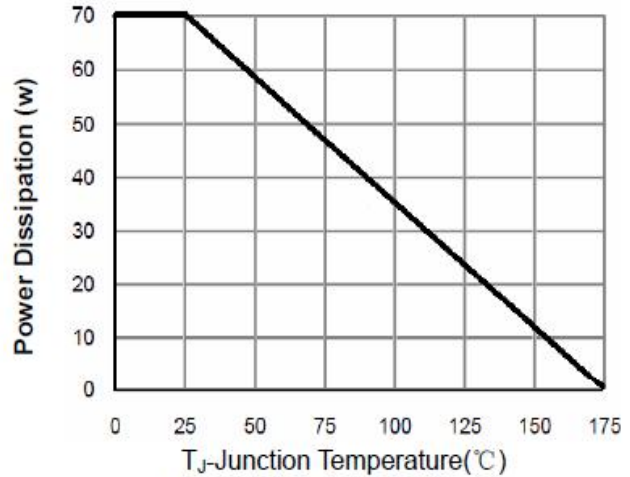

Figure 10 Power De-rating

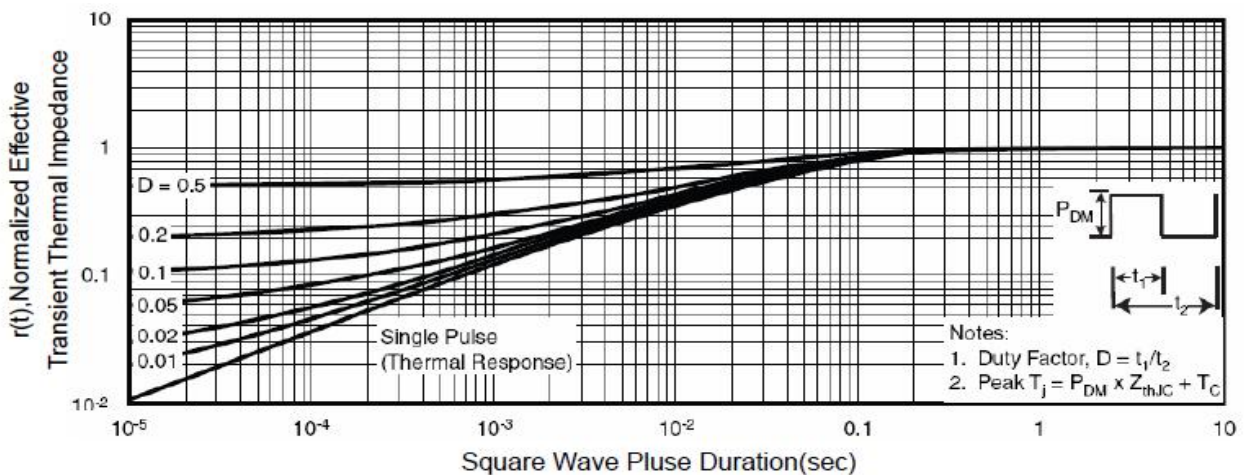
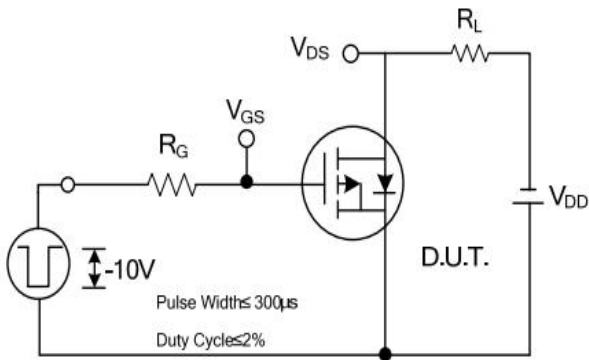
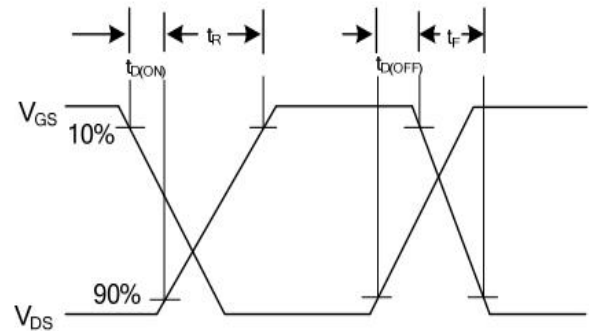

Figure 11 Normalized Maximum Transient Thermal Impedance

6 Typical Test Circuit and Waveform



Switching Test Circuit



Switching Waveforms

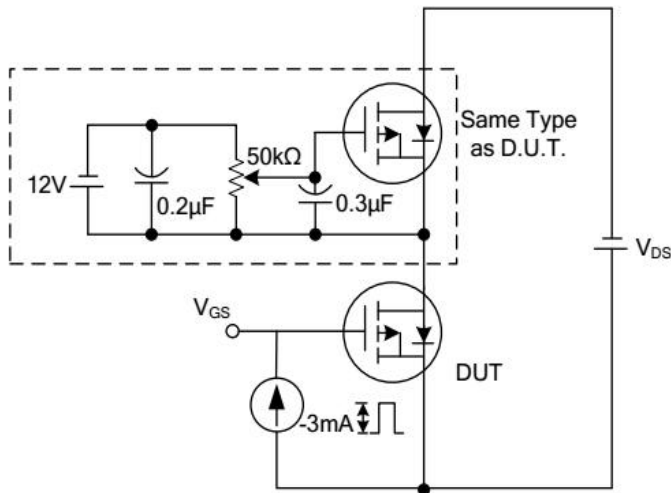

Gate Charge Test Circuit

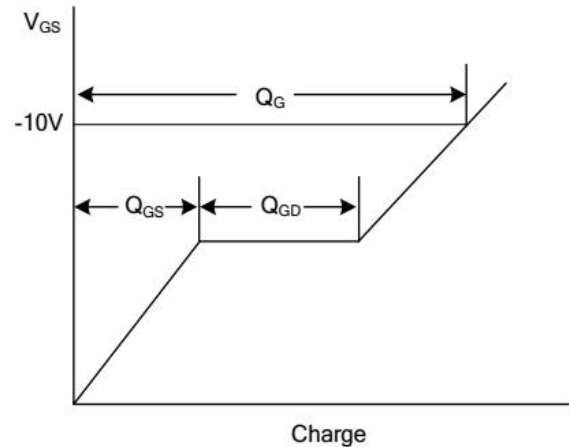

Gate Charge Waveform

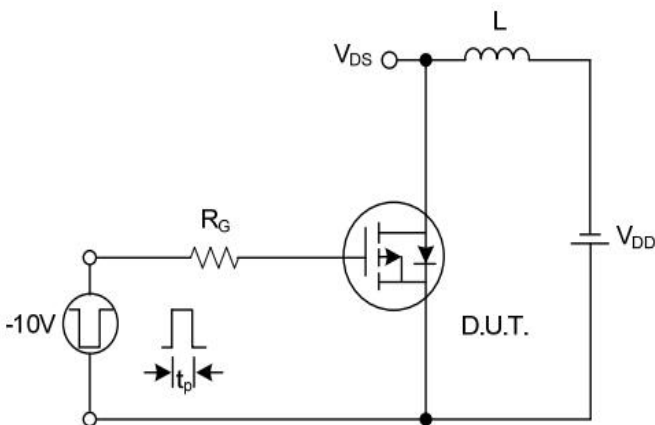

Unclamped Inductive Switching Test Circuit

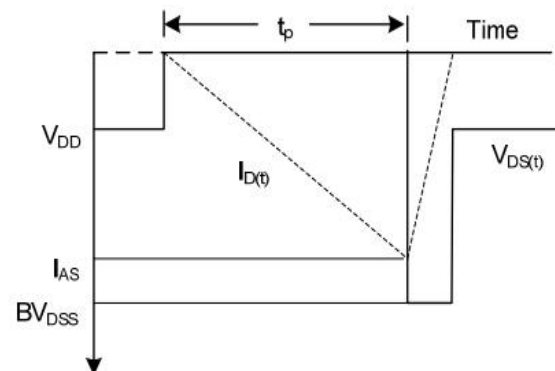

Unclamped Inductive Switching Waveforms

7 Product Names Rules

D H X X X N E X X F

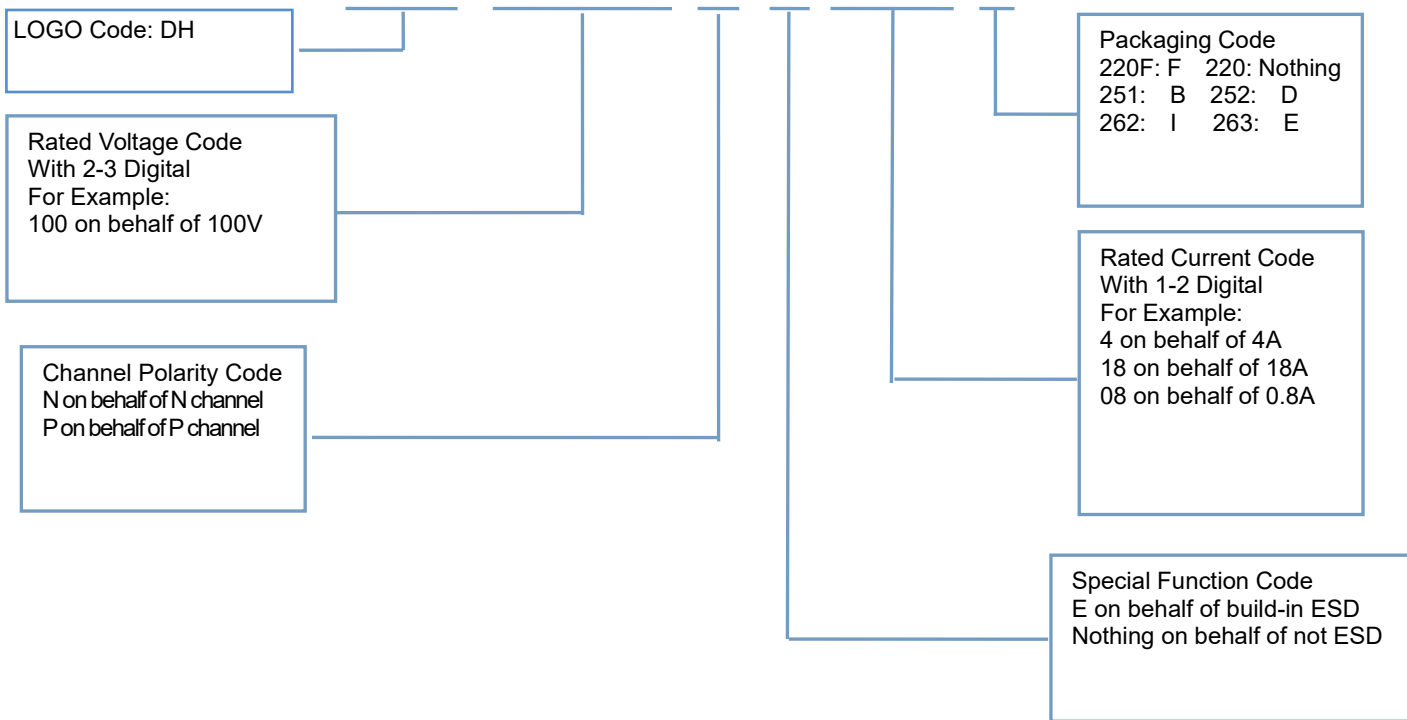

8 Product Specifications and Packaging Models

Product Model	Package Type	Mark Name	RoHS	Package	Quantity
DH100P20	TO-220C	DH100P20	Pb-free	Tube	1000/box
DH100P20F	TO-220F	DH100P20F	Pb-free	Tube	1000/box
DH100P20B	TO-251	DH100P20B	Pb-free	Tube	1000/box
DH100P20D	TO-252	DH100P20D	Pb-free	Tape & Reel	2500/box
DH100P20I	TO-262	DH100P20I	Pb-free	Tube	1000/box
DH100P20E	TO-263	DH100P20E	Pb-free	Tape & Reel	800/box

9 Dimensions

TO-251B PACKAGE OUTLINE DIMENSIONS

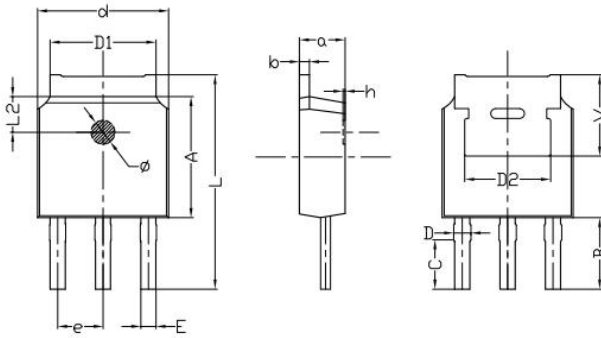

Symbol	Dimensions In Millimeters		Dimensions In Inches	
	min.	max.	min.	max.
a	2.20	2.40	0.087	0.0946
b	0.46	0.58	0.018	0.023
C	2.45	2.65	0.097	0.104
D	0.80	0.90	0.032	0.035
d	6.30	6.70	0.248	0.264
D1	5.00	5.50	0.197	0.217
D2	TYP 4.83		TYP 0.190	
A	5.80	6.20	0.228	0.244
e	2.19	2.39	0.086	0.094
L	10.40	11.00	0.4098	0.4334
B	3.50	3.70	0.1379	0.1458
L2	1.5	1.8	0.059	0.071
Φ	1.10	1.30	0.0433	0.0512
h	0.00	0.30	0.000	0.012
V	5.25	5.85	0.207	0.230
E	0.60	0.80	0.0236	0.0315

TO-252B PACKAGE OUTLINE DIMENSIONS

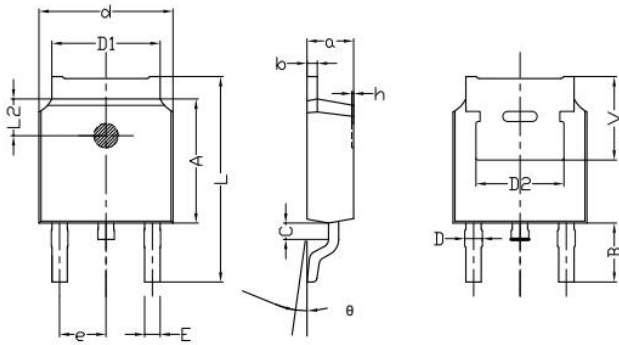

Symbol	Dimensions In Millimeters		Dimensions In Inches	
	min.	max.	min.	max.
a	2.20	2.40	0.087	0.095
b	0.46	0.58	0.018	0.023
c	0.70	0.90	0.028	0.035
D	0.80	1.00	0.032	0.039
d	6.30	6.70	0.248	0.264
D1	5.00	5.50	0.197	0.217
D2	TYP 4.83		TYP 0.190	
A	5.80	6.20	0.228	0.244
e	2.19	2.39	0.086	0.094
L	9.40	10.40	0.370	0.409
B	2.6	3.2	0.102	0.126
L2	1.5	1.8	0.059	0.071
θ	0	8	0	8
h	0	0.3	0	0.012
V	5.25	5.85	0.207	0.230
E	0.6	0.8	0.024	0.032

9 Dimensions(continues)

TO-220C PACKAGE OUTLINE DIMENSIONS

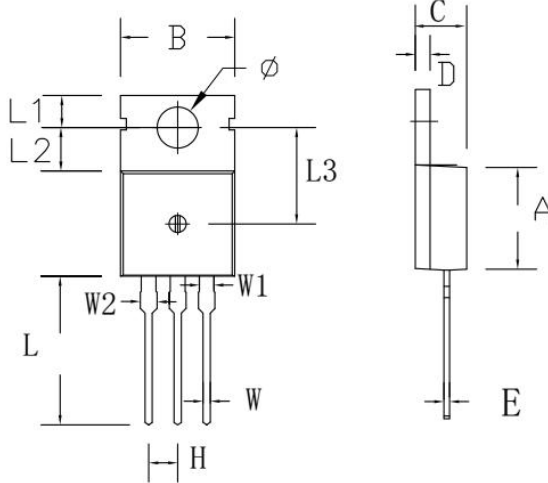

Symbol	Dimensions In Millimeters		Dimensions In Inches	
	min.	max.	min.	max.
A	8.80	9.30	0.346	0.366
B	9.70	10.30	0.382	0.406
C	4.25	4.75	0.167	0.187
D	1.20	1.45	0.047	0.057
E	0.40	0.60	0.016	0.024
H	2.54 TYP		0.100 TYP	
W	0.60	0.95	0.024	0.037
W1	1.05	1.45	0.041	0.057
W2	1.20	1.60	0.047	0.063
L	12.60	13.40	0.496	0.528
L1	2.45	2.95	0.096	0.116
L2	3.45	3.95	0.136	0.156
L3	8.15	8.65	0.321	0.341
Φ	3.50	3.90	0.138	0.154

TO-220F PACKAGE OUTLINE DIMENSIONS

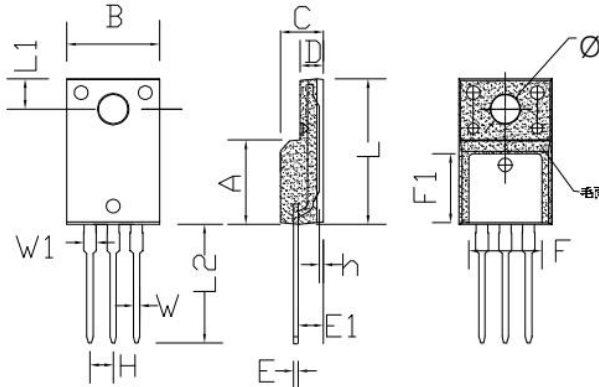

Symbol	Dimensions In Millimeters		Dimensions In Inches	
	min.	max.	min.	max.
A	8.80	9.30	0.346	0.366
B	10.00	10.50	0.394	0.413
C	4.30	4.90	0.169	0.193
D	2.30	2.70	0.091	0.106
L	15.55	16.15	0.612	0.636
h	0.40	0.60	0.016	0.024
L1	3.15	3.55	0.124	0.140
L2	12.65	13.35	0.498	0.526
W	0.70	0.90	0.028	0.035
W1	1.15	1.55	0.045	0.061
H	2.54 TYP		0.100 TYP	
E	0.48	0.53	0.019	0.021
Φ	2.90	3.40	0.114	0.134
E1	2.40	2.90	0.094	0.114
F	7.75	8.25	0.305	0.325
F1	7.35	7.85	0.289	0.309

9 Dimensions(continues)

TO-262 PACKAGE OUTLINE DIMENSIONS

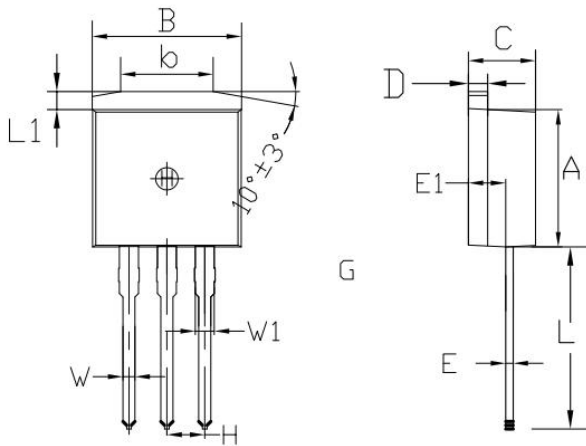

Symbol	Dimensions In Millimeters		Dimensions In Inches	
	min.	max.	min.	max.
A	8.80	9.30	0.346	0.366
B	9.70	10.30	0.382	0.406
C	4.25	4.75	0.167	0.187
D	1.20	1.45	0.047	0.057
E	0.40	0.60	0.016	0.024
L	12.25	13.75	0.482	0.541
L1	1.15	1.45	0.045	0.057
E1	2.4	2.6	0.0945	0.1024
W	0.80	0.82	0.0315	0.034
W1	1.20	1.30	0.047	0.051
H	2.54 TYP		0.200 TYP	
b	5.50	6.50	0.216	0.256

TO-263 PACKAGE OUTLINE DIMENSIONS

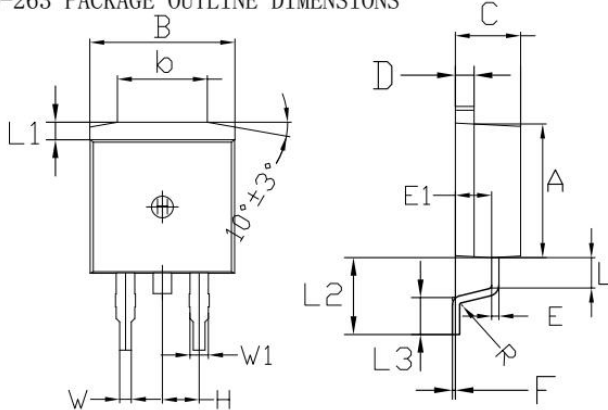

Symbol	Dimensions In Millimeters		Dimensions In Inches	
	min.	max.	min.	max.
A	8.80	9.30	0.346	0.366
B	9.70	10.30	0.382	0.406
C	4.25	4.75	0.167	0.187
D	1.20	1.45	0.047	0.057
E	0.40	0.60	0.016	0.024
L	1.90	2.30	0.075	0.091
L1	1.15	1.45	0.045	0.057
R	0.24	0.26	0.0095	0.0102
W	0.80	0.82	0.0315	0.0323
W1	1.20	1.30	0.047	0.051
H	2.54 TYP		0.200 TYP	
b	5.50	6.50	0.216	0.256
E1	2.4	2.6	0.0946	0.1024
L2	5.20	5.80	0.205	0.228
L3	2.20	3.20	0.087	0.126
F	0.03	0.23	0.0012	0.0091

10 Attentions

- Jiangsu Donghai Semiconductor Technology CO.,LTD. reserves the right to change the specification without prior notice! The customer should obtain the latest version of the information before making the order and verify that the information is complete and up to date.
- It is the responsibility of the purchaser for any failure or failure of any semiconductor product under certain conditions. It is the responsibility of the purchaser to comply with safety standards and to take safety measures in the system design and machine manufacturing of Donghai products in order to avoid potential risk of failure. Injury or property damage.
- Product promotion is endless, our company will be dedicated to provide customers with better products.

11 Appendix

Revision history:

Date	REV.	Description	Page
2017.03.14	1.0	Original	