

Dual N-Channel 17V (D-S) MOSFET

MAIN CHARACTERISTICS

<b>I<sub>D</sub></b>	6A
<b>V<sub>DSS</sub></b>	17V
<b>R<sub>DS(on)-typ(@V<sub>GS</sub>=4.5V)</sub></b>	≅ 29mΩ
<b>I<sub>D</sub></b>	5.2A
<b>V<sub>DSS</sub></b>	17V
<b>R<sub>DS(on)-typ(@V<sub>GS</sub>=2.5V)</sub></b>	≅ 42mΩ

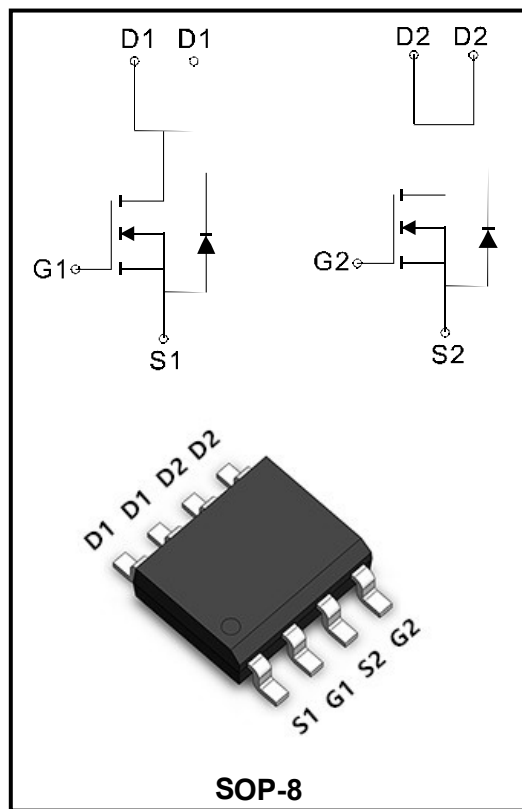

APPLICATIONS

- ◆ Power Management in Note book
- ◆ Portable Equipment
- ◆ Battery Powered System
- ◆ Load Switch
- ◆ DSC

Product Specification Classification

Part Number	Package	Marking	Pack
YFW9926S	SOP-8	YFW 9926S XXXXX	3000PCS/Tape

Maximum Ratings (Ta=25°C Unless Otherwise Noted)

Parameter		Symbol	10sec	SteadyState	Unit		
Drain-Source Voltage		<b>V<sub>DSS</sub></b>	17		V		
Gate-Source Voltage		<b>V<sub>GSS</sub></b>	±8		V		
Continuous Drain Current*	TA=25°C	<b>I<sub>D</sub></b>	6.6	5.2	A		
	TA=70°C		5.2	4.2			
Pulsed Drain Current		<b>I<sub>DM</sub></b>	30		A		
Maximum Power Dissipation*	TA=25°C	<b>P<sub>D</sub></b>	2.0	1.25	W		
	TA=70°C		1.2	0.8			
Operating Junction Temperature		<b>T<sub>J</sub></b>	-55 to 150		°C		
Thermal Resistance-Junction to Ambient*		<b>R<sub>θJA</sub></b>	Typ	45	Typ	80	°C/W
			Max	62.5	Max	100	

The \*The device mounted on 1in<sup>2</sup> FR4 board with 2 oz copper

Symbol	Parameter	Limit	Min	Typ	Max	Unit
<b>STATIC</b>						
<b>BV<sub>DSS</sub></b>	Drain-Source Breakdown Voltage	$V_{GS}=0, I_D=250/\mu A$	17			V
<b>V<sub>GS(th)</sub></b>	Gate Threshold Voltage	$V_{DS}=V_{GS}, I_D=250/\mu A$	0.4		1.2	V
<b>I<sub>GSS</sub></b>	Gate Body Leakage	$V_{DS}=0V, V_{GS}=\pm 8V$			$\pm 100$	nA
<b>I<sub>DSS</sub></b>	Zero Gate Voltage Drain Current	$V_{DS}=17V, V_{GS}=0V$			1	$\mu A$
<b>R<sub>DS(on)</sub></b>	Drain-Source On-Resistance	$V_{GS}=4.5V, I_D=6.0A$			29	m $\Omega$
		$V_{GS}=2.5V, I_D=5.2A$			42	
<b>V<sub>SD</sub></b>	Diode Forward Voltage	$I_S=1.7A, V_{GS}=0V$			1.2	V
<b>DYNAMIC</b>						
<b>Q<sub>g</sub></b>	Total Gate Charge	$V_{DS}=10V, V_{GS}=4.5V, I_D=6.0A$		8		nC
<b>Q<sub>gs</sub></b>	Gate-Source Charge			2.1		
<b>Q<sub>gd</sub></b>	Gate-Drain Charge			2.3		
<b>t<sub>d(on)</sub></b>	Turn-On Delay Time	$V_{DD}=10V, I_D=1.0A, V_{GEN}=4.5V, R_G=6\Omega$		14		ns
<b>t<sub>r</sub></b>	Turn-On Rise Time			17		
<b>t<sub>d(off)</sub></b>	Turn-Off Delay Time			43		
<b>t<sub>f</sub></b>	Turn-Off Fall Time			5		
<b>C<sub>iss</sub></b>	Input capacitance	$V_{DS}=15V, V_{GS}=0V, f=1.0MHz$		550		pF
<b>C<sub>oss</sub></b>	Output Capacitance			130		
<b>C<sub>rss</sub></b>	Reverse Transfer Capacitance			40		

Notes: a. Pulse test: pulse width  $\leq 300\mu s$ , duty cycle  $\leq 2\%$ , Guaranteed by design, not subject to production testing.

b. suchtech reserves the right to improve product design, functions and reliability without notice.

Typical Characteristics ( $T_J=25^\circ\text{C}$  Noted)

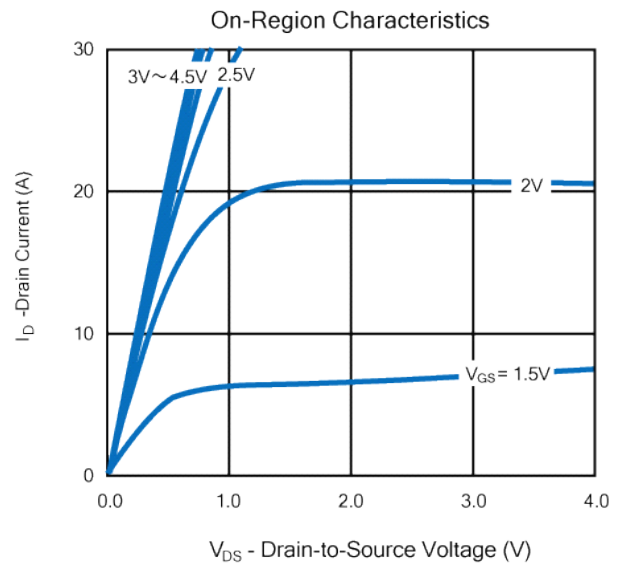
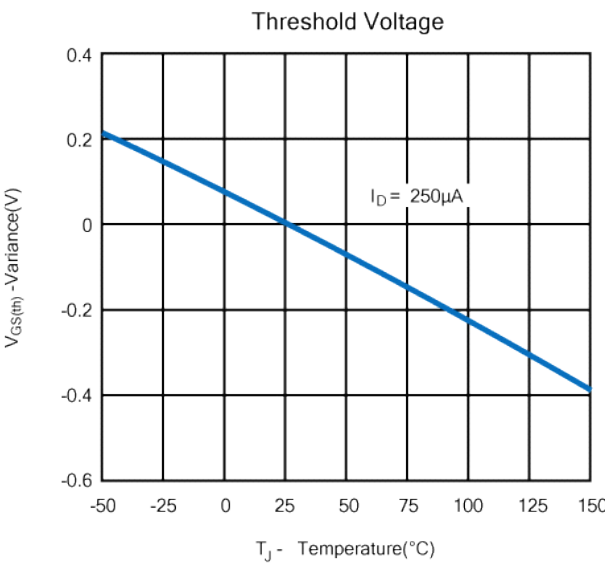
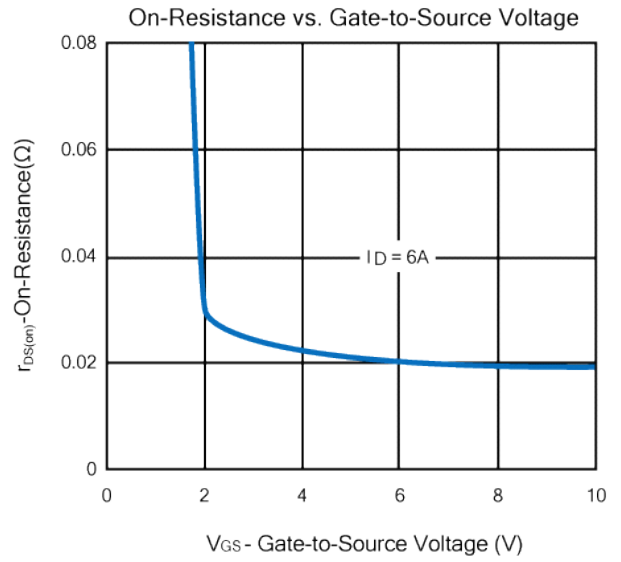
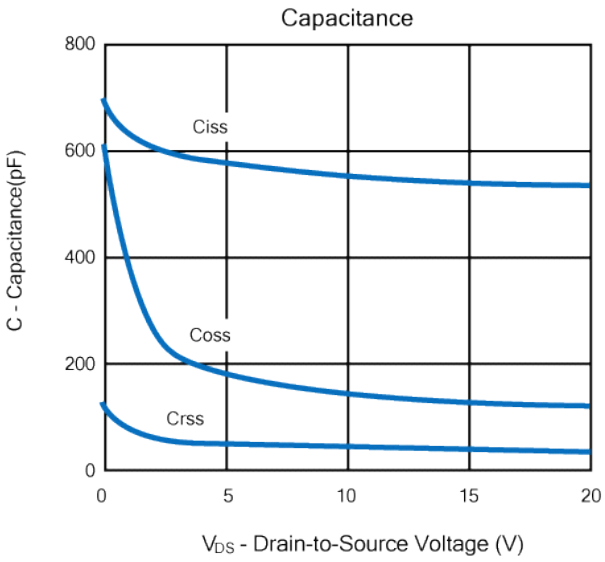
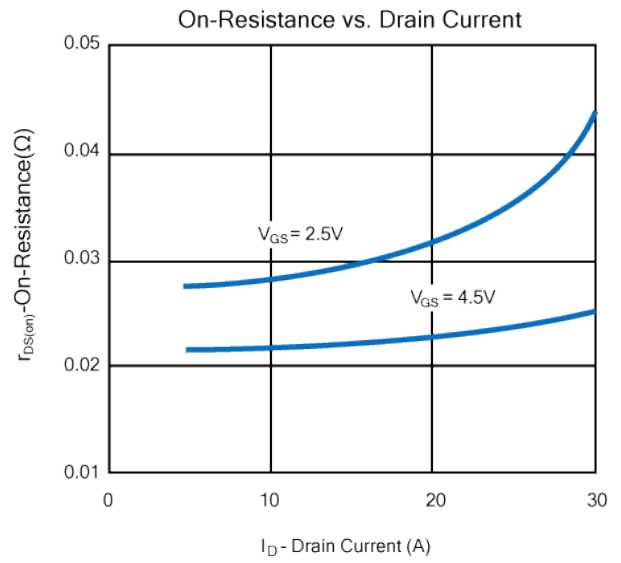
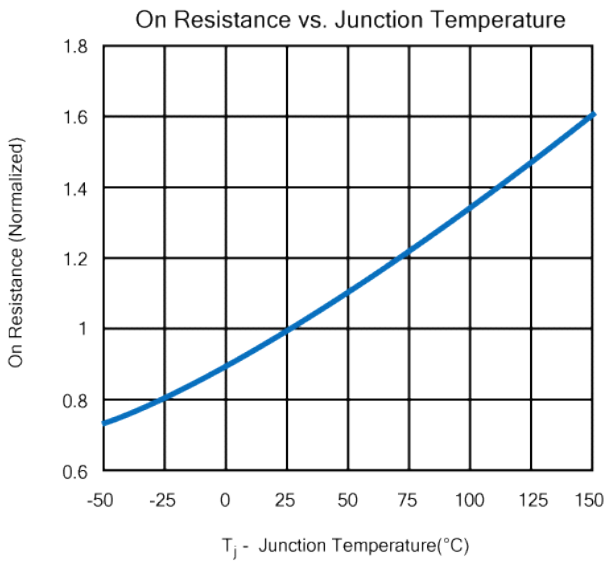

Typical Characteristics (T<sub>J</sub> = 25°C Noted)

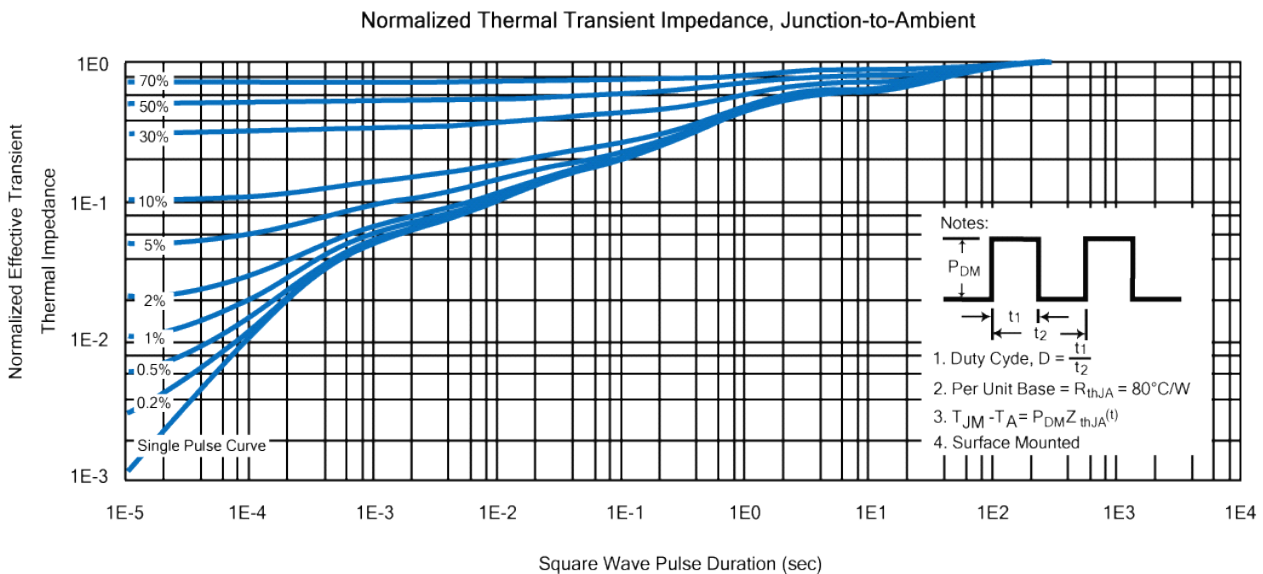
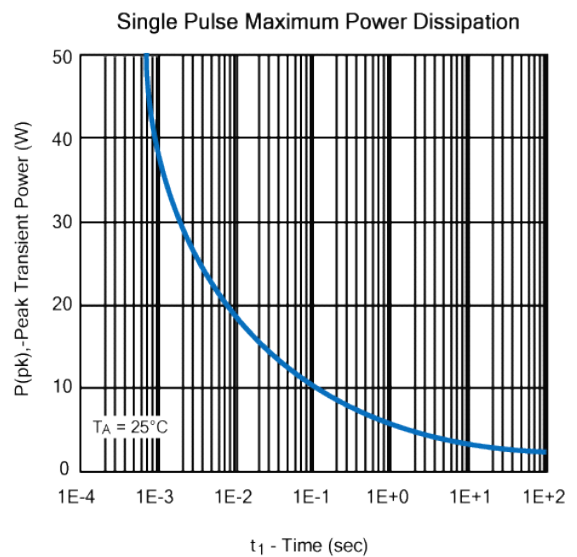
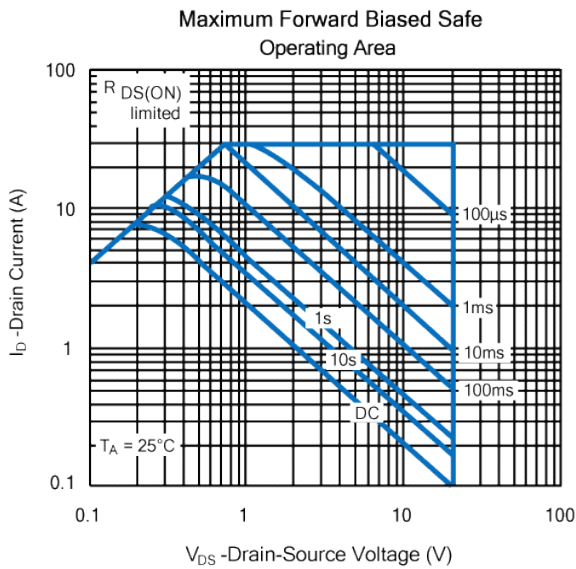
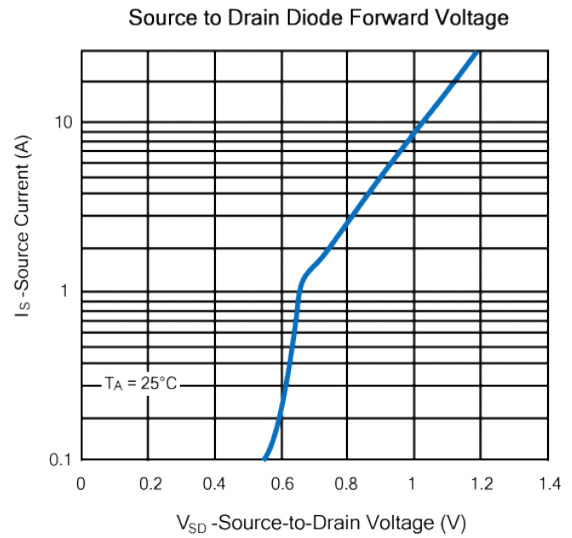
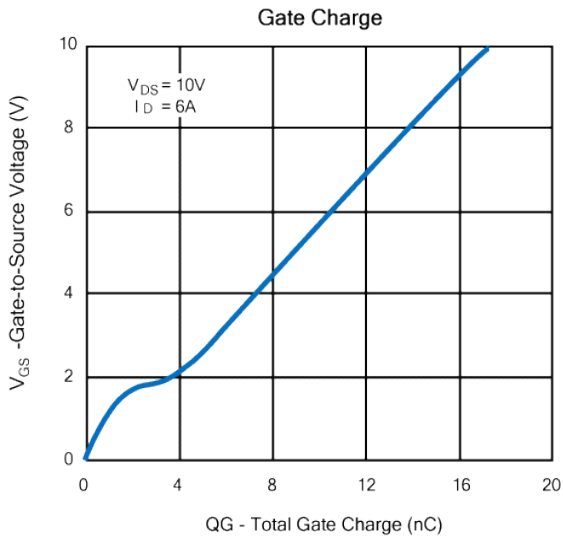

Package Outline SOP-8

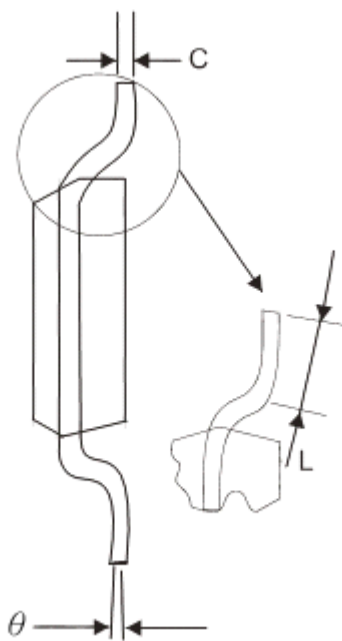
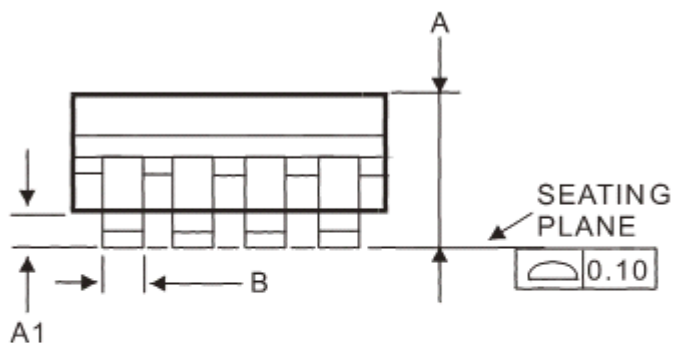
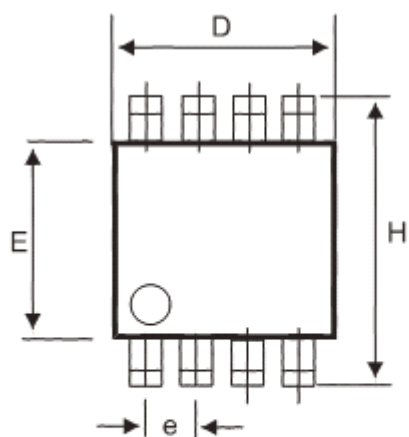

DIM	MILLIMETERS (mm)	
	MIN	MAX
A	1.35	1.75
A1	0.10	0.25
B	0.35	0.49
C	0.18	0.25
D	4.80	5.00
E	3.80	4.00
e	1.27 BSC	
H	5.80	6.20
L	0.40	1.25
θ	0°	7°

NNote: 1. Refer to JEDEC MS-012AA.

2. Dimension "D" does not include mold flash, protrusions or gate burrs . Mold flash, protrusions or gate burrs shall not exceed 0.15 mm per side.