

# TPIRF7403TRPBF

## N-Channel 30-V (D-S) MOSFET

### Product Summary

- $V_{DS}$  30 V
- $I_{DS}$  (@  $V_{GS}= 10V$ ) 9A
- $R_{DS(ON)}$  (@  $V_{GS}= 10V$ ) < 16m $\Omega$ (Typ)

### Application

- Reverse Battery protection
- Load switch
- Power management
- PWM Application

### Package and Pin Configuration

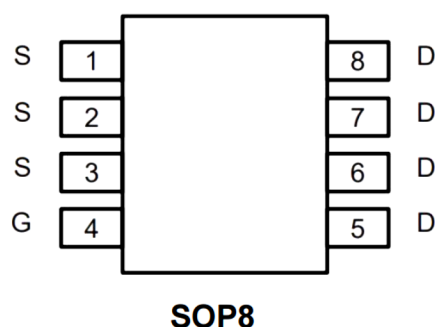

### Circuit diagram

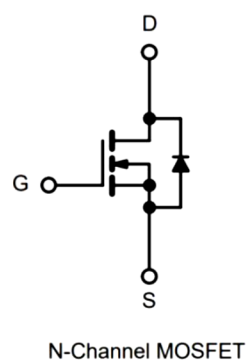

### Absolute Maximum Ratings (T<sub>A</sub>=25°C unless otherwise noted)

PARAMETER	SYMBOL	LIMIT	UNIT
Drain-Source Voltage	$V_{DS}$	30	V
Gate-Source Voltage	$V_{GS}$	±20	V
Continuous Drain Current	$I_D$	9	A
Pulsed Drain Current (note1)	$I_{DM}$	30	A
Maximum Power Dissipation	$P_D$	3	W
Operating Junction Temperature Range	$T_J$	-55 to +150	°C
Storage Temperature Range	$T_{stg}$	-55 to +150	°C

### Thermal Characteristic

PARAMETER		Symbol	Value	Unit
Thermal Resistance from Junction to Ambient(t≤10s)	PCB Mount (note2)	$R_{\theta JA}$	62.5	°C/W

notes 1. Repetitive Rating: Pulse width limited by maximum junction temperature.

2. When mounted on 1" square PCB (FR4 material).

# TPIRF7403TRPBF

## N-Channel 30-V (D-S) MOSFET

### Electrical Characteristics (T<sub>A</sub>=25 °C unless otherwise noted)

PARAMETER	CONDITIONS	SYMBOL	MIN	TYP	MAX	UNIT
<b>Static</b>						
Drain-Source Breakdown Voltage	V <sub>GS</sub> =0V, I <sub>D</sub> =250μA	BV <sub>DSS</sub>	30	--	--	V
Gate-Source Threshold Voltage	V <sub>DS</sub> =V <sub>GS</sub> , I <sub>D</sub> = 250μA	V <sub>GS(th)</sub>	1.0	--	2.5	V
Gate-Source Leakage	V <sub>DS</sub> =0V, V <sub>GS</sub> = ±20V	I <sub>GSS</sub>	--	--	±100	nA
Zero Gate Voltage Drain Current	V <sub>DS</sub> = 24V, V <sub>GS</sub> =0V	I <sub>DSS</sub>	--	--	1	μA
	V <sub>DS</sub> = 24V, T <sub>J</sub> =125°C		--	--	25	μA
Drain-Source On-State Resistance (Note 1)	V <sub>GS</sub> = 10V, I <sub>D</sub> =9A	R <sub>DS(on)</sub>	--	16	22	mΩ
	V <sub>GS</sub> = 4.5V, I <sub>D</sub> =7A		--	20	30	
Forward Transconductance (Note 2)	V <sub>DS</sub> = 10V, I <sub>D</sub> = 1A	g <sub>fs</sub>	--	3.8	--	S
<b>Dynamic</b> (Note 2)						
Total Gate Charge (Note 3)	V <sub>DS</sub> = 15V, I <sub>D</sub> =9A,	Q <sub>g</sub>	--	12.6	--	nC
Gate-Source Charge (Note 3)		Q <sub>gs</sub>	--	1.8	--	
Gate-Drain Charge (Note 3)		Q <sub>gd</sub>	--	2.7	--	
Input Capacitance	V <sub>DS</sub> =25V, V <sub>GS</sub> = 0V, F= 1.0MHz	C <sub>iss</sub>	--	492	--	pF
Output Capacitance		C <sub>oss</sub>	--	67	--	
Reverse Transfer Capacitance		C <sub>rss</sub>	--	49	--	
<b>Switching</b>						
Turn-On Delay Time (Note 3)	V <sub>DD</sub> = 15V, I <sub>D</sub> = 1A, V <sub>GS</sub> = 10V, R <sub>G</sub> = 6Ω	t <sub>d(on)</sub>	--	5.8	--	nS
Rise Time (Note 3)		t <sub>r</sub>	--	16.6	--	
Turn-Off Delay Time (Note 3)		t <sub>d(off)</sub>	--	31.2	--	
Fall Time (Note 3)		t <sub>f</sub>	--	7.6	--	
<b>Source-Drain Diode Ratings and Characteristics</b> (Note 2)						
Forward Voltage	V <sub>GS</sub> = 0V, I <sub>SD</sub> = 1A	V <sub>SD</sub>	--	0.8	1.2	V
Continuous Source Current	Integral reverse diode in the MOSFET	I <sub>S</sub>	--	--	9	A
Pulsed Current (Note 1)		I <sub>SM</sub>	--	--	30	A

Notes:

1. Pulse test; pulse width ≤ 300 μS, duty cycle ≤ 2%.
2. Guaranteed by design, not subject to production testing.
3. Independent of operating temperature

# TPIRF7403TRPBF

## N-Channel 30-V (D-S) MOSFET

### TYPICAL CHARACTERISTICS (25 °C, unless otherwise noted)

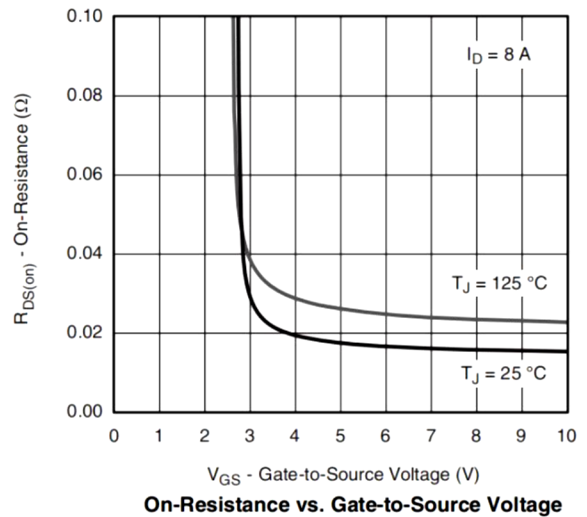
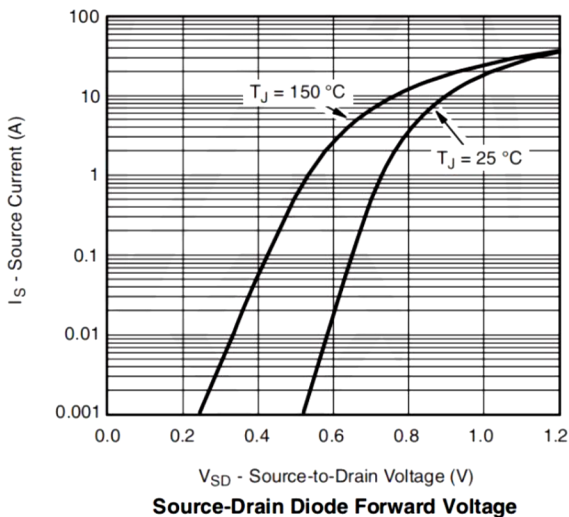
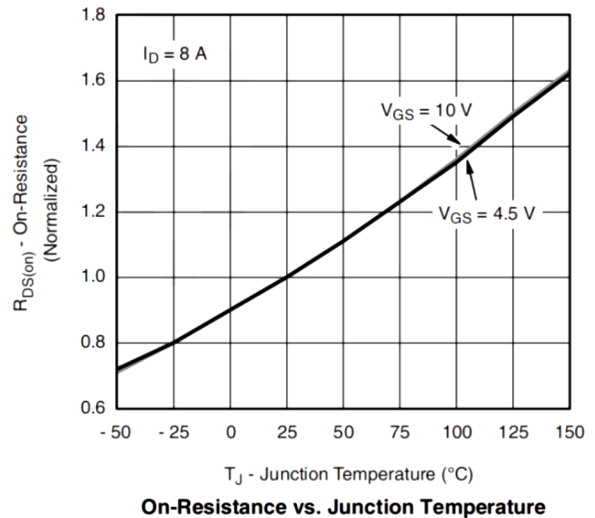
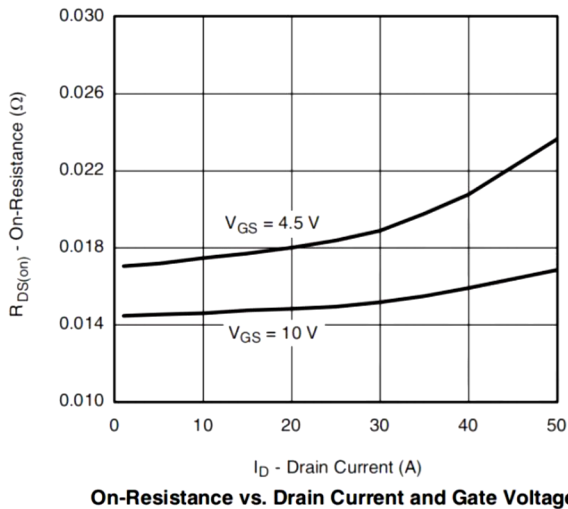
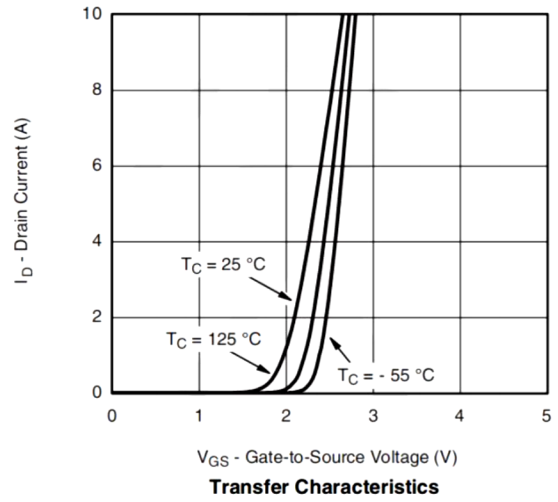
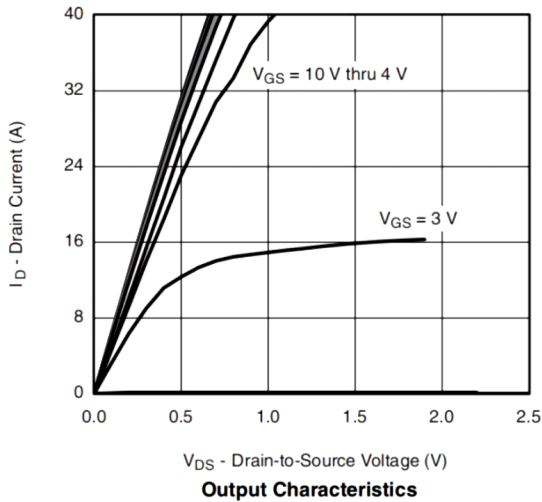

# TPIRF7403TRPBF

## N-Channel 30-V (D-S) MOSFET

### Package Information SOP8

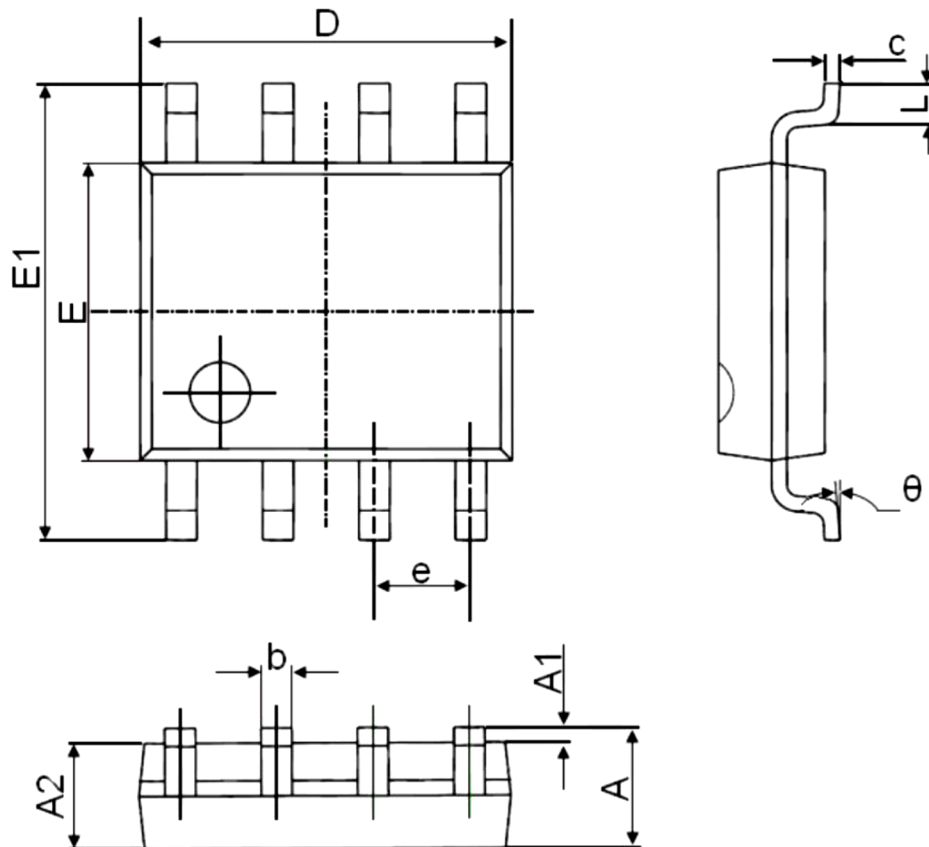

Symbol	Dimensions In Millimeters		Dimensions In Inches	
	Min.	Max.	Min.	Max.
A	1.350	1.750	0.053	0.069
A1	0.100	0.250	0.004	0.010
A2	1.350	1.550	0.053	0.061
b	0.330	0.510	0.013	0.020
c	0.170	0.250	0.006	0.010
D	4.700	5.100	0.185	0.200
E	3.800	4.000	0.150	0.157
E1	5.800	6.200	0.228	0.244
e	1.270(BSC)		0.050(BSC)	
L	0.400	1.270	0.016	0.050
θ	0°	8°	0°	8°