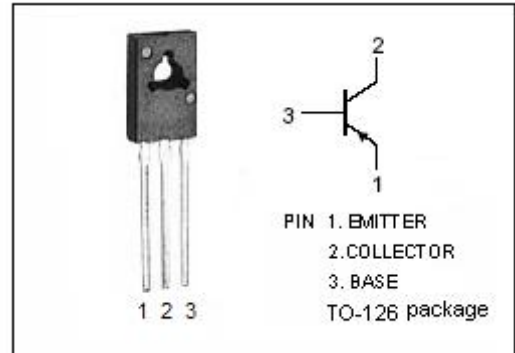

DESCRIPTION

- Collector–Emitter Sustaining Voltage–
: $V_{CEO(SUS)} = -300\text{ V}(\text{Min})$
- DC Current Gain–
: $h_{FE} = -100(\text{Min}) @ I_C = -50\text{ mA}$
- Low Collector Saturation Voltage–
: $V_{CE(sat)} = -1.0\text{ V}(\text{Max.}) @ I_C = -50\text{ mA}$
- Complement to the NPN MJE340

APPLICATIONS

- Designed for high voltage and general purpose applications.

ABSOLUTE MAXIMUM RATINGS ($T_a = 25^\circ\text{C}$)

SYMBOL	PARAMETER	VALUE	UNIT
V_{CBO}	Collector-Base Voltage	-300	V
V_{CEO}	Collector-Emitter Voltage	-300	V
V_{EBO}	Emitter-Base Voltage	-3	V
I_C	Collector Current-Continuous	-0.5	A
P_C	Collector Power Dissipation $T_C = 25^\circ\text{C}$	20	W
T_j	Junction Temperature	150	$^\circ\text{C}$
T_{stg}	Storage Temperature Range	-65~150	$^\circ\text{C}$

THERMAL CHARACTERISTICS

SYMBOL	PARAMETER	MAX	UNIT
$R_{th\ j-c}$	Thermal Resistance, Junction to Case	6.25	$^\circ\text{C/W}$

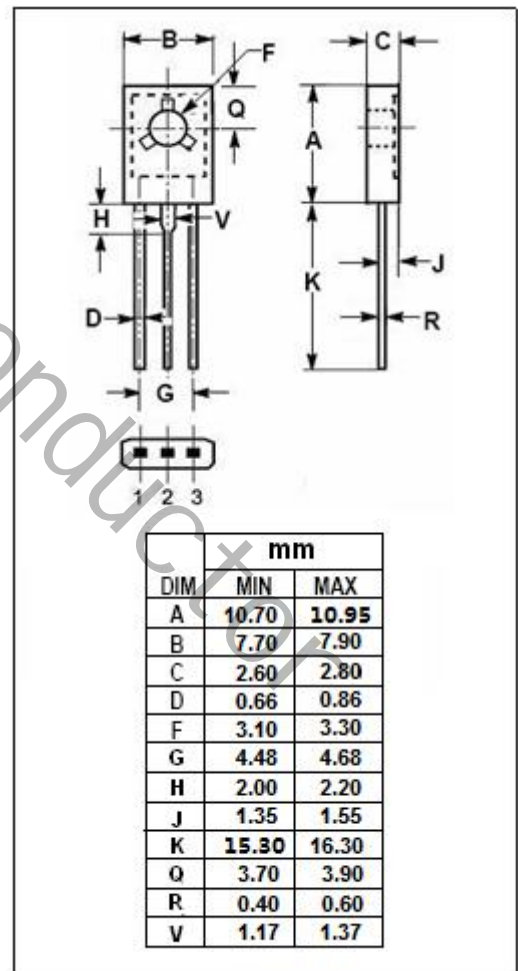

ELECTRICAL CHARACTERISTICS
 $T_c = 25^\circ\text{C}$ unless otherwise specified

SYMBOL	PARAMETER	CONDITIONS	MIN	MAX	UNIT
$V_{CE(SUS)}$	Collector-Emitter Sustaining Voltage	$I_C = -1.0\text{mA}; I_B = 0$	-300		V
$V_{(BR)CBO}$	Collector-Base Breakdown Voltage	$I_C = -1.0\text{mA}; I_E = 0$	-300		V
$V_{(BR)EBO}$	Emitter-Base Breakdown Voltage	$I_E = -1.0\text{mA}; I_C = 0$	-3		V
$V_{CE(sat)}$	Collector-Emitter Saturation Voltage	$I_C = -50\text{mA}; I_B = -5\text{mA}$		-1.0	V
I_{CBO}	Collector Cutoff Current	$V_{CB} = -300\text{V}; I_E = 0$		-0.1	mA
I_{EBO}	Emitter Cutoff Current	$V_{EB} = -3\text{V}; I_C = 0$		-0.1	mA
h_{FE}	DC Current Gain	$I_C = -50\text{mA}; V_{CE} = -10\text{V}$	30	240	