

■ PRODUCT CHARACTERISTICS

VDSS	-30V
$R_{DS(on)}$ Typ($V_{GS}@=-4.5$ V)	44m Ω
$R_{DS(on)}$ Typ($V_{GS}@=-2.5$ V)	55m Ω
ID	-4.2

■ APPLICATIONS

Load/Power Switching
Interfacing Switching

■ FEATURES

Advanced trench process technology
High Density Cell Design For Ultra Low On-Resistance

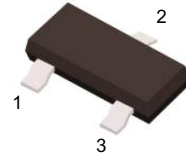
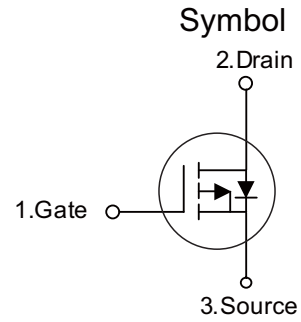

■ ORDER INFORMATION

Order codes		Package	Packing
Halogen-Free	Halogen		
N/A	MOT3401AA3	SOT-23A-3L	3000pieces/Real

■ ABSOLUTE MAXIMUM RATINGS ($T_c = 25^\circ\text{C}$ unless otherwise noted)

PARAMETER	SYMBOL	RATINGS	UNIT	
Drain-Source Voltage	V_{DS}	-30	V	
Gate-Source Voltage	V_{GS}	± 12	V	
Continuous Drain Current	I_D	-4.2	A	
Pulsed Drain Current	I_{DM}	-30	A	
Maximum Power Dissipation	P_D	$T_A = 25^\circ\text{C}$	1.4	W
		$T_A = 75^\circ\text{C}$	1	W
Operating Junction and Storage Temperature Range	T_J, T_{stg}	-55 to 150	$^\circ\text{C}$	
Junction-to-Ambient Thermal Resistance (PCB mounted)	$R_{\theta JA}$	125	$^\circ\text{C/W}$	

■ ELECTRICAL CHARACTERISTICS (T_C=25°C, unless otherwise specified)

Parameter	Symbol	Test condition	Min.	Typ.	Max.	Unit
Static						
Drain-Source Breakdown Voltage	BV _{DSS}	V _{GS} = 0V, I _D = -250uA	-30	-	-	V
Drain-Source On-State Resistance	R _{DS(on)}	V _{GS} = -10V, I _D = -4A	-	40	60	mΩ
		V _{GS} = -4.5V, I _D = -3A	-	44	65	mΩ
		V _{GS} = -2.5V, I _D = -3A	-	55	75	mΩ
		V _{GS} = -2.5V, I _D = -3A	-	55	75	mΩ
Gate Threshold Voltage	V _{GS(th)}	V _{DS} = V _{GS} , I _D = -250uA	-0.7	-1	-1.3	V
Zero Gate Voltage Drain Current	I _{DSS}	V _{DS} = -24V, V _{GS} = 0V	-	-	-1	uA
Gate Body Leakage	I _{GSS}	V _{GS} = ± 12V, V _{DS} = 0V	-	-	± 100	nA
Forward Transconductance	g _{fs}	V _{DS} = -5V, I _D = -5A	7	11		S
Dynamic						
Total Gate Charge	Q _g	V _{DS} = 20V, I _D = 5.7A V _{GS} = 10V	-	9.4	-	nC
Gate-Source Charge	Q _{gs}		-	2	-	nC
Gate-Drain Charge	Q _{gd}		-	3	-	nC
Turn-On Delay Time	t _{d(on)}	V _{DD} = 20V, RL=20Ω I _D = 1A, V _{GEN} = 10V R _G = 6Ω	-	6.3	-	ns
Turn-On Rise Time	t _r		-	3.2	-	ns
Turn-Off Delay Time	t _{d(off)}		-	38.2	-	ns
Turn-Off Fall Time	t _f		-	12	-	ns
Input Capacitance	C _{iss}	V _{DS} = 8V, V _{GS} = 0V f = 1.0 MHz	-	954	-	pF
Output Capacitance	C _{oss}		-	115	-	pF
Reverse Transfer Capacitance	C _{rss}		-	77	-	pF
Source-drain diode						
Max. Diode Forward Current	I _S		-	-	-2.2	A
Diode Forward Voltage	V _{SD}	I _S = 2.9A, V _{GS} = 0V	-	-	-1.0	V

Note: Pulse test: pulse width ≤ 300us, duty cycle ≤ 2%

■ TYPICAL CHARACTERISTICS

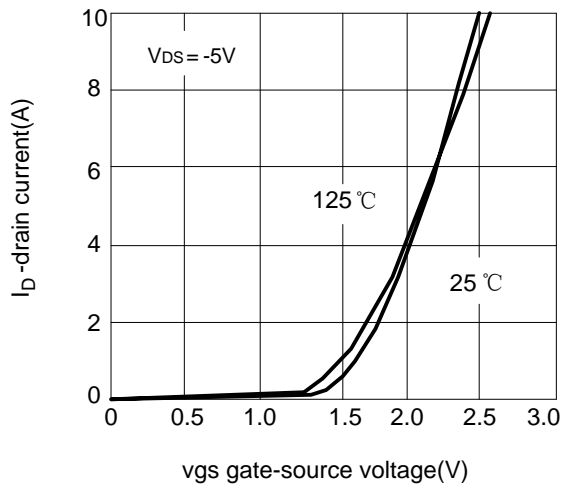

Fig.1 transfer characteristics

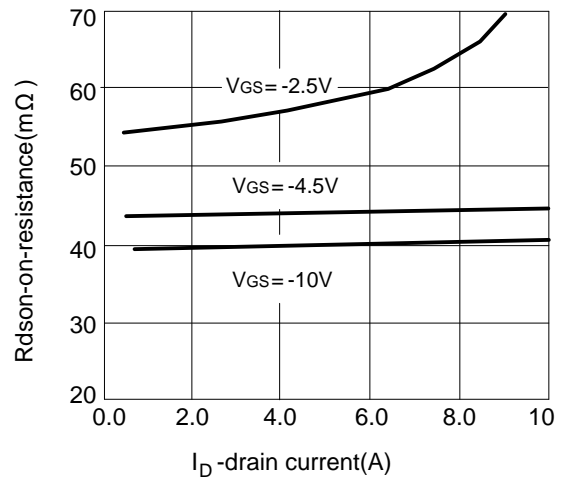

Fig.2 on resistance vs gate to source voltage

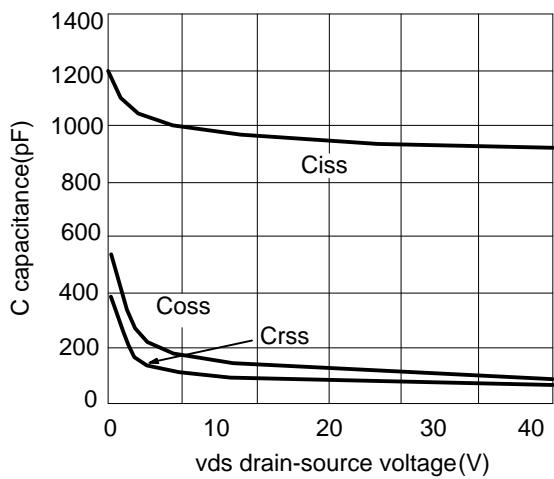

Fig.3 capacitance vs vds

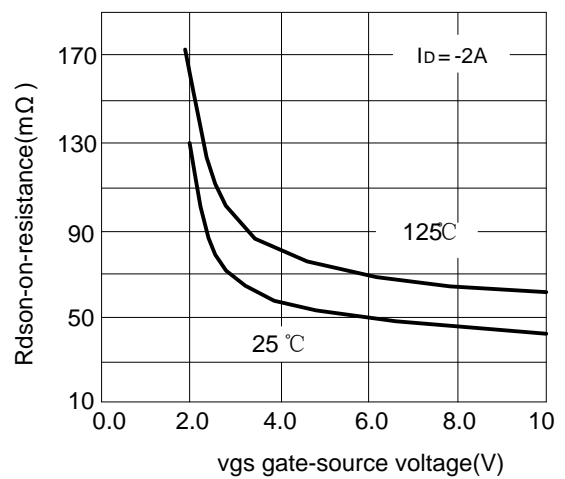

Fig.4 on resistance vs gate to source voltage

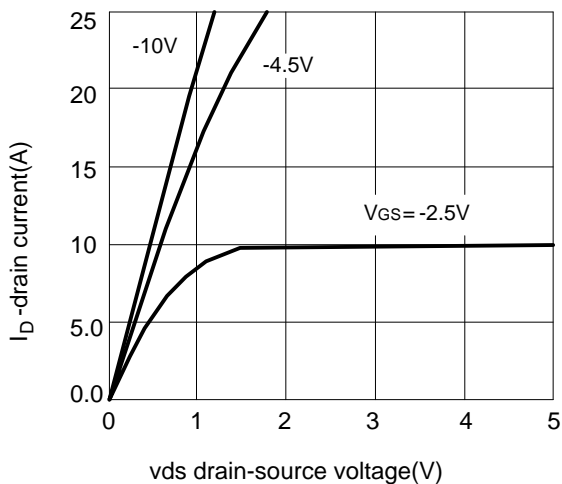

Fig.5 output characteristics

■ SOT-23A-3L PACKAGE OUTLINE DIMENSIONS

