

1. Basic Features

- Short circuit protection
- Current limitation
- Overload protection
- Over voltage protection
- Over temperature protection
- Undervoltage shutdown with auto- restart and hysteresis
- Clamp of negative voltage at output with inductive loads
- Very low standby current
- Reverse battery protection with external resistor
- Green Product (RoHS compliant)
- AEC-Q100 qualified

3. Application

- μ C compatible power switch for 12 V and 24 V DC applications
- All types of resistive, inductive and capacitive loads
- Replaces electromechanical relays, fuses and discrete circuits

2. Description

RM75150 is a Smart High-side Power Switch that guarantees smooth on-off of the power tube under all conditions, while being able to connect to inductive loads and having inductive load fast.

RM75150 integrates multiple protection functions. Overload protection, Current limitation, Short circuit protection, Over temperature protection, Over voltage protection, Clamp of negative voltage at output, Fast deenergizing of inductive loads, Electrostatic discharge (ESD) protection.

4. Product Summary

Overvoltage protection	$V_{bb(AZ)}$	53	V
Operating voltage	$V_{bb(on)}$	6...45	V
On-state resistance(typ.)	R_{on}	150	m Ω
Nominal load current	$I_{L(nom)}$	1.4	A
Short circuit current limit	$I_{L(SCP)}$	3	A

5. Ordering Code

Device	Package Type	Marking	Materials	Package			Package Qty
RM75150SS	SOT-223	RM75150SS	Halogen free	Tape&reel	10 reels/box	30k/box	3000/reel
RM75150ESA	ESOP8L	RM75150ESA	Halogen free	Tape&reel	10 reels/box	40k/box	4000/reel
RM75150ESB	ESOP8L	RM75150ESB	Halogen free	Tape&reel	10 reels/box	40k/box	4000/reel

Table of Contents

1.Basic Features	1
2.Description	1
3.Application	1
4.Product Summary	1
5.Ordering Code	1
6.Pin Configuration	3
7.Block Diagram	5
8.Absolute Maximum Ratings	6
9.Electrical Characteristics	7
10.Timing diagrams	9
11.General Product Characteristics	13
12.Functions	16
13.Application Information	18
14.Package	19
15.Recommended Soldering Footprint	21
16.Revision History	22

6.Pin Configuration

RM75150SS (SOT-223)

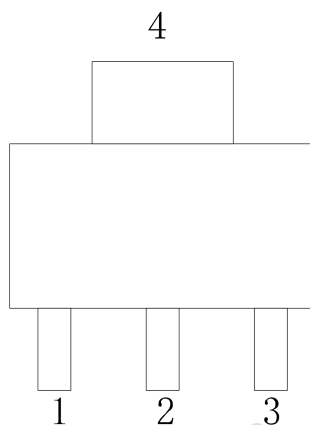

Pin	Symbol	Function
1	OUT	Output to the load
2	GND	Logic ground
3	IN	Input; activates the power switch in case of logic high signal
4	V _{bb}	Positive power supply voltage

RM75150ESA (ESOP8L)

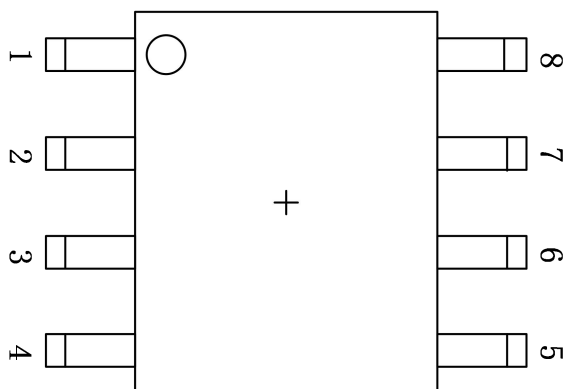

Pin	Symbol	Function
1	GND	Logic ground
2	IN	Input; activates the power switch in case of logic high signal
3/4/5	NC	No internal connection to the chip
6/7/8	OUT	Output to the load
Tab	V _{bb}	Positive power supply voltage

RM75150ESB (ESOP 8L)

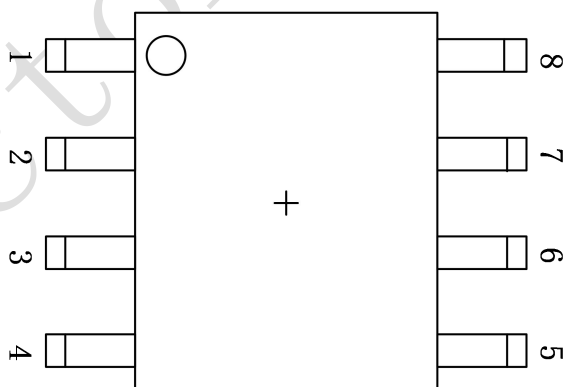

Pin	Symbol	Function
1/2	V _{bb}	Positive power supply voltage
3/6	NC	No internal connection to the chip
4	GND	Logic ground
5	IN	Input; activates the power switch in case of logic high signal
7/8	OUT	Output to the load

7. Block Diagram

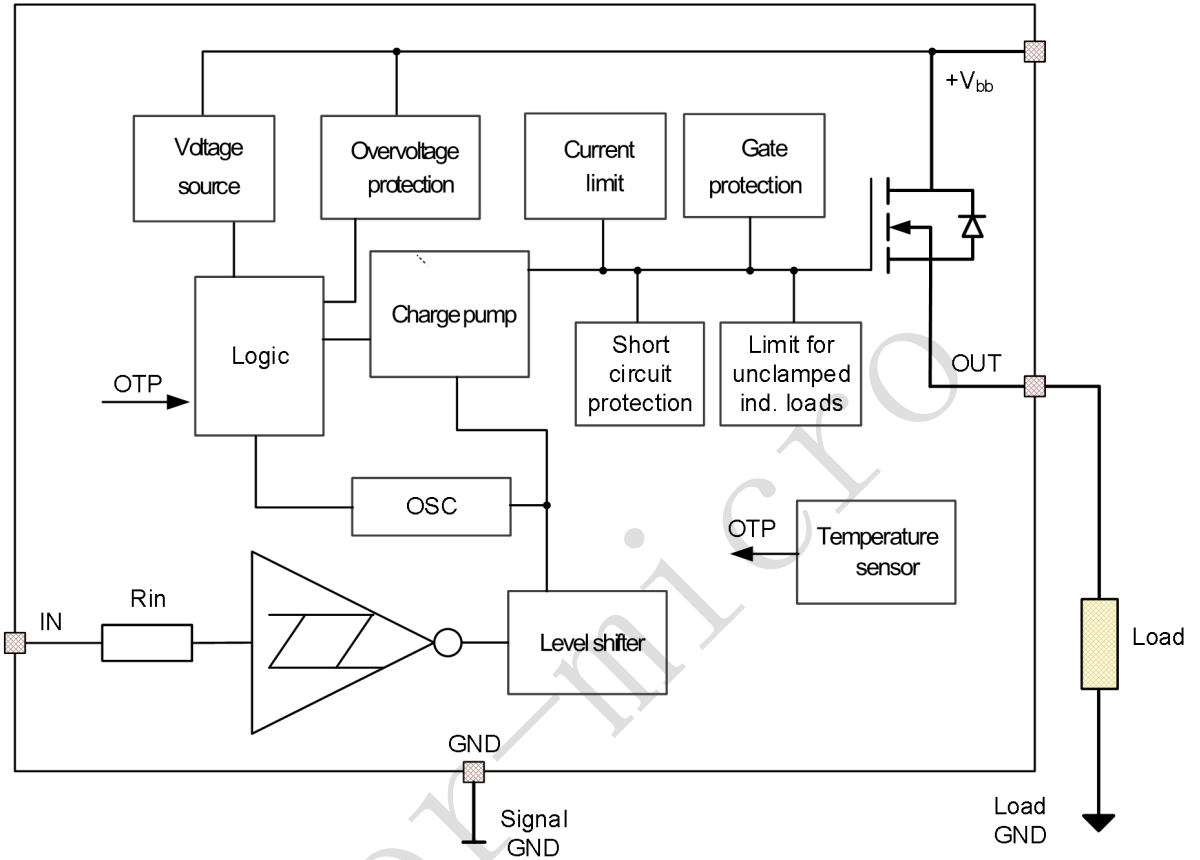

8. Absolute Maximum Ratings¹⁾

(Maximum Ratings at T_j = 25 °C unless otherwise specified)

Parameter	Symbol	Values	Unit	Note or Test Condition
Supply voltage	V _{bb}	45	V	
Load dump protection	V _{Load dump}	83	V	V _{LoadDump} =V _A +V _S , R _I =2Ω, t _d =400ms, V _{IN} =low or high, V _A =13.5V, R _L =47Ω
Current through input pin (DC)	I _{IN}	-5 to 5	mA	
Reverse current through GND-pin	-I _{GND}	-0.5	A	
Power dissipation (DC)	P _{tot}	1.1	W	SOT223
Continuous input voltage	V _{IN}	-10...V _{bb}	V	
Operating temperature	T _j	-40 to 150	°C	
Ambient temperature	T _a	-40 to 125	°C	
Storage temperature	T _{stg}	-55 to 150	°C	
Thermal resistance @ 6 cm ² cooling area	R _{TH(JA)}	89.4	W	SOT223

Notes:

- Stresses above the ones listed here may cause permanent damage to the device. Exposure to absolute maximum rating conditions for extended periods may affect device reliability.

9. Electrical Characteristics

($T_j = -40^{\circ}\text{C}$ to $+150^{\circ}\text{C}$ unless otherwise specified)

Symbol	Parameter	Test Condition	Values			Unit
			Min	Typ	Max	
R_{on}	On-state resistance	$V_{bb}=24\text{V}, V_{IN}=5\text{V}, I_{OUT}=0.5\text{A}, T_j=25^{\circ}\text{C}$	-	150	200	m Ω
		$V_{bb}=24\text{V}, V_{IN}=5\text{V}, I_{OUT}=0.5\text{A}, T_j=150^{\circ}\text{C}$	-	270	320	
$I_{L(nom)}$	Nominal load current	$V_{bb}=24\text{V}, V_{IN}=5\text{V}$	1.4	-	-	A
t_{on}	Turn-ON time	V_{IN} Turn-ON time to $V_{OUT} = 90\%V_{bb}$, $R_L=47\Omega, V_{bb}=15\text{V}$	-	57	100	μs
t_{off}	Turn-OFF time	V_{IN} Turn-OFF time to $V_{OUT} = 10\%V_{bb}$, $R_L=47\Omega, V_{bb}=15\text{V}$	-	55	150	μs
dV/dt_{on}	Turn-ON Slew rate	V_{OUT} From $10\%V_{bb}$ to $30\%V_{bb}$, $R_L=47\Omega, V_{bb}=15\text{V}$	-	0.9	2	V/ μs
$-dV/dt_{off}$	Turn-OFF Slew rate	V_{OUT} From $70\%V_{bb}$ to $40\%V_{bb}$, $R_L=47\Omega, V_{bb}=15\text{V}$	0.7	-	-	V/ μs
$V_{bb(on)}$	Operating voltage	$V_{IN}=5\text{V}, R_L=100\Omega$	6.0	-	45	V
$V_{bb(under)}$	Under voltage shutdown	$V_{IN}=5\text{V}, R_L=100\Omega$	4.5	-	5.5	V
$V_{bb(urst)}$	Under voltage restart	$V_{IN}=5\text{V}, R_L=100\Omega$	-	-	5.8	V
$\Delta V_{bb(under)}$	Under voltage hysteresis		-	-	0.5	V
$I_{bb(off)}$	Standby current	$V_{IN}=0, V_{bb}=30\text{V}, T_j \leq 25^{\circ}\text{C}$	-	11	25	μA
I_{GND}	Operating current	$V_{bb}=30\text{V}, V_{IN}=5\text{V}, V_{OUT}$ floating	-	-	1.6	mA
$I_{L(off)}$	Leakage output current	$V_{bb}=15\text{V}, V_{IN}=0\text{V}$	-	-	10	μA
$I_{L(SCP)}$	Initial peak short circuit current limit	$V_{bb}=24\text{V}, V_{IN}=5\text{V}, T_j=25^{\circ}\text{C}$	1.4	3	4.5	A
$V_{ON(CL)}$	Output clamp (inductive load switch off)	$V_{bb}=24\text{V}, V_{IN}=5\text{V}, f=20\text{Hz}, D=10\%$, $R_L=1\text{H}$	62	68	-	V
T_{jt}	Thermal overload trip temperature	$V_{bb}=12\text{V}, V_{IN}=5\text{V}, R_L=18\Omega$	135	-	-	$^{\circ}\text{C}$
ΔT_{jt}	Thermal hysteresis		-	10	-	$^{\circ}\text{C}$
$V_{bb(AZ)}$	Over voltage protection	$V_{IN}=5\text{V}, R_{GND}=330\Omega$	47	53	-	V
$V_{IN(T+)}$	Input turn-on threshold voltage		-	2.5	3	V
$V_{IN(T-)}$	Input turn-off threshold voltage		1.7	2.3	-	V
$V_{IN(T)}$	Input threshold hysteresis		-	-	1.0	V
$I_{IN(on)}$	On state input current	$V_{bb}=15\text{V}, R_L=47\Omega, V_{IN}=3\text{V}$	10	-	110	μA
$I_{IN(off)}$	Off state input current	$V_{bb}=15\text{V}, R_L=47\Omega, V_{IN}=1.7\text{V}$	10	-	110	μA

$t_{d(V_{bbon})}$	Input delay time at switch on V_{bb}	$V_{bb}=15V, V_{IN}=5V, R_L=47\Omega$	150	230	-	us
$-V_{ON}$	Drain-source diode voltage	$V_{bb}=24V, T_j=25^\circ C$	-	-	1.2	V

10. Timing diagrams

Figure 1: V_{bb} turn on

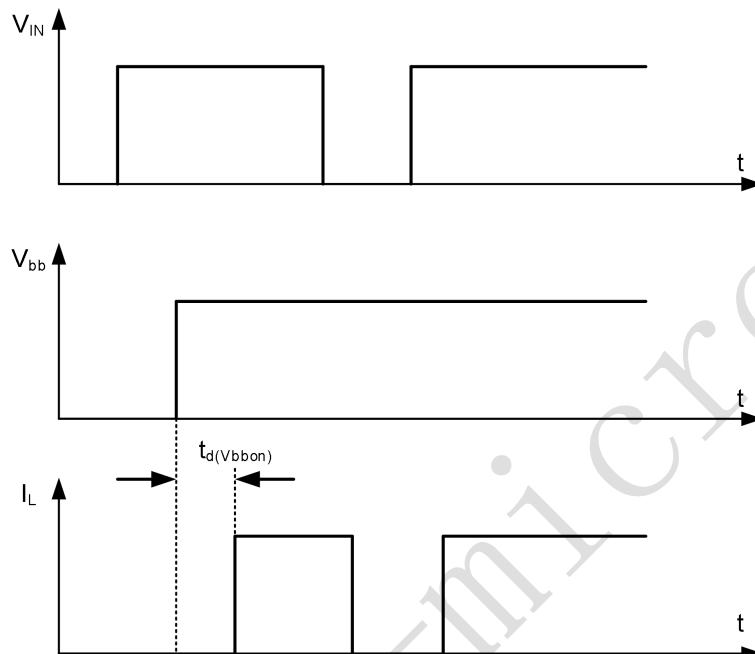

Figure 2a: Switching a resistive load, turn-on/off time and slew rate definition

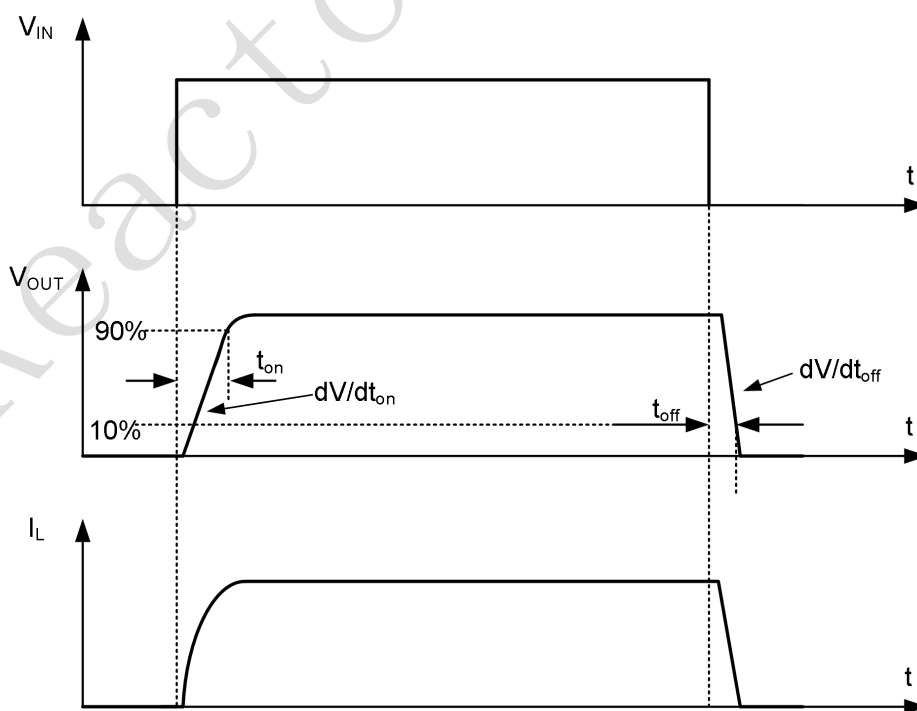

Figure 2b: Switching a lamp

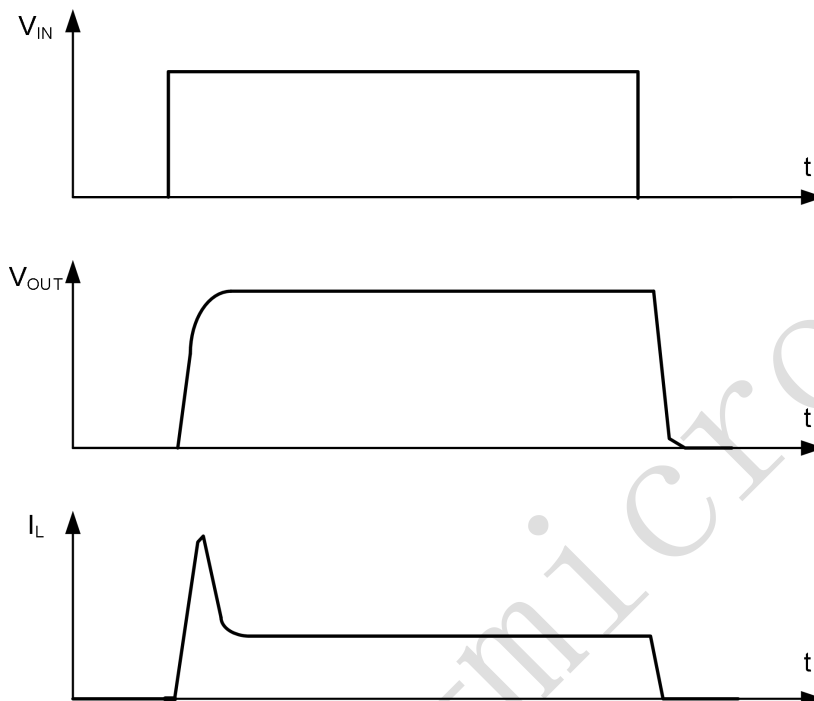

Figure 2c: Switching an inductive load

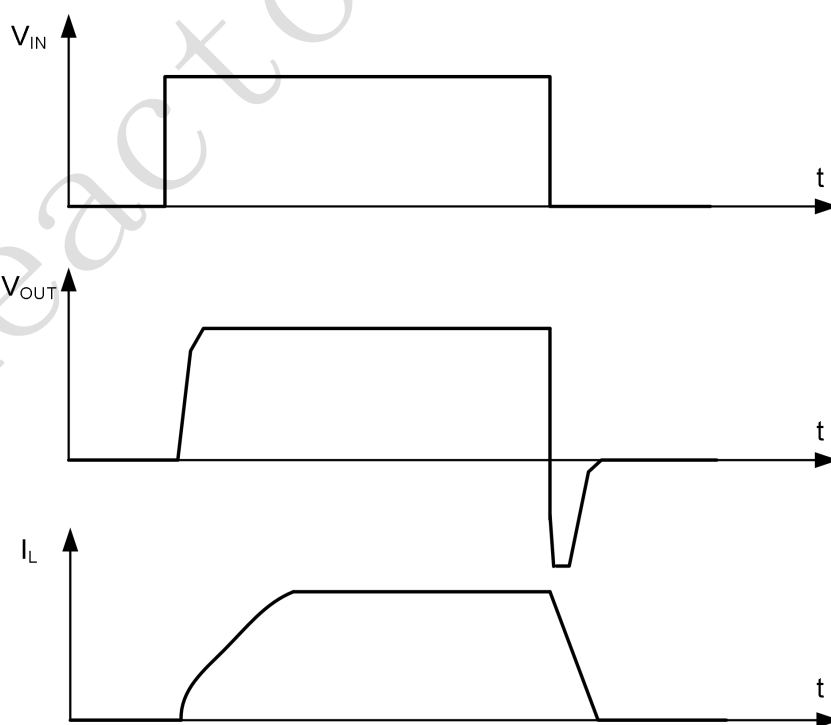

Figure 3a: Turn on into short circuit, shut down by overtemperature, restart by cooling

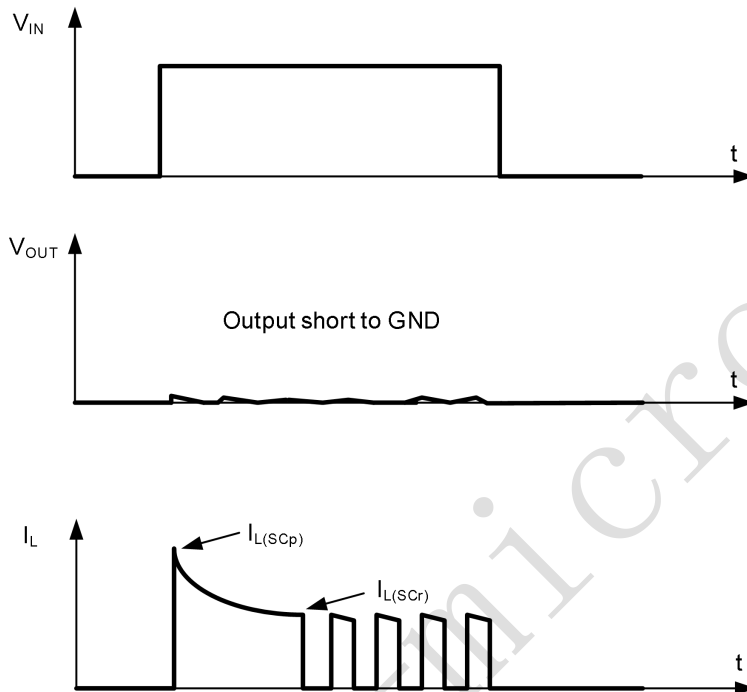

Figure3b: Short circuit in on-state shut down by overtemperature, restart by cooling

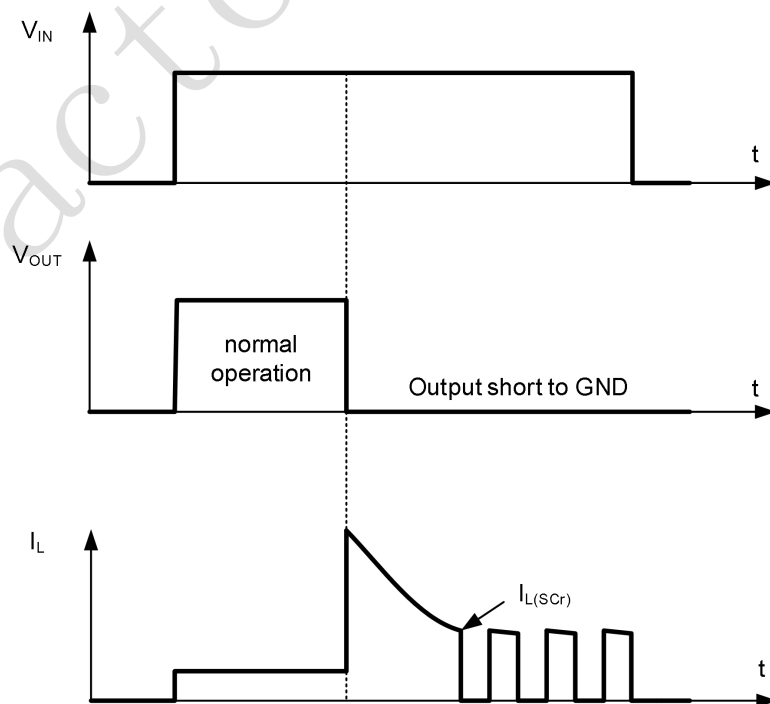

Figure4:Overtemperature: Reset if $T_j < T_{jt}$

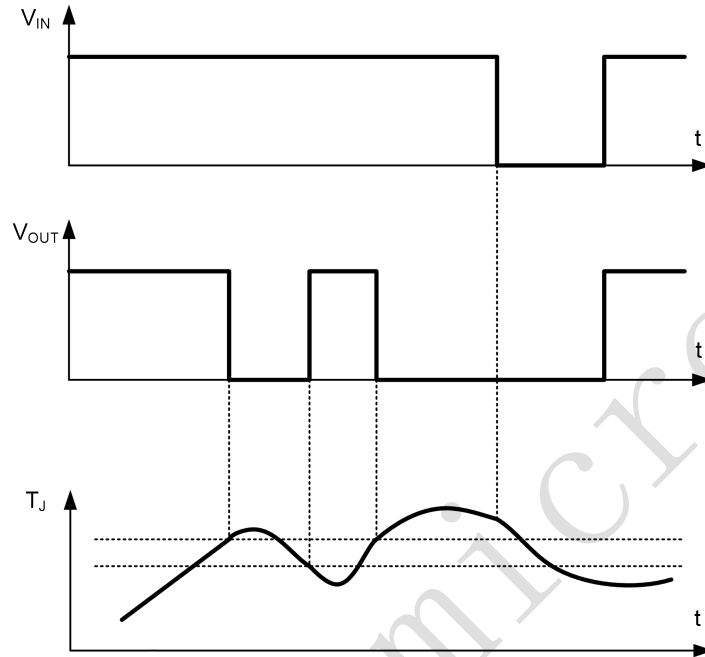
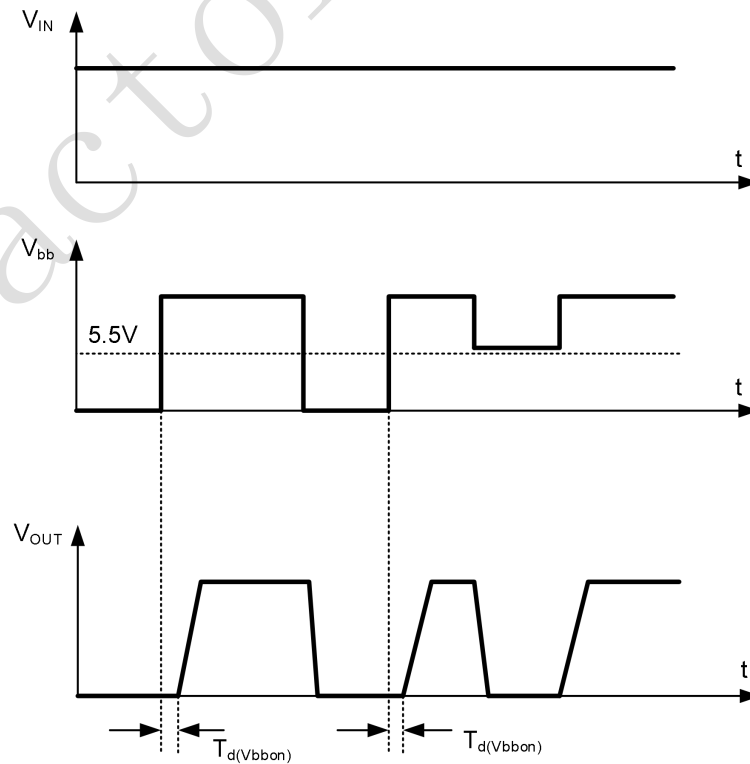
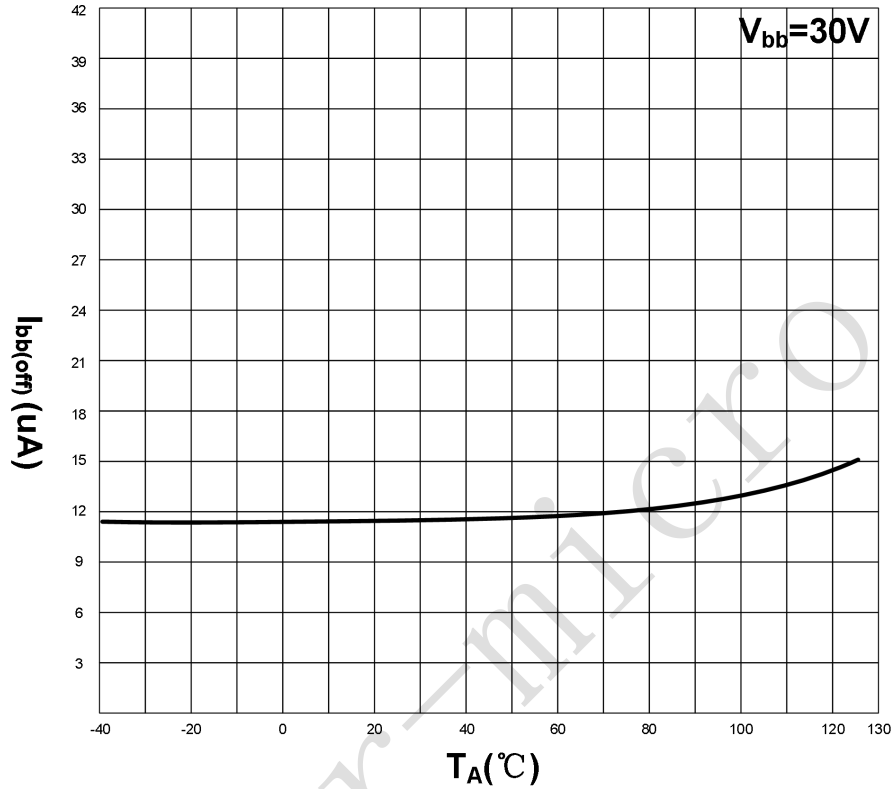

Figure5: Undervoltage shutdown and restart



11. General Product Characteristics

11.1 Standby Current



11.2 Operating current

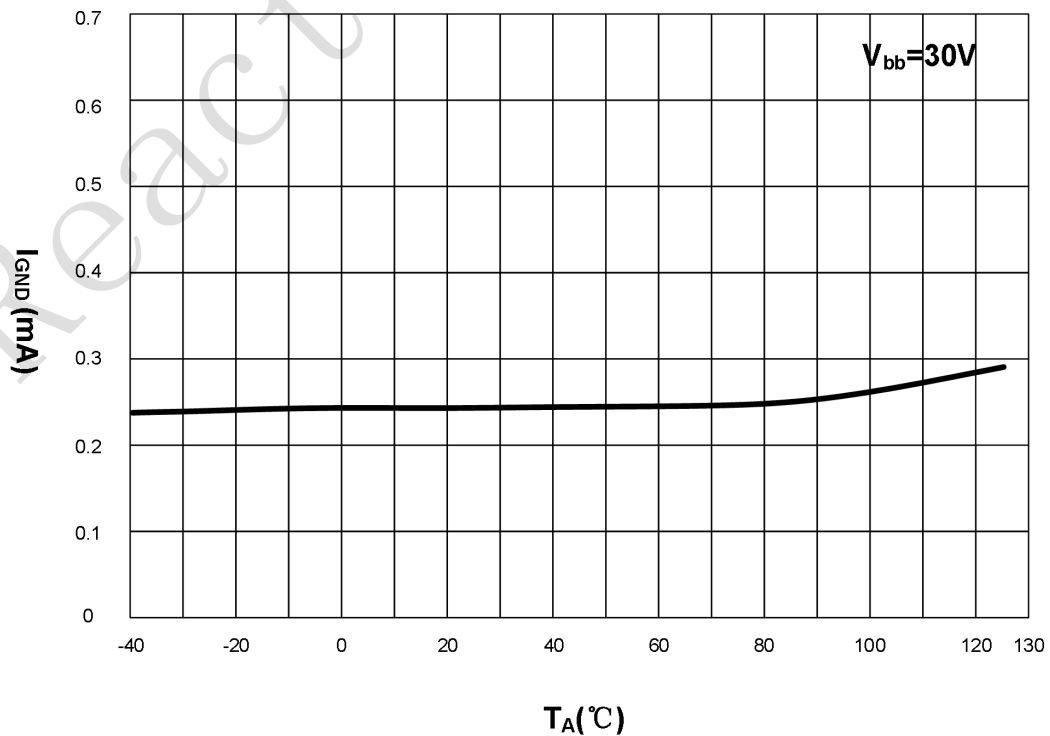

11.3 Leakage output current

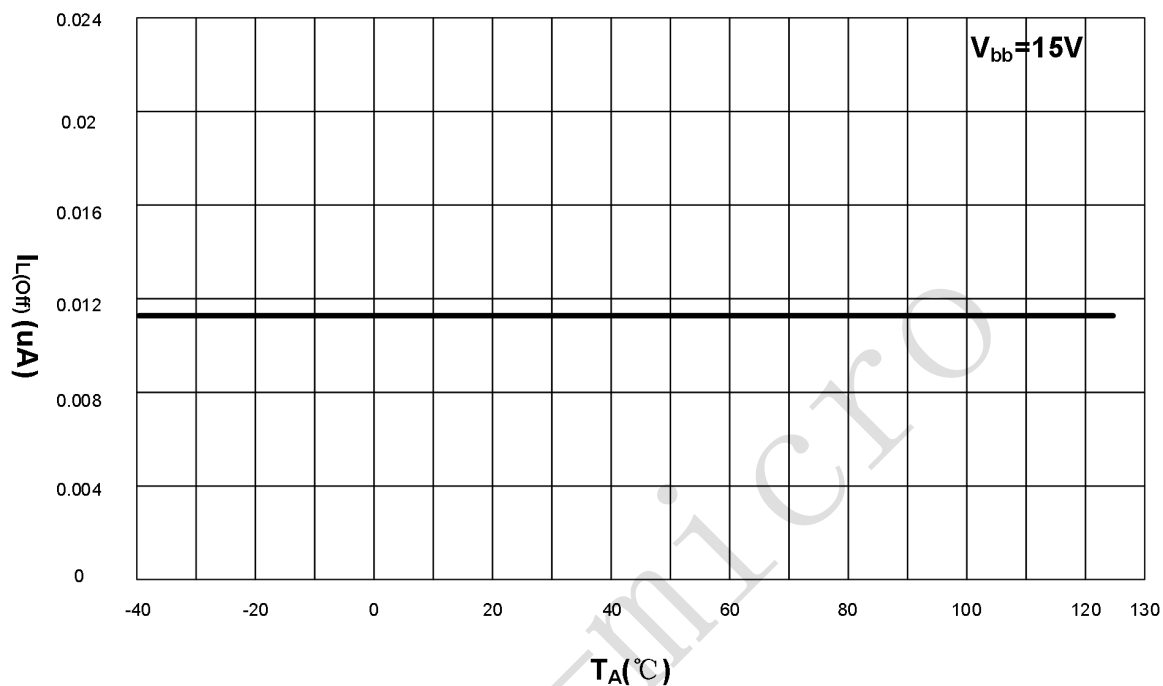

11.4 Drain-source diode voltage

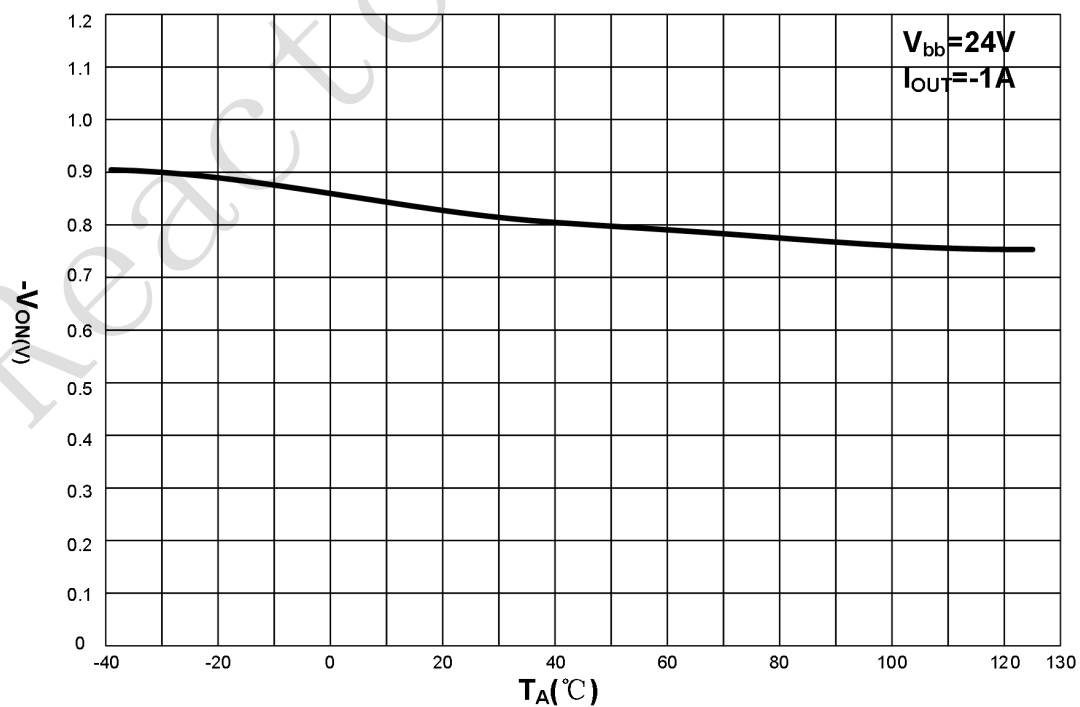

11.5 Typical ON-State Resistance

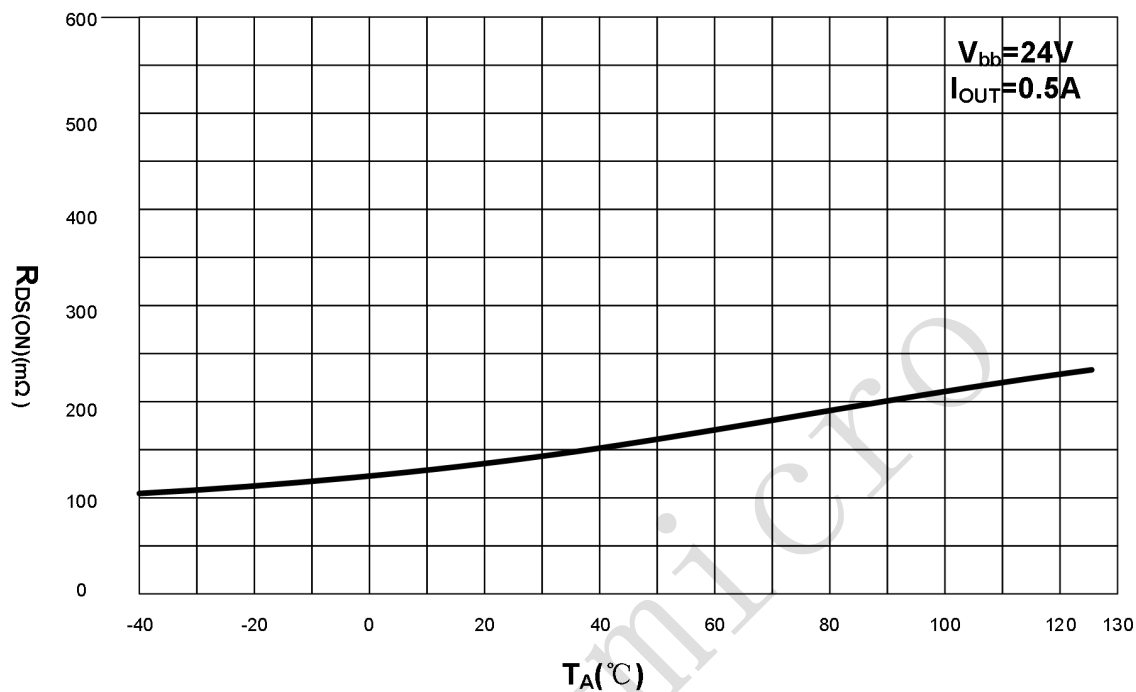

12.Functions

12.1 Terms

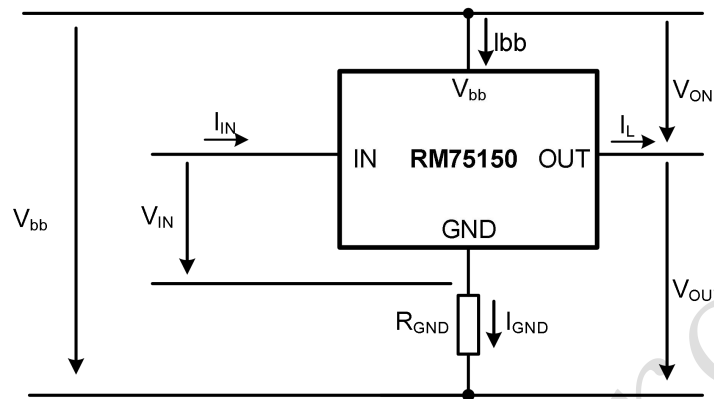

12.2 Input circuit (ESD protection)

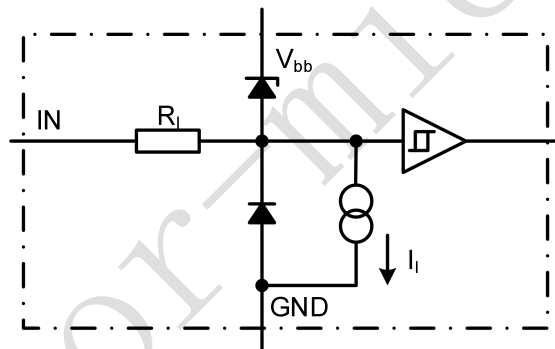

The use of ESD zener diodes as voltage clamp at DC conditions is not recommended

12.3 Reverse battery protection

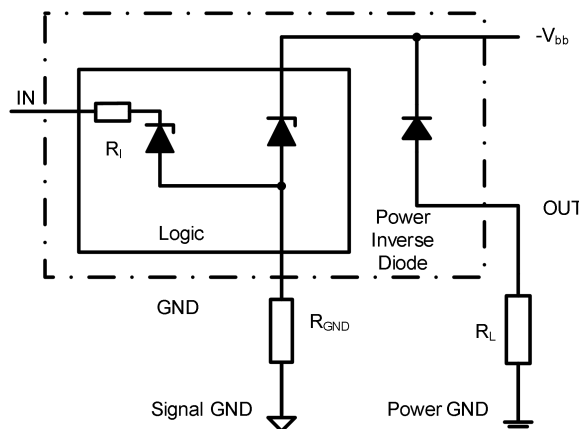

$R_{GND}=330\Omega$, $R_I=3k\Omega$ typ. Temperature protection is not active during inverse current.

12.4 Inductive and overvoltage output clamp

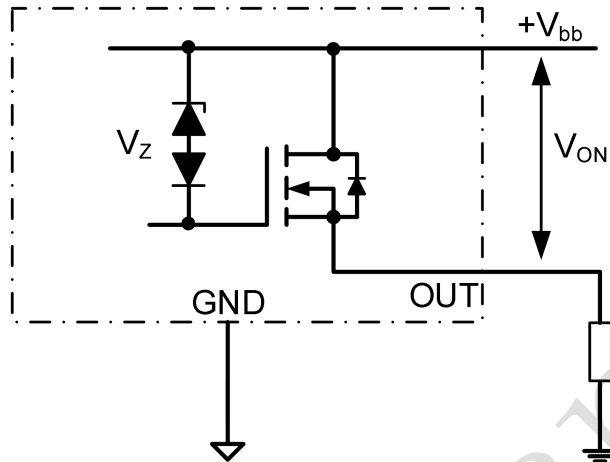

V_{ON} clamped to 62 V min.

12.5 Over voltage protection of logic part

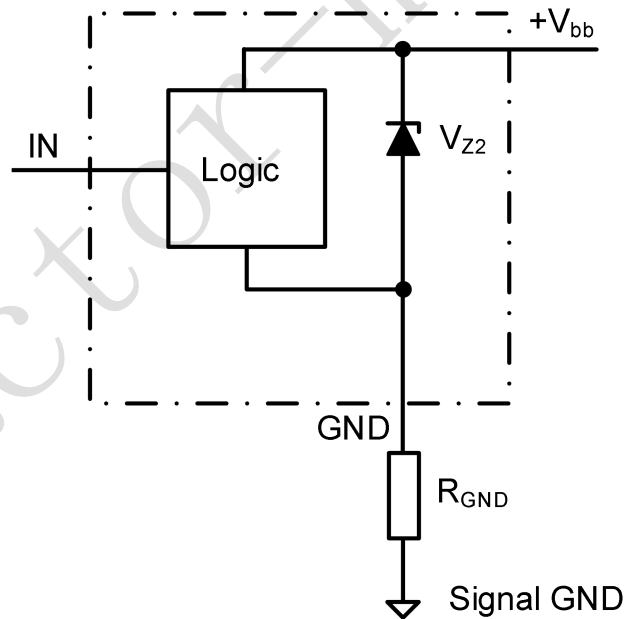

$V_{Z2}=V_{bb(AZ)}=47V$ min., $R_{GND}=330\Omega$

13.Application Information

Note: The following information is given as a hint for the implementation of the device only and shall not be regarded as a description or warranty of a certain functionality, condition or quality of the device.

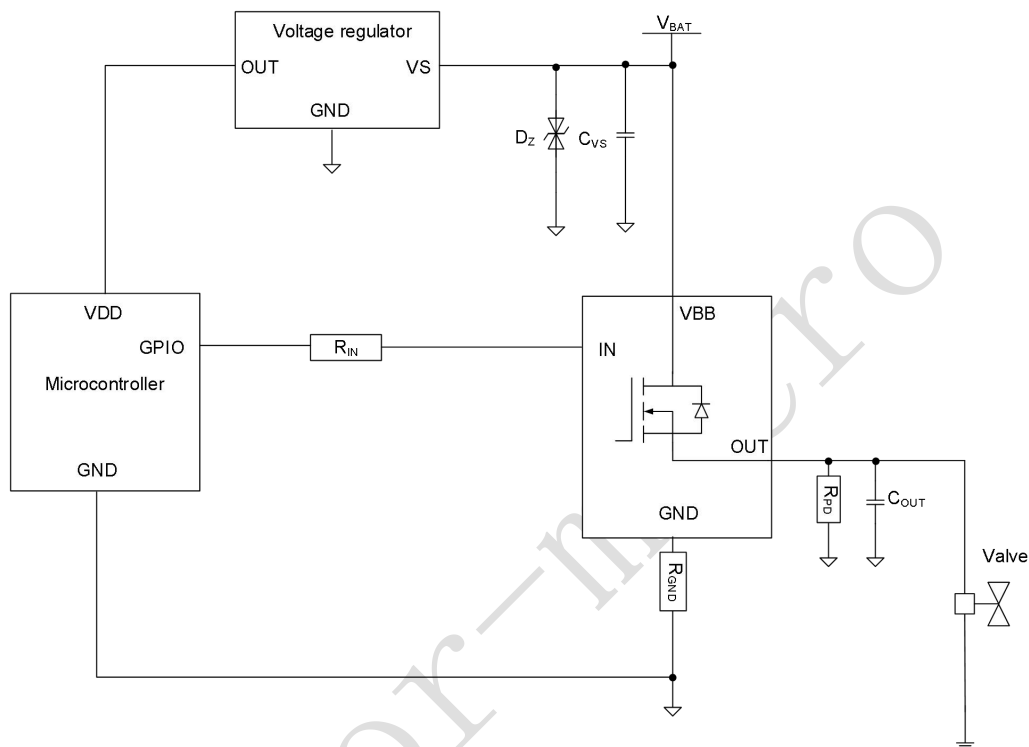

Note: This is a very simplified example of an application circuit. The function must be verified in the real application.

Bill of Material

Reference	Value	Reference	Value
R _{IN}	10kΩ	D _Z	58V Zener diode
R _{GND}	330Ω	C _{VS}	100nF
R _{PD}	47kΩ	C _{OUT}	10nF

14.Package

SOT-223

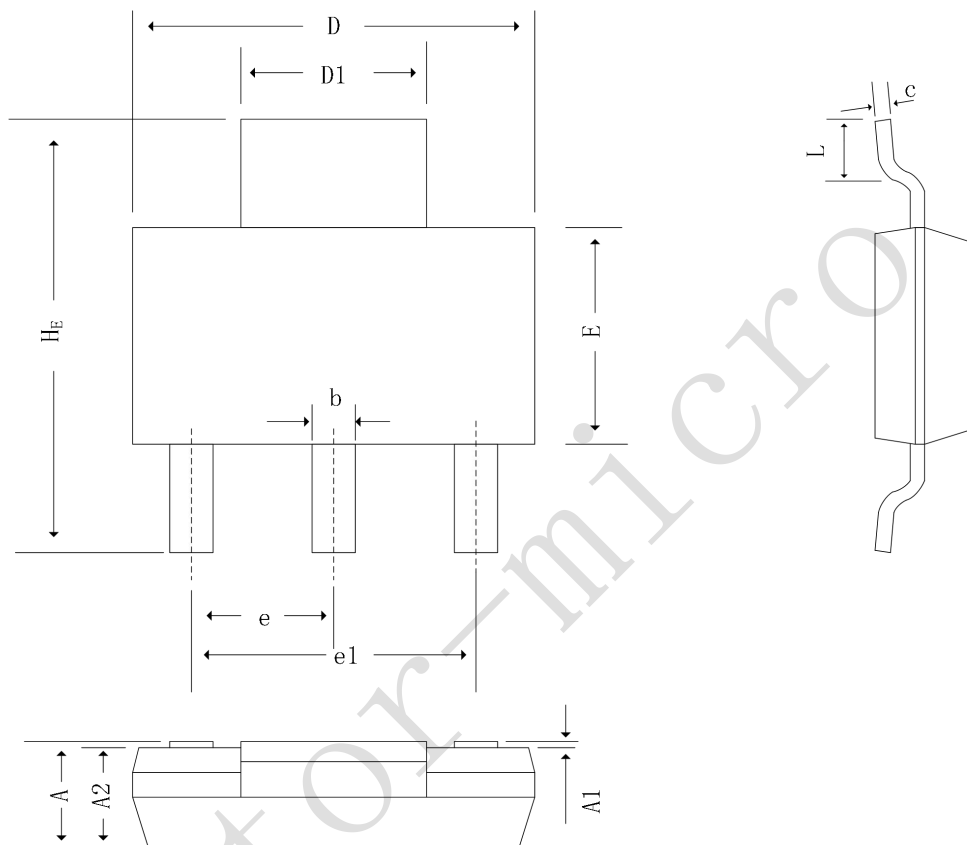

Unit :mm

Symbol	MIN	NOM	MAX
A	/	/	1.80
A1	0.02	/	0.10
A2	1.50	1.60	1.70
b	0.66	0.71	0.84
c	0.23	0.30	0.35
D	6.30	6.50	6.70
D1	2.90	3.00	3.10
E	3.30	3.50	3.70
H _E	6.70	7.00	7.30
e	2.300(BSC)		
e1	4.600(BSC)		
L	0.750	/	/

ESOP8L

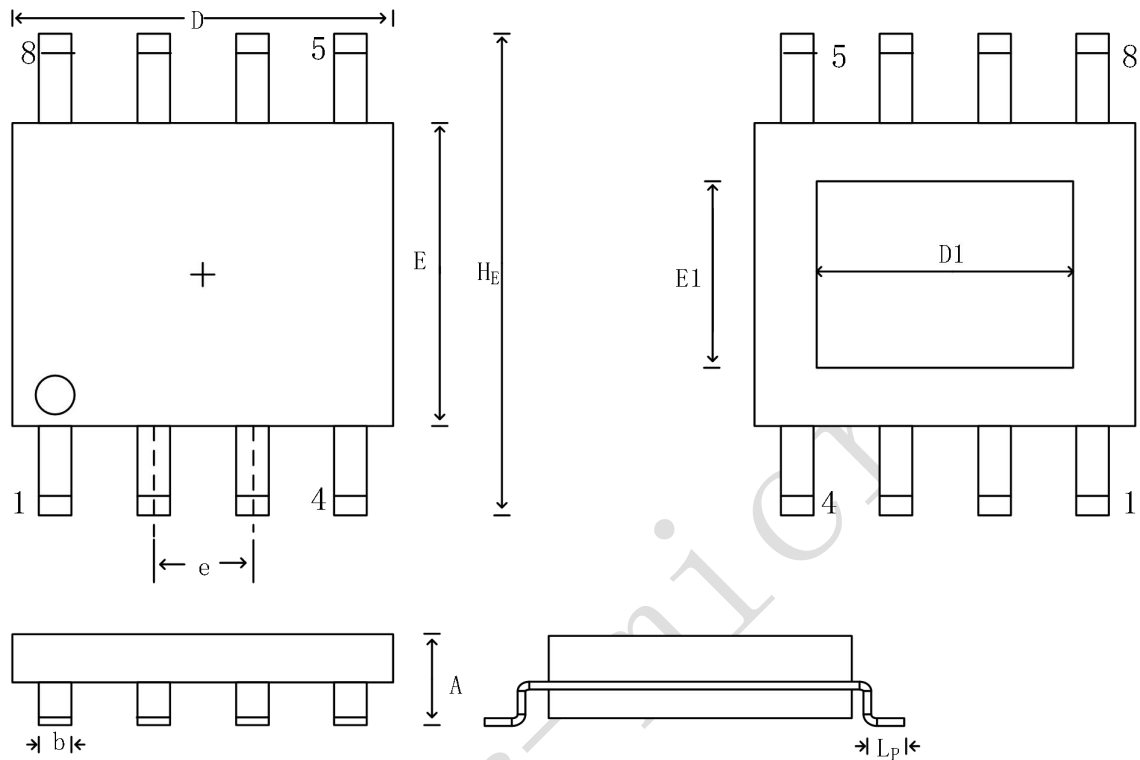

Unit :mm

Symbol	MIN	NOM	MAX
D	4.70	4.90	5.10
E	3.70	3.90	4.10
H_E	6.00	6.20	6.40
e	1.27BSC		
D_1	3.10	3.30	3.50
E_1	2.20	2.40	2.60
A	1.35	1.55	1.75
b	0.35	0.42	0.49
L_P	0.40	0.825	1.25

16.Revision History

Version	Change Description	Date
1.0	Initial Version	2024/08/13
1.1	1) Revised certain parameter names and test conditions in the Electrical Characteristics table. 2) Revised Application Information. 3) Added certain parameter in the Absolute Maximum Ratings 4) Revised and Added certain parameter in the Electrical Characteristics table.	2025/10/09
NOTE*:Datasheets with alphabetic version numbers (e.g., REV.A, REV.B, REV.C) are designated for the sample phase,whereas those with numeric version numbers (e.g., V1.0, V1.1, V1.2) are intended for the mass production phase.		